



 JURALCO

JURALCO 4200 SERIES WARDROBE AND DOOR SYSTEM

ISSUE 8/17

Juralco 4200 Series Wardrobe and Door Systems

Juralco Aluminium Building Products Ltd designs and distributes specialist aluminium joinery systems through a national network of franchised fabricators and agents.

For more than 25 years we have been at the forefront of specialist aluminium door and window products suitable for New Zealand joinery and building methods. Our comprehensive product range includes security and insect screens, balustrades and gates, shutters and awnings, shower screens, wardrobe doors and organisers and internal doors.

The 4200 Series is a modern, compact, bottom rolling wardrobe and internal door system designed to maximise access to storage space especially where triple door applications are preferred. Meltica or Seratone infill can be combined with mid rails to produce modern, attractive door panels. Traditional infill such as painted Gib-Board or safety Mirror can be used to blend with room décor. Doors frames can be custom-made in a variety of powder-coat or anodised colours.

This Guide is intended for use by Architects, Specifiers and Fabricators
Pages 2-3 cover areas of general interest. Pages 4 onwards are intended for Fabricators

Shown below are some typical 4200 system Door solutions for this family house .

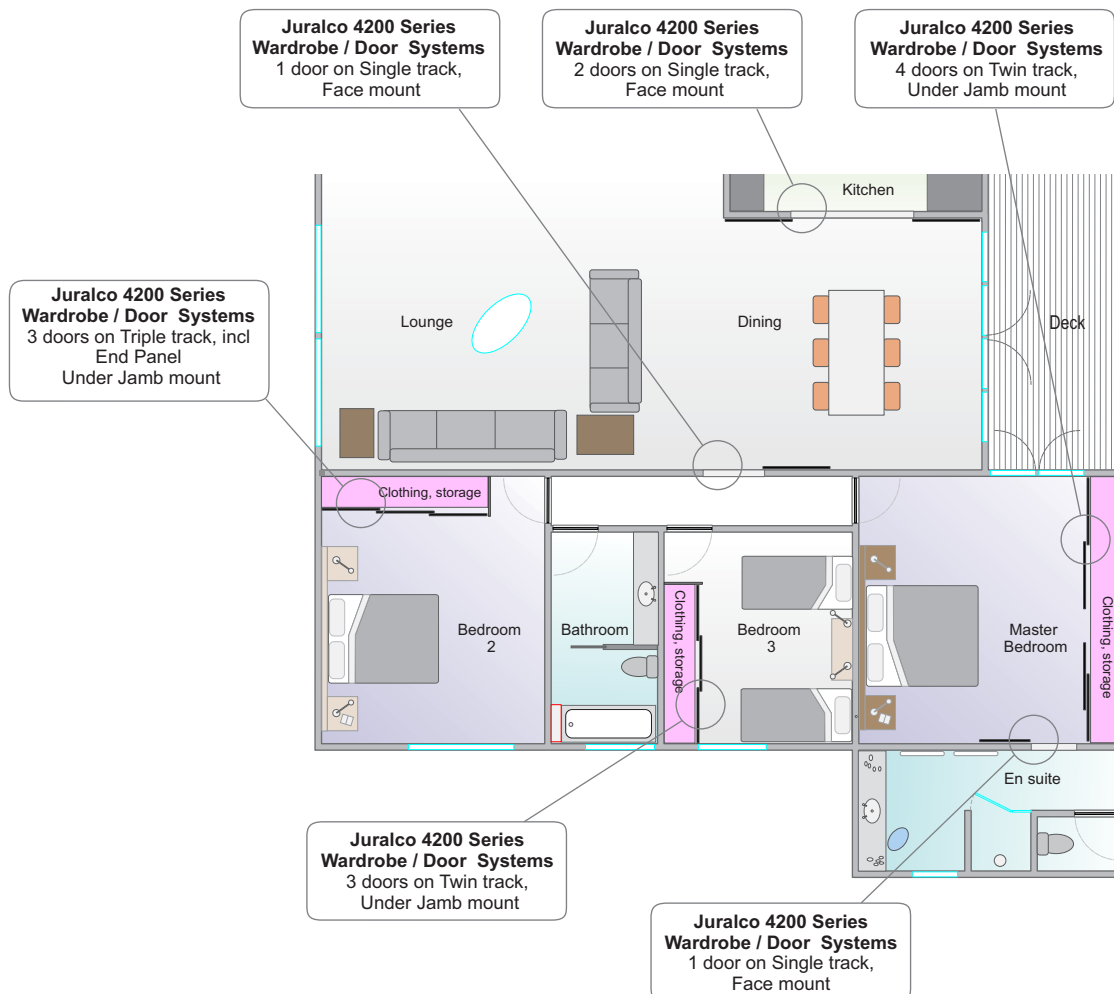

All pages © Copyright Juralco Aluminium Building Products Ltd, 2017

Juralco 4200 Wardrobe and Door Systems - Typical Layouts

One Panel on Single Track
(Face Mount)

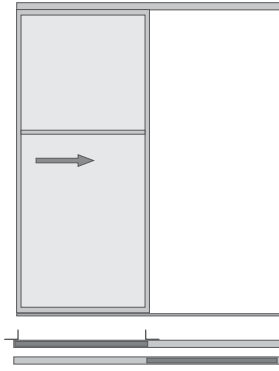

For openings up to
about 1100mm wide
- gives 100% max opening

Two Panels on Single Track
(Face mount)

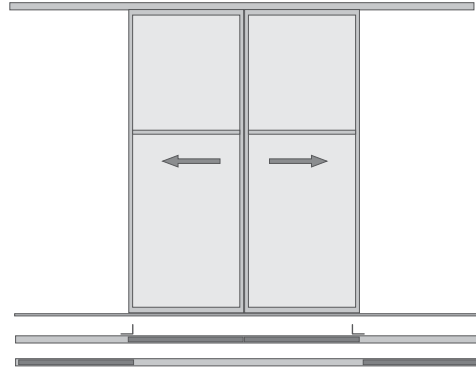

For openings up to
about 2300mm wide
- gives 100% max opening

Two Panels on Twin Track
(between Jamb mount)

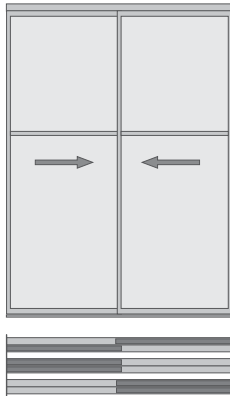

For openings up to
about 2300mm wide
- gives 50% max opening

Four Panels on Twin Track
(between Jamb mount)



For openings up to
about 4700mm wide
- gives 50% max opening

General Description

- Door Panels max overall height (4215 stile) 2400mm, (4212 Heavy Duty Stile) 2700mm, max overall width 1200mm
- Top Track Install - normally Reveal mounted.
Single Track may be Face mounted.
- Bottom Track installs direct to Floor on a Packer.
- Aluminium Extrusions - A range of standard and custom powder-coat and anodised finishes .Contact Juralco.
- Compact Tracking System Single, Double & Triple Tracks.
Triple Track fits within a 90mm Jamb.
- Infill Panels - Panel board, Mirror and Gib infills up to 10mm in thickness. Grooved Aluminium Panel.
- Mid rails - 30mm Flush and 30mm Negative detail Mid Rails available.
- Handles - incorporated in stile extrusion.
- Stile Infill Buffer - Wide range of colour co-ordinated colours.
- Adjustable Bottom Rollers - Concealed Convex Nylon Rollers.
- Weight - up to 50kg Per Panel.
- Quiet Smooth Operation.

Important Note: to conform to NZS4223.3.2016 regulations vinyl backed safety mirror must have a minimum thickness of 4mm with a maximum fully framed area of 2.0m². If the wardrobe system is used as a partition between rooms annealed glass can be used with a minimum thickness of 5mm and maximum area of 0.5m² per panel

Three Panels on Triple Track
(between Jamb mount)



For openings up to
about 3500mm wide
- gives 66% max opening

Juralco 4200 Wardrobe and Door Systems - Extrusions

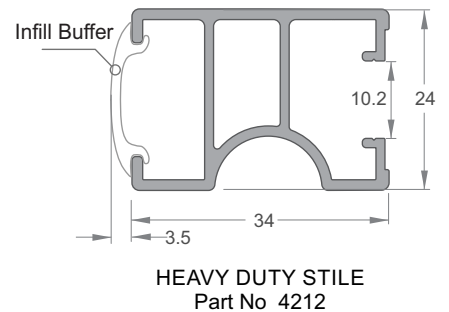
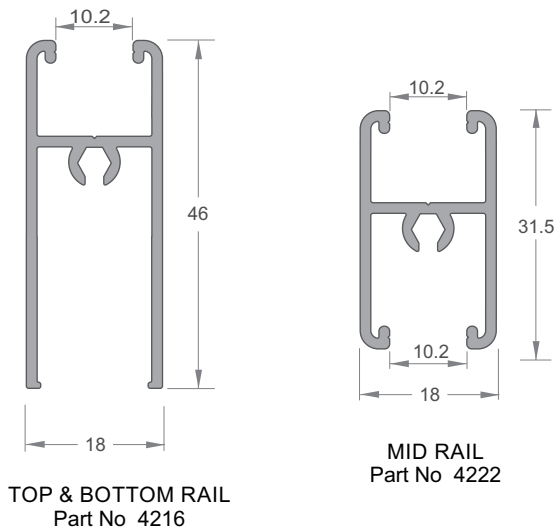
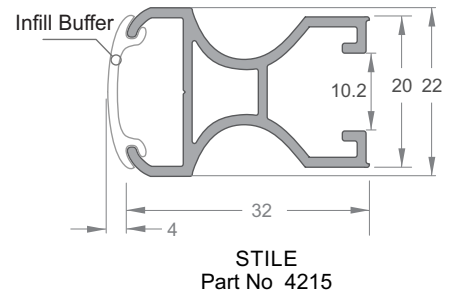
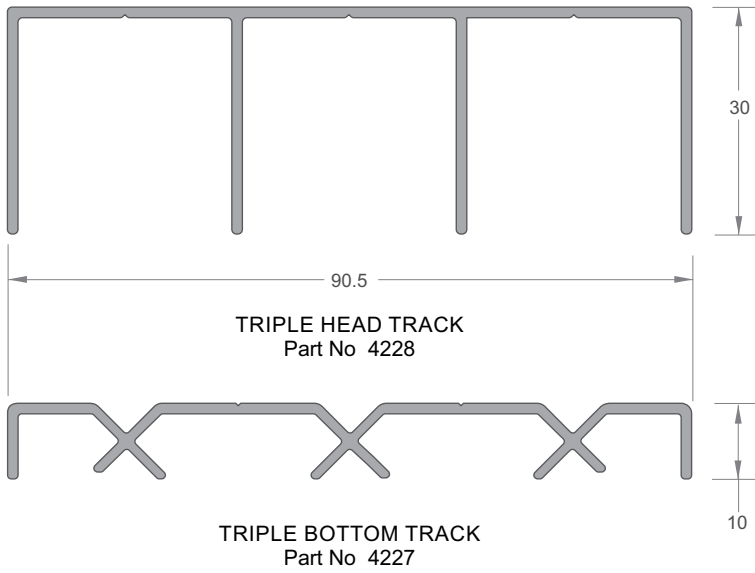
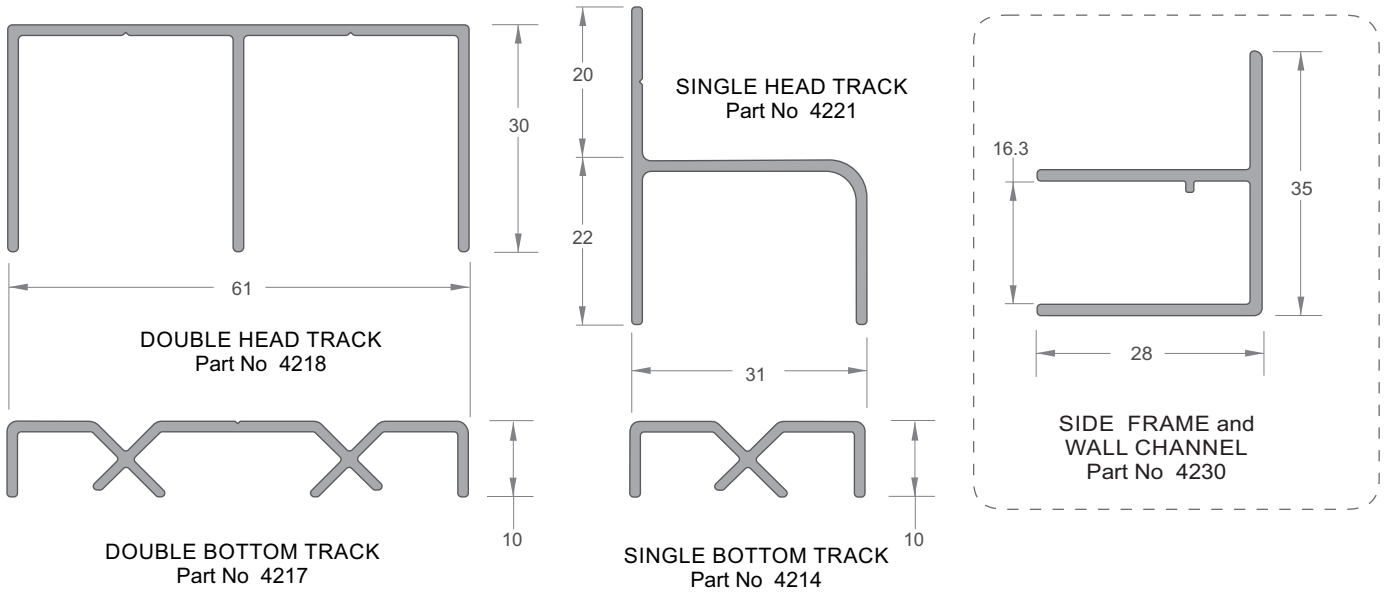

Juralco 4200 Wardrobe and Door Systems - Components

Glass Gasket 4mm
Part No D04

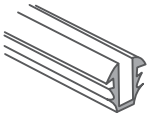

1mm Glazing Wedge
Part No D13



Glazing Wedges
4mm Orange, 5.5mm Green

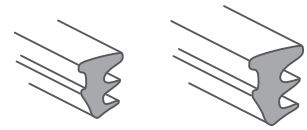

Head Channel Spacer
Part No D14

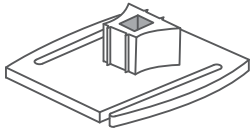

Infill Buffer
Part No D02

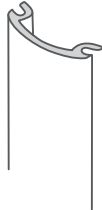

Door Stop
Part No W09

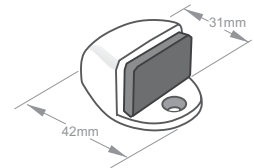

For Single Track

Fastener No 8 x 35
Pan Head

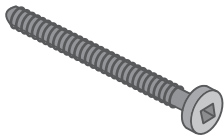

Wardrobe Door Wheel
Part No D15

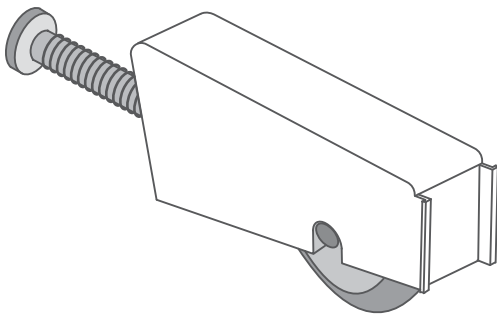

Juralco 4200 Wardrobe and Door Systems - Typical Sections and Features

Typical Vertical Sections

Stile 4215 for Doors up to 2400mm high, Heavy Duty Stile 42123 for Doors up to 2700mm high

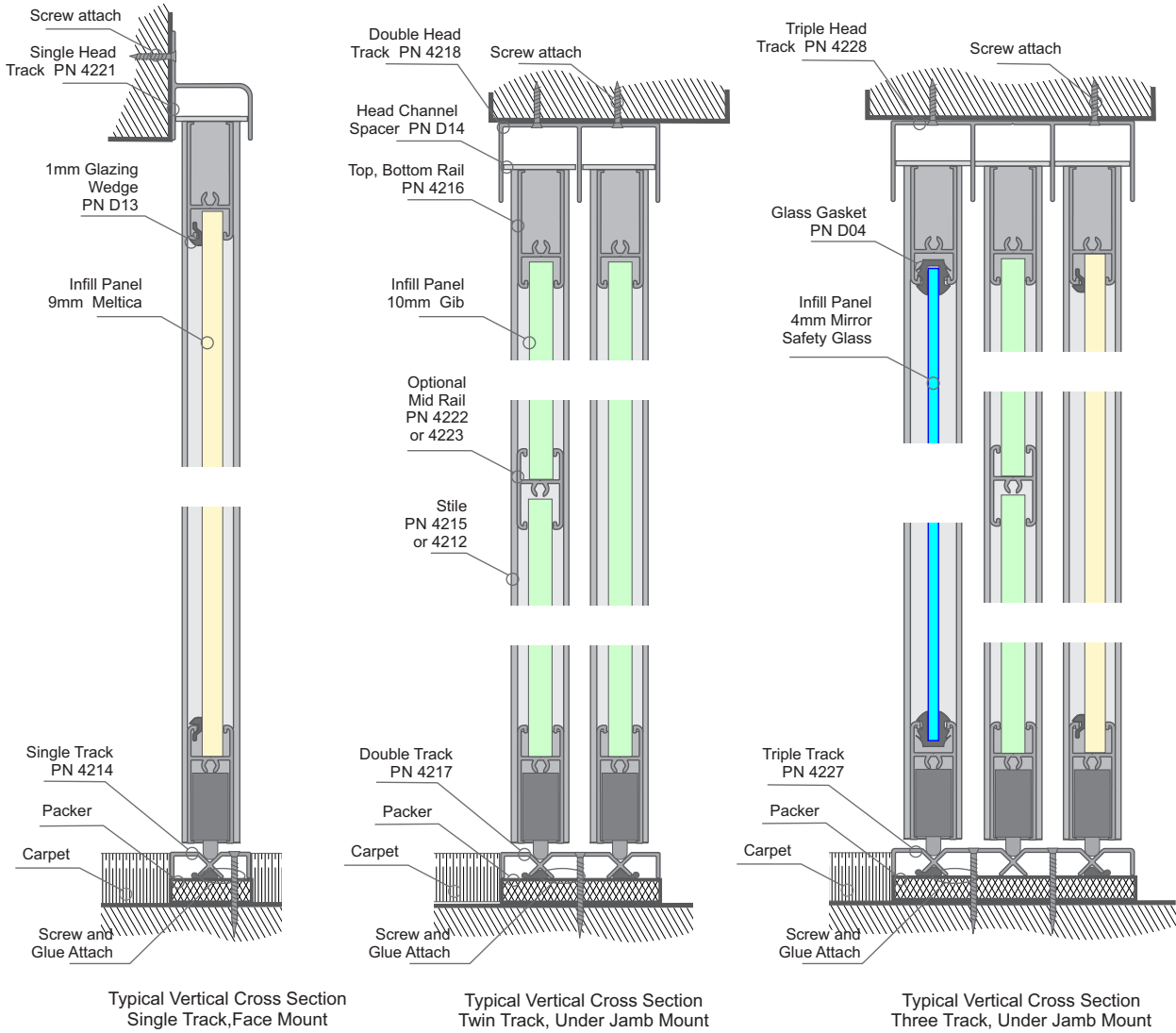

Typical Horizontal Sections

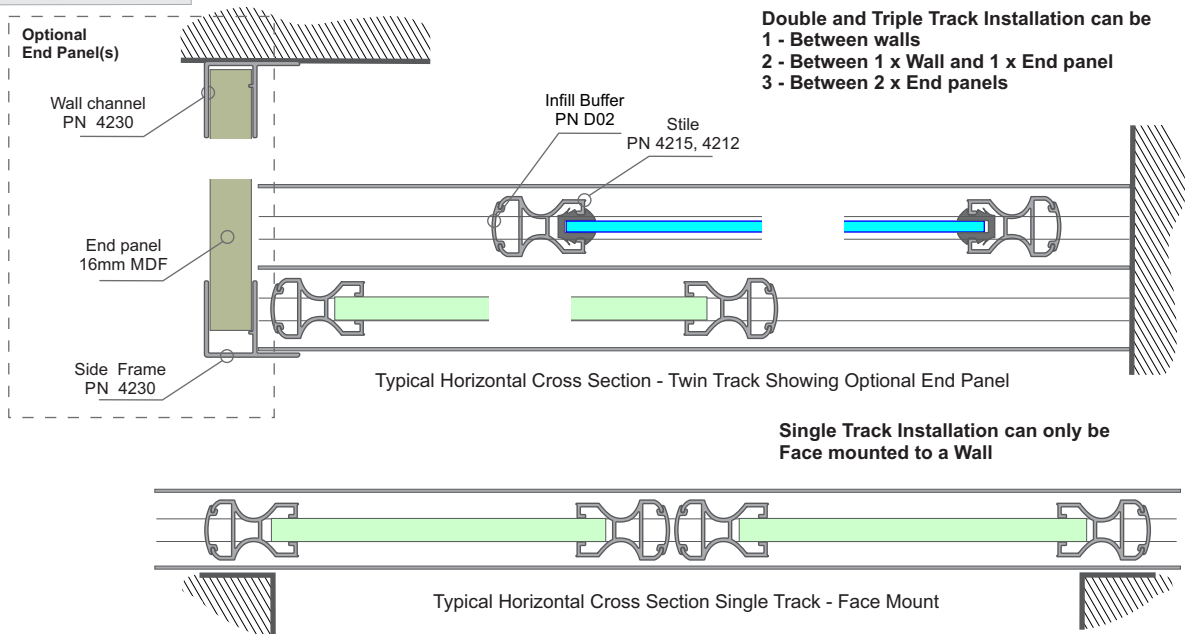

Juralco 4200 Wardrobe and Door Systems - Cutting and Infill Allowances

Vertical Infill Cutting Allowances

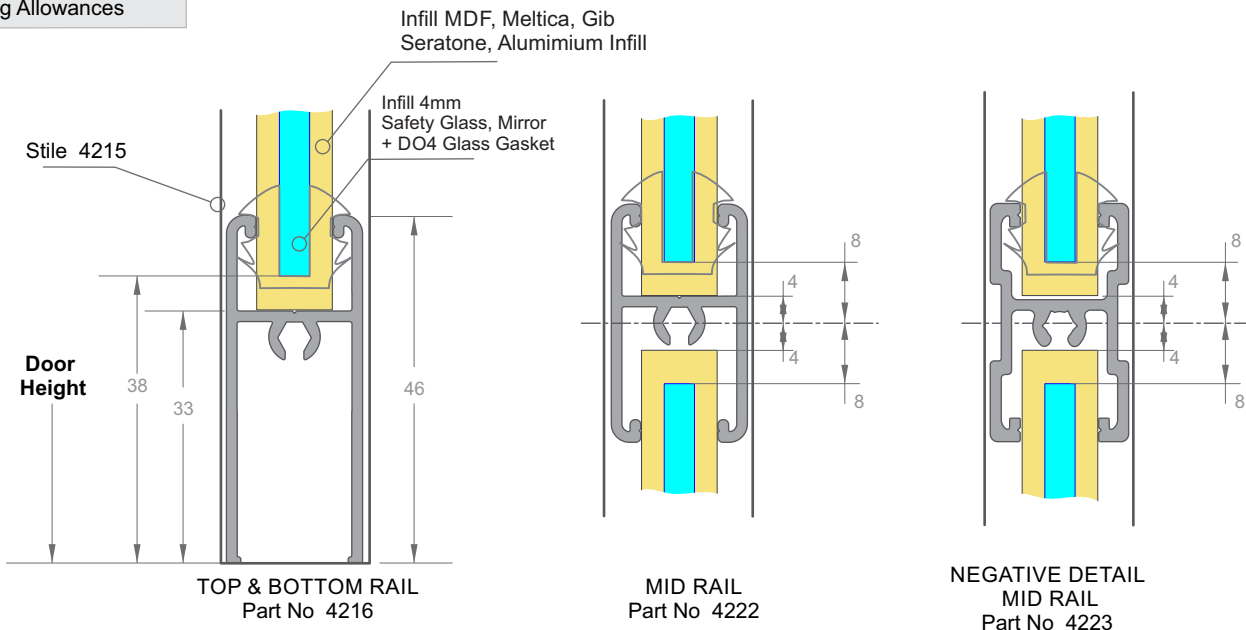

Horizontal Infill Cutting Allowances

Stile 4215 for Doors up to 2400mm high, Heavy Duty Stile 4212 for Doors up to 2700mm high

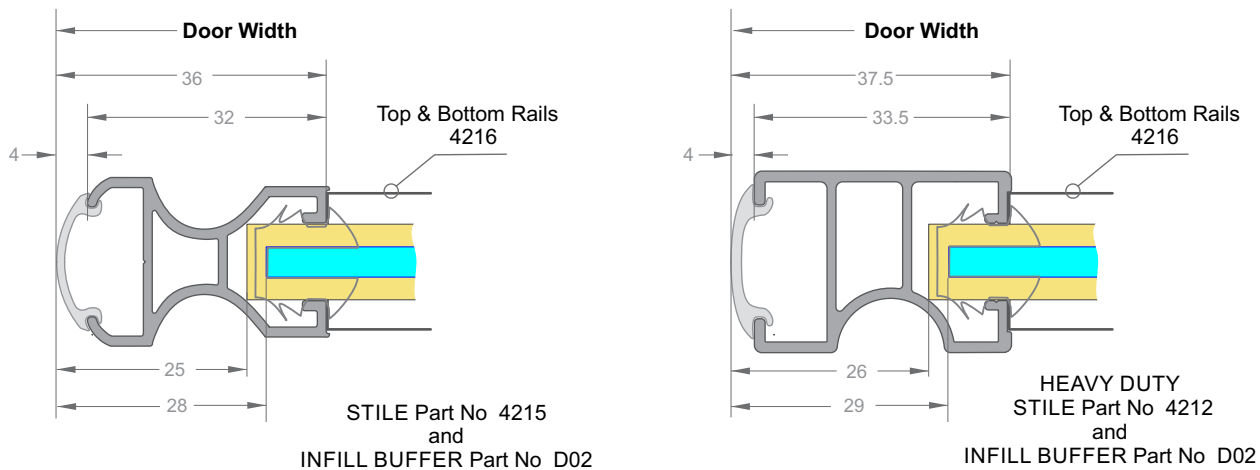

Stile and Infill Buffer Overlaps

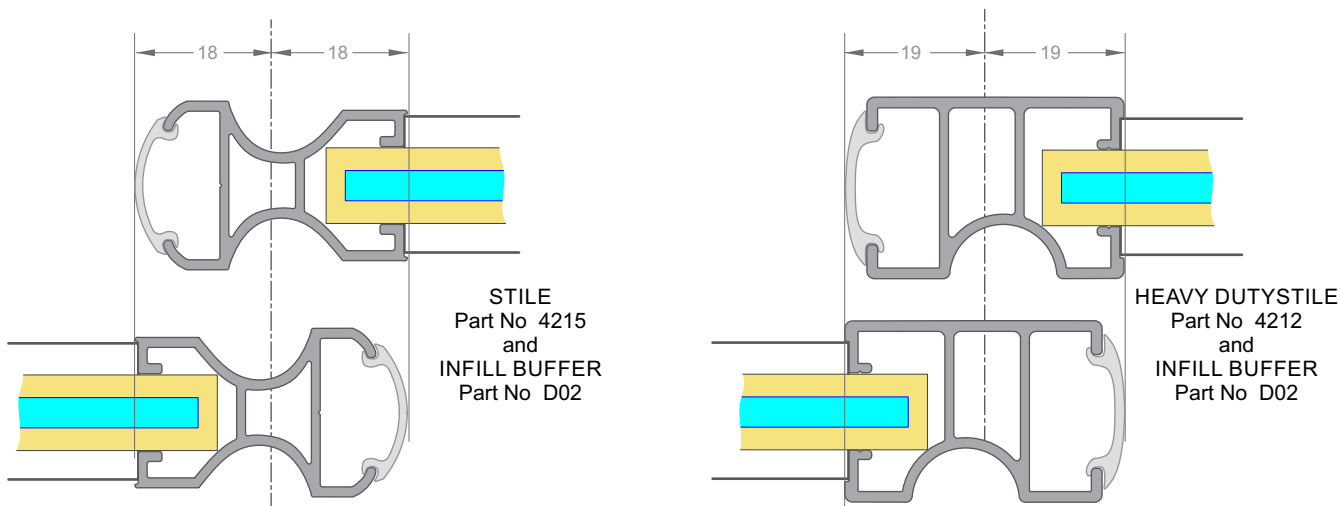

Juralco 4200 Wardrobe and Door Systems - Cutting

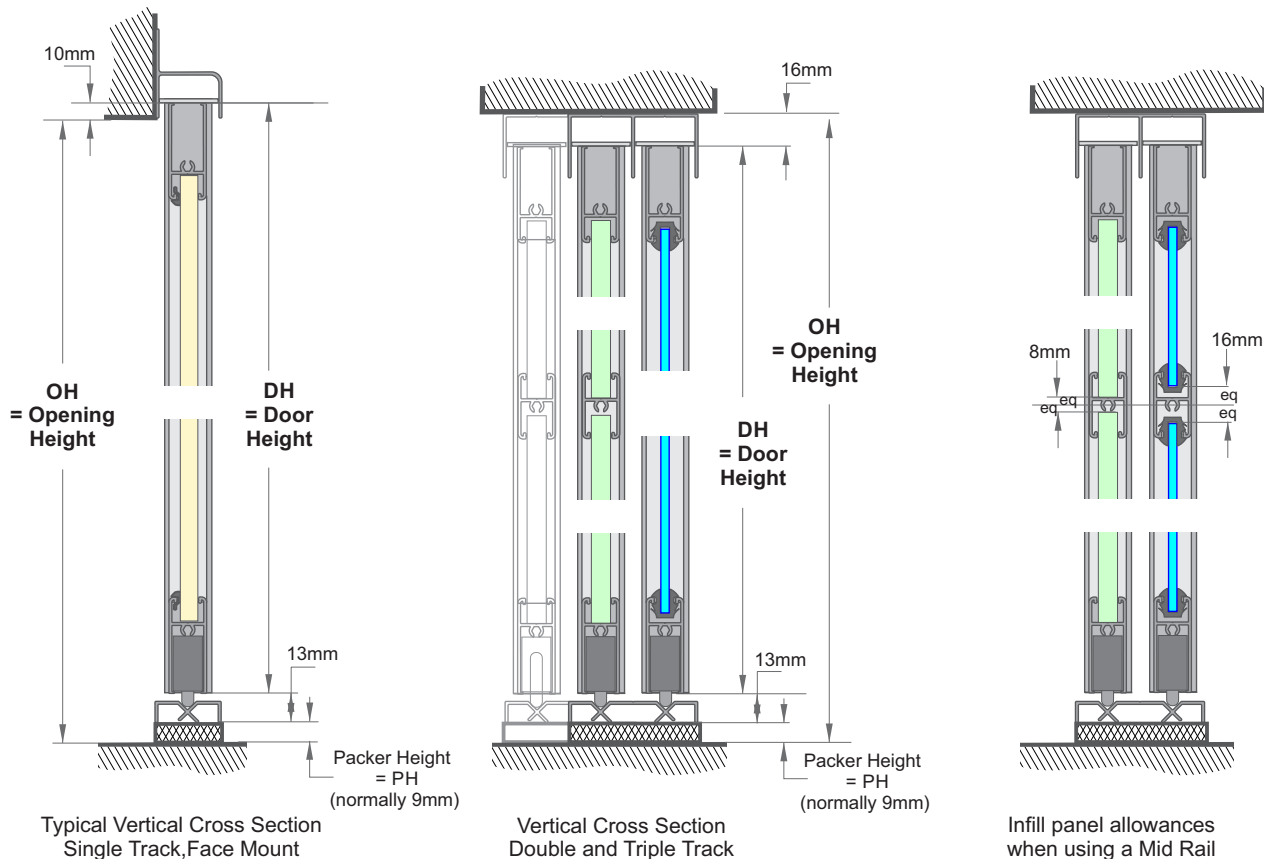

Stile 4215 for Doors up to 2400mm high, Heavy Duty Stile 4212 for Doors up to 2700mm high

ALL DOORS - HEIGHT CUTTING FORMULA

ALL HEIGHTS			
DOOR HEIGHTS - FACE MOUNT		Part	Form ula in m m
1	Single Door, Overall Height = DH		OH - PH - 3 (= DH)

STILE, INFILL HEIGHTS			
1	Door, Stiles. Normal or Heavy Duty	4215, 4212	DH
2	Door, Infill Buffer	D02	DH
3	Infill, MDF, Melteca, Gib, Grooved Aluminium Panel	NA	DH - 66
4	Glazing Wedges (1mm - D13, Green, Orange)	←	DH - 66
5	Infill, 4mm Mirror, Safety Glass	NA	DH - 76
6	Glass Gasket	D04	DH - 76

DOOR HEIGHTS - UNDER JAMB MOUNT		Part	Form ula in m m
1	Single Door, Overall Height = DH		OH - PH - 29 (= DH)

STILE, INFILL HEIGHTS			
1	Door, Stiles. Normal or Heavy Duty	4215, 4212	DH
2	Door, Infill Buffer	D02	DH
3	Infill, MDF, Melteca, Gib, Grooved Aluminium Panel	NA	DH - 66
4	Glazing Wedges (1mm - D13, Green, Orange)	←	DH - 66
5	Infill, 4mm Mirror, Safety Glass	NA	DH - 76
6	Glass Gasket	D04	DH - 76

Note : Mirror, Glass panel size imitations . Refer to page 3

Juralco 4200 Wardrobe and Door Systems - Cutting

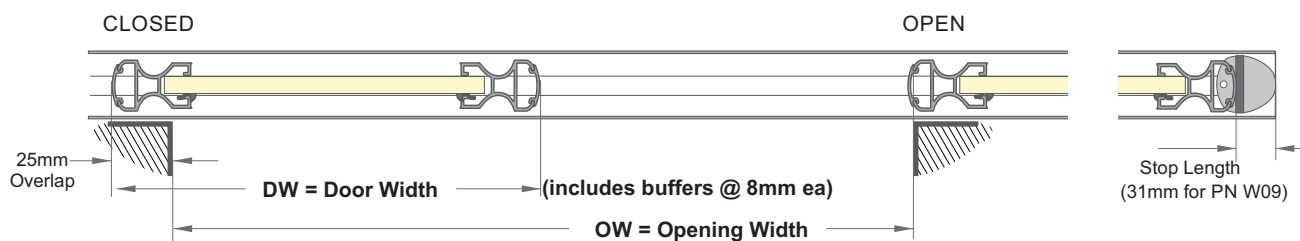

Typical Horizontal Cross Section Single Track - Face Mount

SINGLE TRACK, ONE, TWO DOORS, CUTTING FORMULA

DOOR WIDTHS - ONE DOOR		Part	Formula in mm
1	Single Head Track	4221	$2 \times OW + 141$
2	Single Bottom Track	4214	$2 \times OW + 141$
3	Single Door, Overall Width = DW		$OW + 50 (= DW)$

DOOR WIDTHS - TWO DOORS			
1	Single Head Track	4221	$2 \times OW + 117$
2	Single Bottom Track	4214	$2 \times OW + 117$
3	Single Door, Overall Width = DW		$OW/2 + 25 (= DW)$

RAIL, INFILL WIDTHS			Using Stile 4215	Using HD Stile 4212
1	Door , Top, Bottom Rail	4216	$DW - 72$	$DW - 75$
2	Infill, MDF, Meltica, Gib, Grooved Aluminium Panel	NA	$DW - 50$	$DW - 52$
3	Glazing Wedges (1mm - D13 , Green, Orange)	←	$DW - 50$	$DW - 52$
4	Infill, 4mm Mirror, Safety Glass	NA	$DW - 56$	$DW - 58$
5	Glass Gasket	D04	$DW - 56$	$DW - 58$
6	Door ,Mid Rail	4222	$DW - 72$	$DW - 75$

Note : Mirror, Glass panel size imitations . Refer to page 3

Juralco 4200 Wardrobe and Door Systems - Cutting

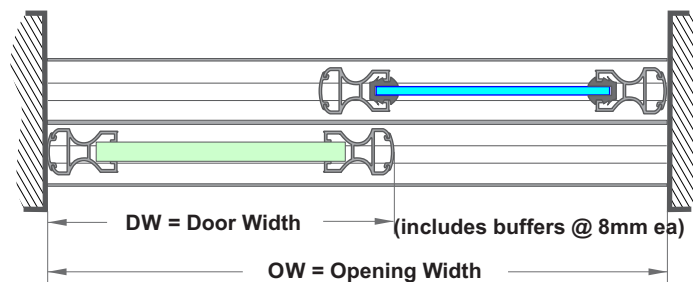

Typical Horizontal Cross Section Double Track - Under Jamb Mount

DOUBLE TRACK, TWO DOORS, CUTTING FORMULA

	DOOR WIDTHS	Part	Form ula in m m
1	Double Head Track	4218	OW
2	Double Bottom Track	4217	OW
3	Single Door - Overall Width = DW		OW / 2 + 18 (= DW)

	RAIL, INFILL WIDTHS		Using Stile 4215	Using HD Stile 4212
1	Door , Top, Bottom Rail	4216	DW - 72	DW - 75
2	Infill, MDF, Meltica, Gib, Grooved Aluminium Panel	NA	DW - 50	DW - 52
3	Glazing Wedges (1mm - D13 , Green, Orange)	←	DW - 50	DW - 52
4	Infill, 4mm Mirror, Safety Glass	NA	DW - 56	DW - 58
5	Glass Gasket	D04	DW - 56	DW - 58
6	Door ,Mid Rail	4222	DW - 72	DW - 75

Note : Mirror, Glass panel size imitations . Refer to page 3

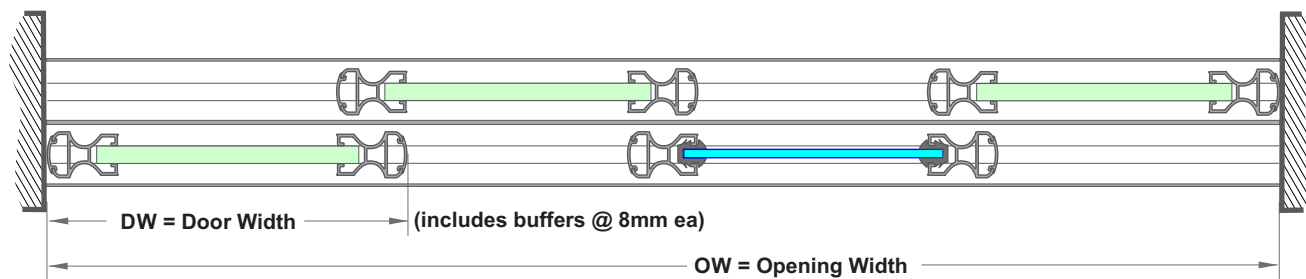

Typical Horizontal Cross Section Double Track - Under Jamb Mount

DOUBLE TRACK, FOUR DOORS, CUTTING FORMULA

	DOOR WIDTHS	Part	Form ula in m m
1	Double Head Track	4218	OW
2	Double Bottom Track	4217	OW
3	Single Door , Overall Width = DW		OW / 4 + 27 (= DW)

	RAIL, INFILL WIDTHS		Using Stile 4215	Using HD Stile 4212
1	Door , Top, Bottom Rail	4216	DW - 72	DW - 75
2	Infill, MDF, Meltica, Gib, Grooved Aluminium Panel	NA	DW - 50	DW - 52
3	Glazing Wedges (1mm - D13 , Green, Orange)	←	DW - 50	DW - 52
4	Infill, 4mm Mirror, Safety Glass	NA	DW - 56	DW - 58
5	Glass Gasket	D04	DW - 56	DW - 58
6	Door ,Mid Rail	4222	DW - 72	DW - 75

Note : Mirror, Glass panel size imitations . Refer to page 3

Juralco 4200 Wardrobe and Door Systems - Cutting

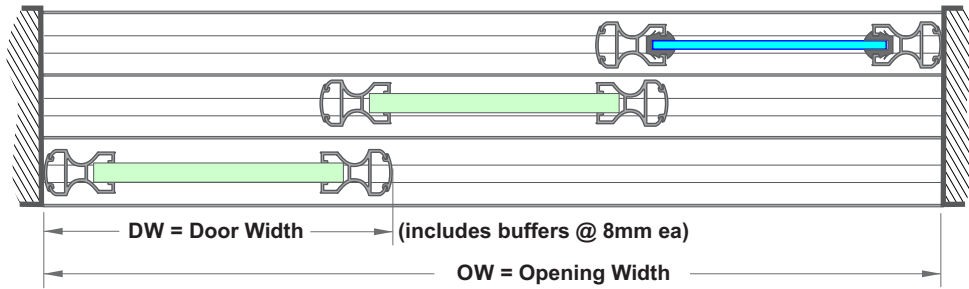

Typical Horizontal Cross Section Triple Track - Under Jamb Mount

TRIPLE TRACK, THREE DOORS, CUTTING FORMULA

	DOOR WIDTHS	Part	Formula in mm
1	Triple Head Track	4228	OW
2	Triple BottomTrack	4227	OW
3	Single Door , Overall Width = DW		OW / 3 + 24 (= DW)

	RAIL, INFILL WIDTHS		Using Stile 4215	Using HD Stile 4212
1	Door , Top, Bottom Rail	4216	DW - 72	DW - 75
2	Infill, MDF, Meltica, Gib, Grooved Aluminium Panel	←	DW - 50	DW - 52
3	Glazing Wedges (1mm - D13 , Green, Orange)	NA	DW - 50	DW - 52
4	Infill, 4mm Mirror, Safety Glass	NA	DW - 56	DW - 58
5	Glass Gasket	D04	DW - 56	DW - 58
6	Door ,Mid Rail	4222	DW - 72	DW - 75

Note : Mirror, Glass panel size imitations . Refer to page 3

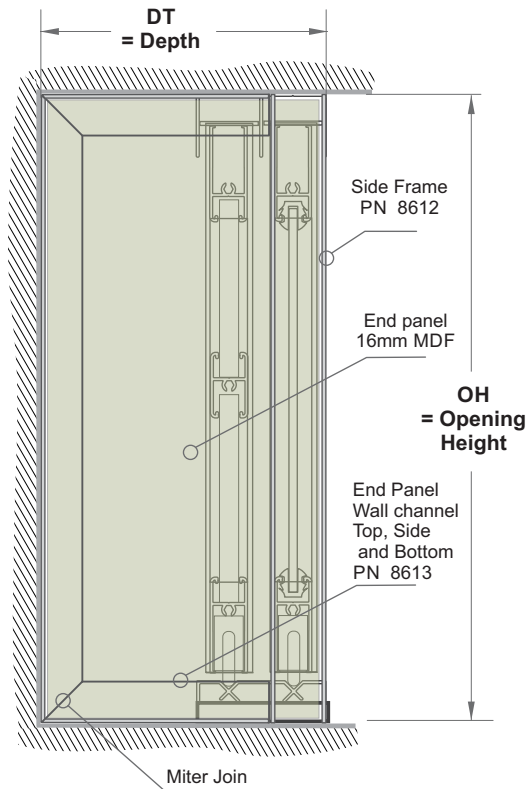

END PANELS, CUTTING FORMULA

	END PANELS	PART	Formula in mm
1	Side Frame - Height	4230	OH
2	Wall Channel - Height (Miter ends)	4230	OH
3	Wall Channel - Depth (1 x Miter end)	4230	DT - 28
4	Infill - 16mm MDF - Height	NA	OH - 4
5	Infill - 16mm MDF - Depth	NA	DT - 20

Juralco 4200 Wardrobe and Door Systems - Assembly, Setout

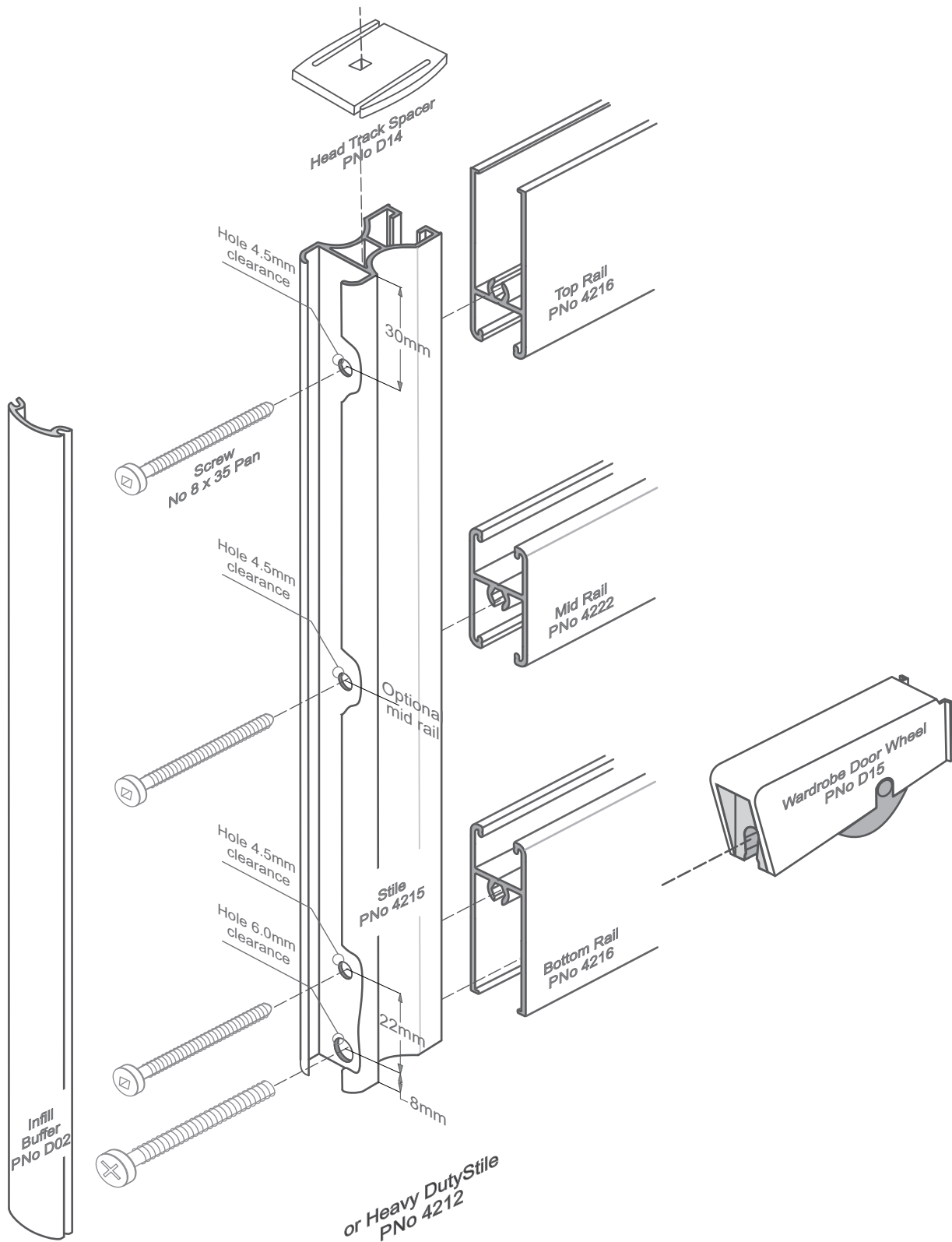

Manufacturing

- 1 - Hands must be clean and free from oils and grease.
- 2 - Inspect aluminium extrusions to ensure they are free of extrusion or surface finishing defects
- 3 - Cut aluminium extrusions to size as per cutting formula schedule.
- 4 - Drill stiles for the rails and wheels - 4.5mm and 6mm clearance holes
- 5 - Cut infill to size as per cutting formula.

Assembly

- 1 - Ensure work area is clean and free from chips and dust. Hands must be clean and free from oils and or grease.
- 2 - Fit D15 wheels into bottom rail at each end (screw removed)
- 3 - Infills

Mirror- 4mm - Place on 30mm blocks, run the D04 Glass Gasket all the way around joining at the centre top.
Do not overstretch the gasket as it may pull away at the join. Assemble Stiles to each side

Seratone - 4.75mm. Place on 30mm blocks. Assemble Stiles to each side. Run Wedge/Green around all backside of panel-6mm .
Place on 30mm blocks. Assemble Stiles to each side. run Wedge/Orange around all backside of panel

Meltica - 9mm - Place on 30mm blocks. Assemble Stiles to each side. Insert D13 Wedges (200mm strips at 400mm CL) to backside of panel

Gib - 10mm- Place on 30mm blocks. Assemble Stiles to each side. Fits neatly in extrusion gap.

Seal back of Gib with RTV

- 4 - Center and press on both Stiles evenly
- 5 - Press on both Top and Bottom Rails.
- 6 - Screw Top and Bottom Rails into place, ensuring all joints are clean and even. Attach Screw to D15 Wheel
- 7 - Attach selected D02 Rubber Buffers to Stiles
- 8 - Clean off all fingermarks, pack carefully

Installation

- 1 - Screw Head Track firmly in place
- 2 - Plumb down to Track, then panel bond/screw it into position
- 3 - Attach D14 Head Channel Spacers in position at top of door stiles
- 4 - Lift doors up into Head Track, then drop Door/Wheels onto bottom Track
- 5 - True up doors by adjusting D15 Wheel height (Remove D02 Rubber Buffer if necessary)
- 6 - Clean off all fingermarks