

JURALCO LOUVRELITE[®] SOLAR CONTROL SYSTEMS

ISSUE 3-23 v1

Juralco Aluminium Building Products Ltd designs and distributes specialist aluminium joinery systems through a national network of franchised fabricators and agents.

For more than 25 years we have been at the forefront of specialist aluminium door and window products suitable for New Zealand joinery and building methods. Our comprehensive product range includes security and insect screens, balustrades and gates, shutters and awnings, shower screens, wardrobe doors and organisers and internal doors.

The Juralco Louvre[®] Solar Control Systems combines a contemporary Aluminium frame with adjustable angle and spacing for the Aluminium elliptical shade louvres . The system is extremely versatile and can be custom made in a range of configurations and powder-coat colours to meet most modern architectural requirements.

As with all Louvre based Solar control systems the big compromise is between the light and spaciousness of an unobstructed view from a clear window as opposed to the typical NZ harsh unwanted direct sunlight and the accompanying excess heating. Designing a suitable exterior louvre system that gives light and spaciousness, while minimising the effects of direct sun light and heat is a challenge.

Shading for summer sun especially mid morning to late afternoon is a must. Winter sun on the other hand might only need shading during the middle of the day. Because summer sun is at high angles (apart from late afternoon/early evening - after normal work hours) and winter sun is at much lower angles, these seasons can be catered for. The use of Sun path diagrams for louvre angle and spacing calculations is essential.

Using the Louvre[®] Solar Control system together with appropriate the louvre, spacing and angle selection, all contained in a frame, oriented correctly will bring the best solution.

If however the louvres are being placed on a blank wall, purely for aesthetic reasons, then any spacing agreed on will suffice.



Juralco LouvreLite® Solar Control Systems

Pages	Codes	Description	Use the Bookmarks List to jump to selected pages
4 - 5	Materials	80mm, 120mm, 150mm (2), 200mm and 250mm Louvre Extrusions and Components	
6 - 10	Mountings	Shows a range of possible Spans, overhangs and Louvre attachments types	
11 - 13	Sun Angle Charts	Shows Sun angles and bearings for differing times of day and season. Upper half NI, Auckland. Lower half NI, Wellington. Upper half SI, Christchurch. Lower half SI, Dunedin.	
14 - 18	Horizontal View Tables	Shows a range Shading and Louvre Vertical setouts at 30deg and 45deg tilt down	
19	Elevation Dimensions	Shows Vertical and Horizontal Louvre sets; dimension boundaries	
20 - 33	Mountings	Shows typical mountings to various Wall systems	
34 - 37	Sun Charts	Sun Charts for printing off, for calculations	
38 - 47	150 x 50 Rectangular	Shows making a 150x50mm Louvre [project	
48 - 51	Louvre Shapes	Shows a range of Curtain Wall standard Louvre shapes	
52	Powder Coat	Instructions for the Care and Maintenance of Powder Coated surfaces	

New from Jan 2023. Important instructions for Powder Coatings near Salt Water

The new standard Dulux powder coating systems used by Juralco are:

- Duralloy® (to be phased out) for structures greater than 100m from high tide and up to 3 stories high. Duralloy® has a 10 yr warranty.
- Duralloy Plus® (full Duralloy® colour range) for structures greater than 10m from high tide and up to 3 stories high. Duralloy Plus® has a 15 yr warranty.
- Duratec® for prestigious residential and commercial developments over 10m from high tide and over 3 stories high. Duratec® has a 25yr warranty.

For all other applications contact Juralco for alternative systems.

Note - Powder coated prices listed in Juralco price books are for Duralloy® or Duralloy Plus® systems. If the Duratec® system is required it must be specified upon placement of the order and will incur a surcharge – Duratec® prices on application.

Important instructions for Powder Coating - Attachment to structures

PVC Tape or similar material spacer must be used to separate powder coated aluminium items from all concrete and steel structures.

Failure to do so can lead to the chemicals in the structure affecting the powder coating layer on the aluminium, leading to corrosion.

Powder Coating Warranty

The Dulux powder coating warranty period is conditional upon the surface being maintained in accordance with the Dulux 'Care and Maintenance Instructions'. Contact your installer for a copy, download from Dulux or refer to the back page of this manual.

**Juralco LouvreLite® Solar Control Systems
Extrusions**

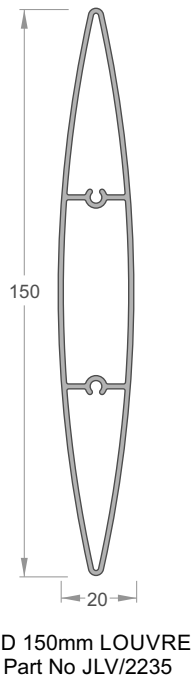
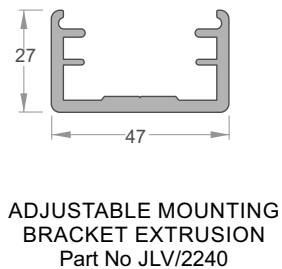
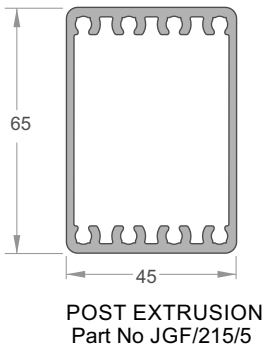
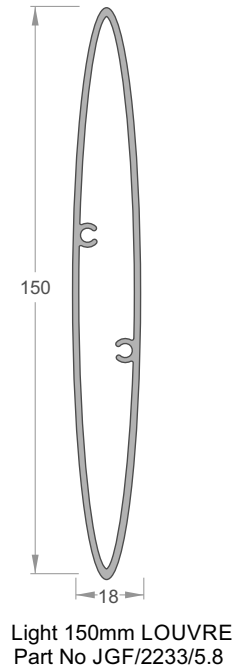
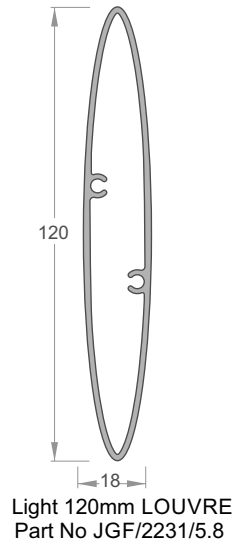
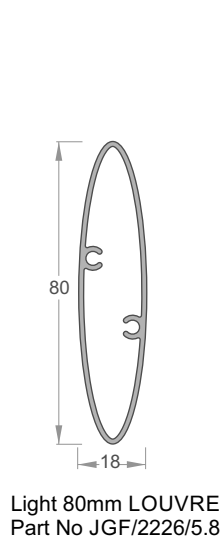

Note HD = Heavy Duty

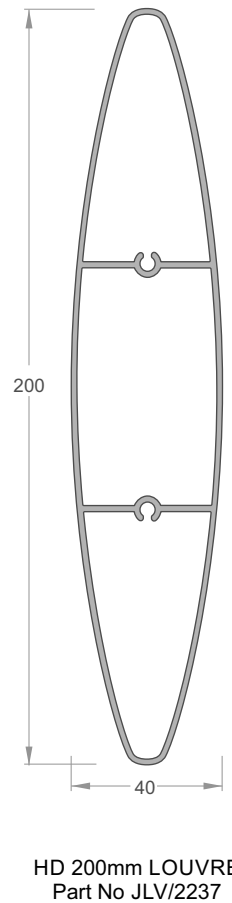

Note HD = Heavy Duty

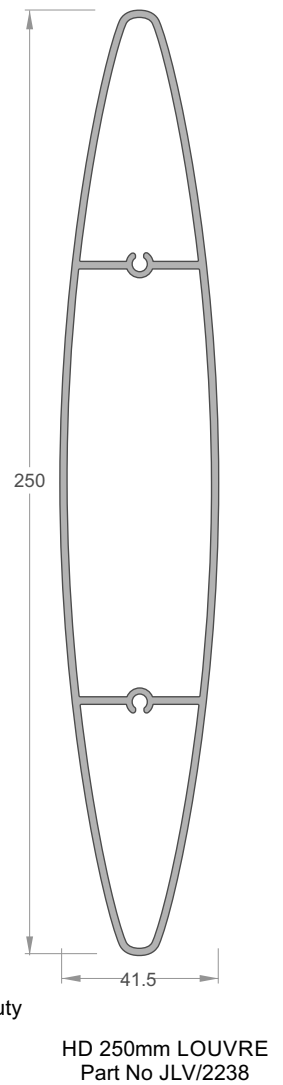

Note - All Extrusions Half size

Juralco Louvelite® Solar Control Systems

Components

Adjustable Mounting Bracket Part No JLV/L01/40

M10 Louvre Clamp Screws included with Adjustable Brackets

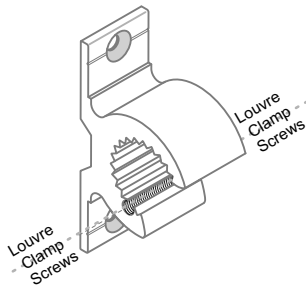

40mm wide x 120mm high x 70mm deep

Adjustable Mounting Rear Clamp Bracket Part No JLV/L03

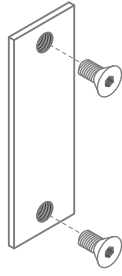

40mm wide x 120mm high x 3mm deep (threads 6mm deep)

80-120-150mm Louvre Adjustable Bracket Part No JLV/L15/40

40mm wide

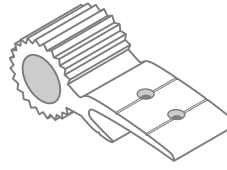

These can be mounted on the Topside or Underside of a Louvre. Topside configuration shown. If over Windows, Topside mounting is recommended

Includes 2 x M10x16 Button Head - Louvre Clamp Screws + No8 x 8C/s SS PK screws

200-250mm Louvre Adjustable Bracket Part No JLV/L25/40

40mm wide

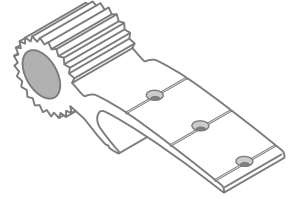

These can be mounted on the Topside or Underside of a Louvre. Topside configuration shown. If over Windows, Topside mounting is recommended

Includes 2 x M10x16 Button Head - Louvre Clamp Screws + No8 x 8C/s SS PK screws

80-120-150mm Louvre Adjustable Double Bracket Part No JLV/L15/80

80mm wide

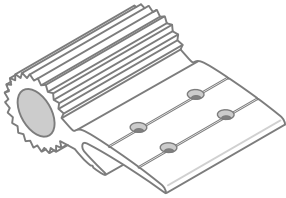

These can be mounted on the Topside or Underside of a Louvre. Topside configuration shown. If over Windows, Topside mounting is recommended

Includes 2 x M10x16 Grub Screws - Louvre Clamp screws and No8 x 8 C/s SS PK screws

200-250mm Louvre Adjustable Double Bracket Part No JLV/L25/80

80mm wide

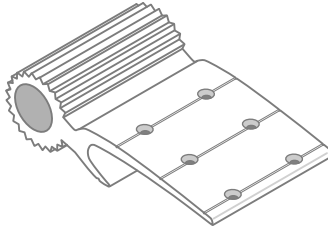

These can be mounted on the Topside or Underside of a Louvre. Topside configuration shown. If over Windows, Topside mounting is recommended

Includes 2 x M10x16 Grub Screws - Louvre Clamp screws and No8 x 8 C/s SS PK screws

Fastenings



Adjustable Brackets to Louvres
No8 x 8C/S SS



End Covers to Light 80-150mm Louvre
No 8 x 12CS SS

End Covers to 150-250mm Louvre
No10 x 12CS SS

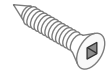

End Covers + Light 80-150mm Louvres to End Frames
No 8 x 25CS SS

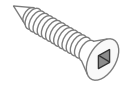

End Covers + 150-250mm Louvres to End Frames
No10 x 25CS SS

Base plate Part No JLV/BP188

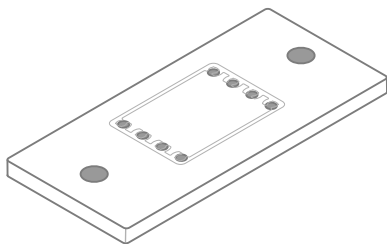

180mm x 80mm x 10mm - 2 x hole

Base plate Part No JLV/BP180

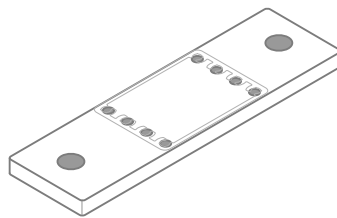

180mm x 50mm x 10mm - 2 x hole

Louvre Mount Bracket Part No JLV/L12/30

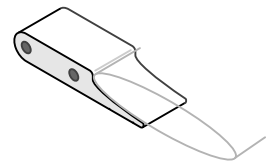

30mm wide x 80mm long

Louvre End Covers

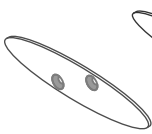

Light 80mm Louvre End Cover
Part No JLV/L80EC

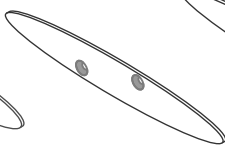

Light 120mm Louvre End Cover
Part No JLV/L120EC

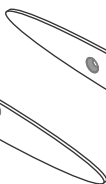

Light 150mm Louvre End Cover
Part No JLV/L151EC

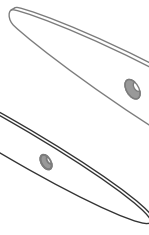

HD 150mm Louvre End Cover
Part No JLV/L150EC

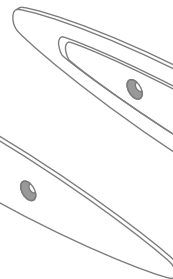

HD 200mm Louvre End Cover
Part No JLV/L200EC

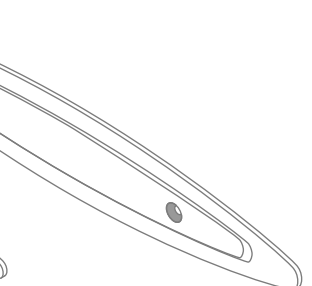

HD 250mm Louvre End Cover
Part No JLV/L250EC

Juralco Louvrelite® Solar Control Systems

Louvre Types, Spans and Overhangs

Louvre Sizes, Applications

This mainly determined by the availability of Building Fixings and the size of the job.

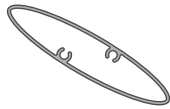

Light 80mm Louvres
- For Small/Residential applications
Unsupported span max 1.5m

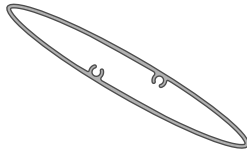

Light 120mm Louvres
- For Small/Residential applications
Unsupported span max 1.8m

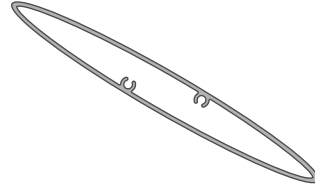

Light 150mm Louvres
- Mainly for Medium /Residential applications
Unsupported span max 2.0m

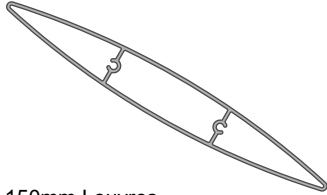

HD 150mm Louvres
- Mainly for Small/Commercial applications
Unsupported span max 2.0m

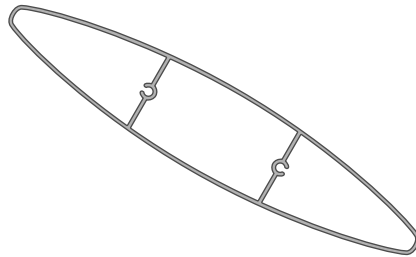

HD 200mm Louvres
- Mainly for Medium/Commercial applications
Unsupported span max 2.5m

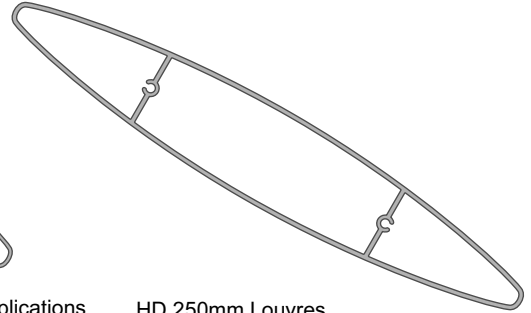

HD 250mm Louvres
- Mainly for Larger /Commercial applications
Unsupported span max 3.0m

Light 80,120 &150mm Louvres. Span, Overhang

Light 120mm Louvre Shown

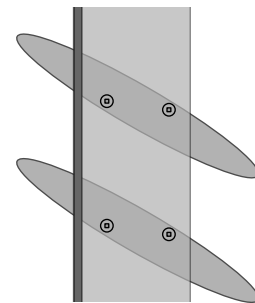
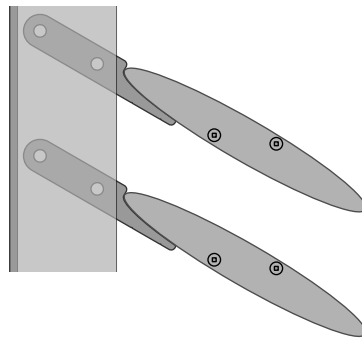

Light Louvre mm	Span, max mm	Overhang, max mm
80	1500	300
120	1800	400
150	2000	500

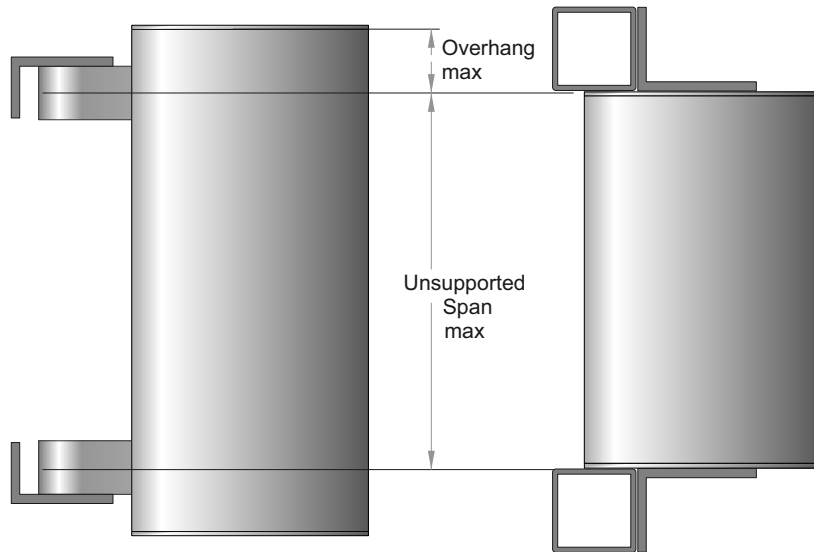

Non Adjustable Louvre Mount Bracket and Vertical Angles

Non Adjustable End Mount to suitable Vertical Angle And SQ Steel Hollow

Juralco LouvreLite® Solar Control Systems
Louvre Attachment

HD 150, 200 & 250mm Louvres.
 Span, Overhang

HD Louvre mm	Span, max mm	Overhang, max mm
150	2000	500
200	2500	600
250	3000	700

250mm Louvre Shown

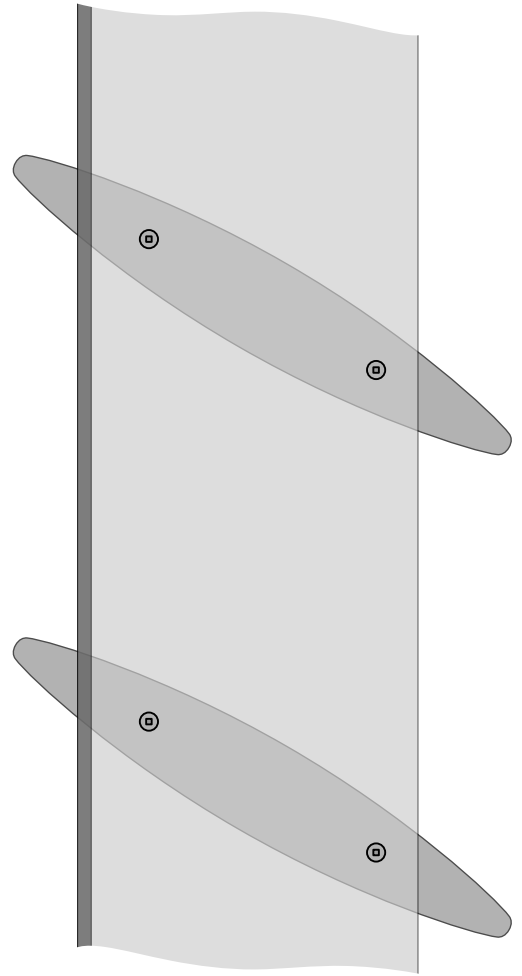
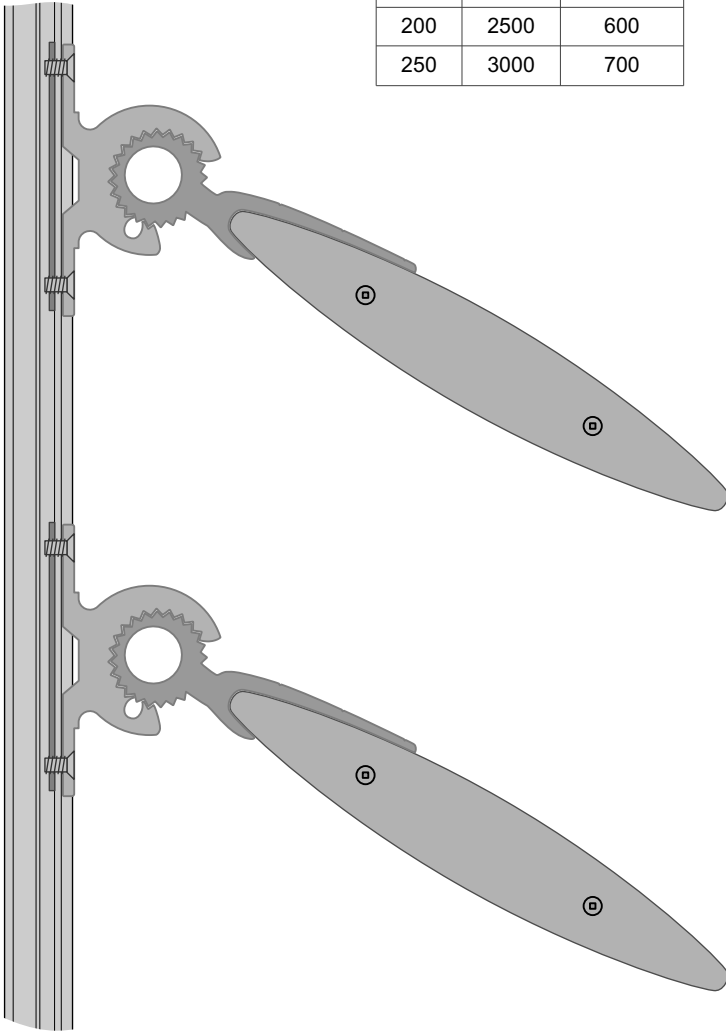

Unsupported
 Span
 max

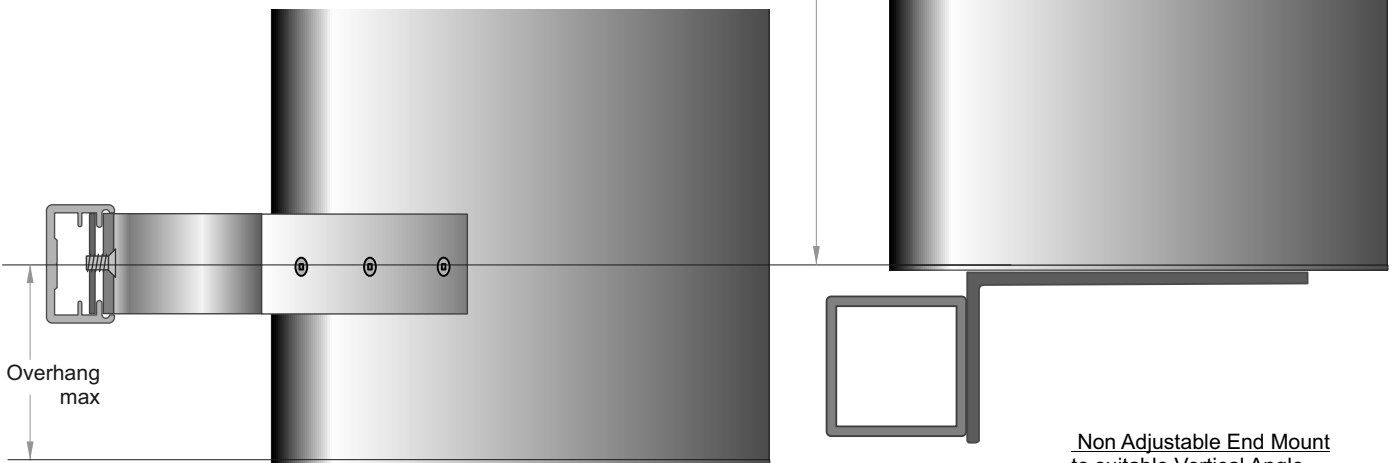

Adjustable Mounting
 Bracket Extrusion and spaced
 Louvre Adjustable Brackets.

Non Adjustable End Mount
 to suitable Vertical Angle
 And Sq Steel Hollow

Juralco Louvelite® Solar Control Systems

Louvre Attachment

Frame System Options.
Adjustable Spacing and Angle

Note : The Louvre Adjustable Brackets can be mounted to the Topside or Underside of the louvre.

Topside mounts shown. Normal mount if directly over windows

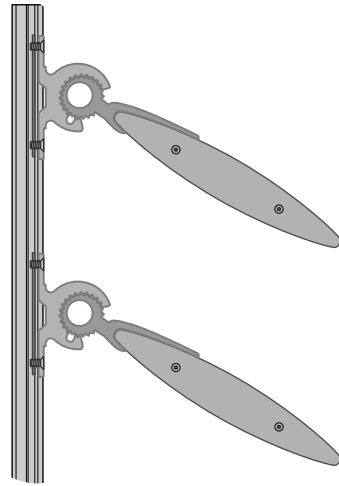

Adjustable Spacing and Adjustable Louvre Angle Brackets mounted to the Topside of Louvre

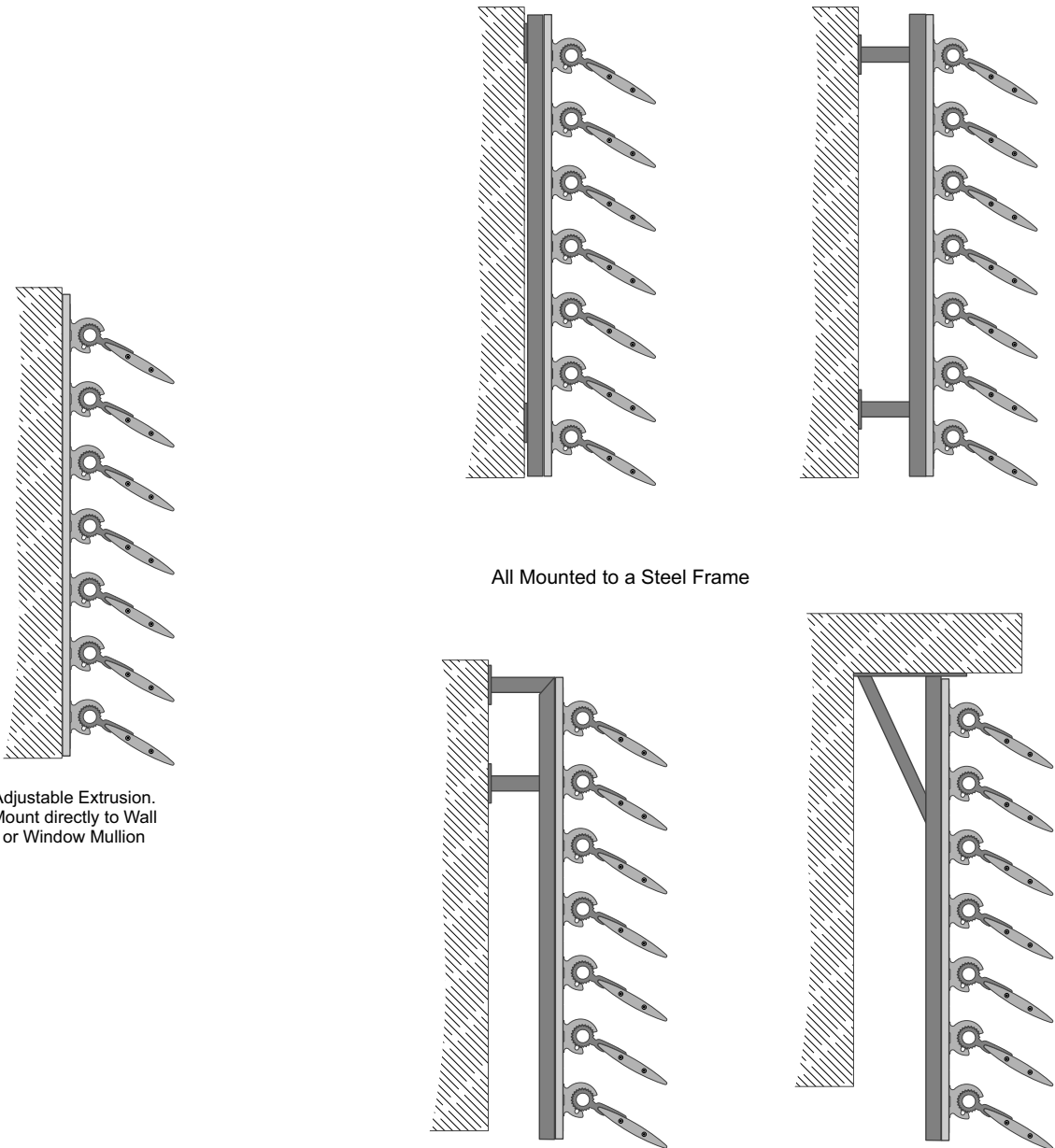

Adjustable Extrusion. Mount directly to Wall or Window Mullion

All Mounted to a Steel Frame

Juralco Louvre[®] Solar Control Systems

Louvre Attachment

Frame System Options.
Adjustable Spacing and Angle
Angled Backing

Note : The Louvre Adjustable Brackets can be mounted to the Topside or Underside of the louvre.
Topside mounts shown. Normal mount if directly over windows

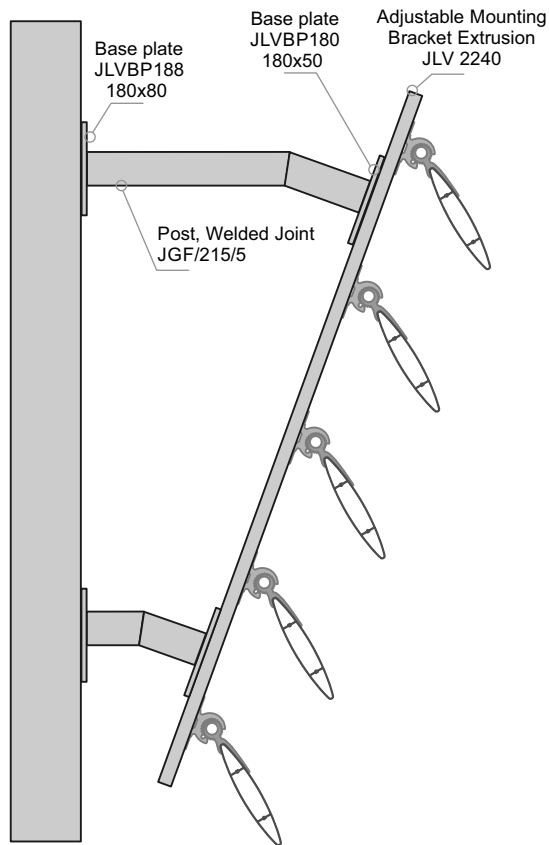
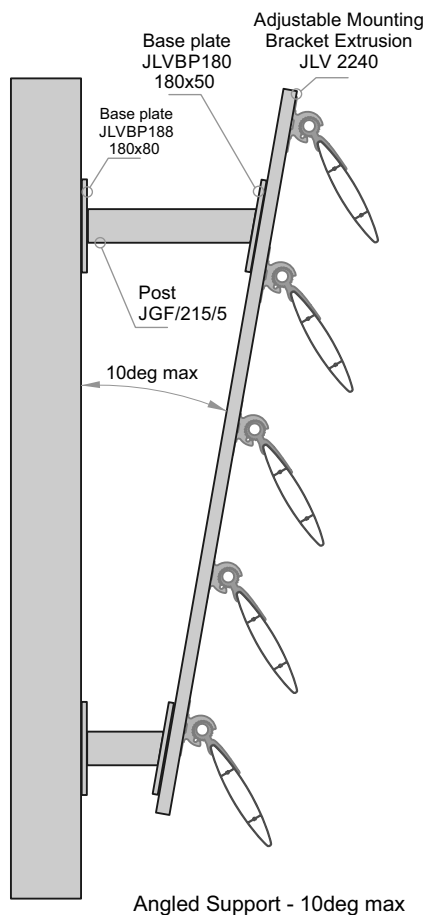
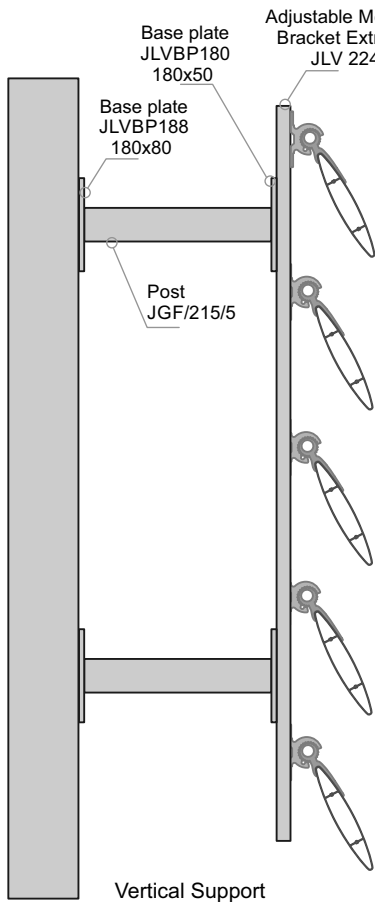

Juralco Louvrelite® Solar Control Systems

Louvre Attachment

Frame System Options.
End Fixed Louvres

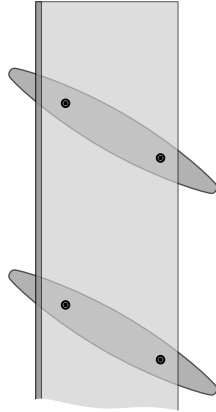

Fixed Spacing and Fixed Angle Louvres

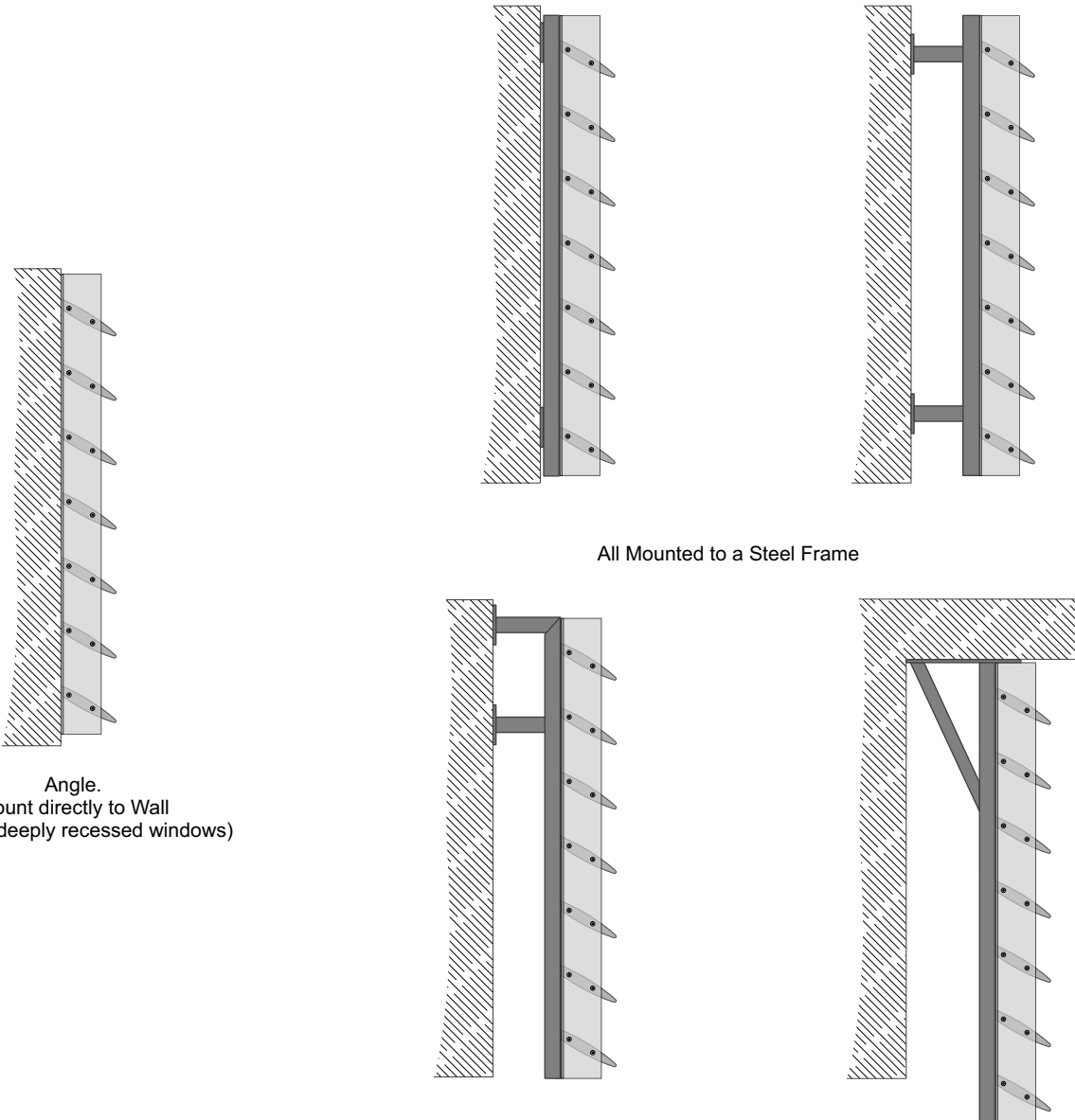

Angle.
Mount directly to Wall
(Only for deeply recessed windows)

All Mounted to a Steel Frame

Juralco Louvelite® Solar Control Systems

Design Parameters

All the following Design parameters must be considered before manufacture.
All this information relates to a Vertical Mounting Frame containing Horizontal angled louvres

All the necessary steps below are explained in the order listed below, in the next 9 pages.

- 1 - What **Area in NZ** is the installation situated? Sun conditions are very different from the top to bottom of New Zealand.
 Sun Angle Charts are available for..
 - a - Top half of the NI, including Auckland.
 - b - Bottom half of the NI, including Wellington.
 - c - Top half of the SI, including Christchurch
 - d - Bottom half of the SI, including Dunedin.
- 2 - What is the **Window Facing Direction**? Does the Window face East, NE, North, NW or West.
 The sun can only enter a window +, - 90deg from this window facing direction.
- 3 - What amount of shading is required? **Choosing the Sun Shading Angle**
 (Midwinter is the most critical time, with low sun angles during the day.
 Midsummer shading will always be whole day, even with minimal midwinter shading)
 - a - An Office room may require full shading from 8am to 5pm.
 - b - A Residential room may want some Midwinter sun, say shading only around the middle of the day.
 - c - Other significant surrounding structures will alter the shading pattern.
 All charts and calculations here assume clear horizons.
- 4 - What amount of **Horizontal Viewing** is required? (described as % open; 0% = completely closed, 100% = completely open)
 - a - An Office room may not think this important and be happy with maximum shading and minimum view, say 15%
 - b - A Residential room may want some views retained, say 50%
 For Multi storeyed buildings looking 'down' through the louvre gaps will enable a larger view, but this only applies to people close to the louvre screen.
- 5 - What **Louvre Size** is to be used?
 - a - Light 80-150mm Louvres - For Small/Residential applications, [see tables for unsupported spans](#)
 - b - Heavy Duty 150- 250mm Louvre - Mainly for Larger /Commercial applications, [see tables for unsupported spans](#)
- 6 - What combination of **Louvre Angle Setting** and **Spacing** are required to give the Shading and Viewing from above.
- 7 - What overall **Horizontal Dimension** for the Louvre Screen is required to shade all the window?
 This will always be greater than the window horizontal dimension. (For deeply recessed windows this maybe equal)
 This is most affected by the distance the louvre screen is mounted out from the window.
- 8 - What overall **Vertical Dimension** for the Louvre Screen is required to shade all the window?
 This will always be equal to or greater than the window vertical dimension. (For deeply recessed windows this maybe equal)
 This is most affected by the distance the louvre screen is mounted out from the window.
- 9 - What **Frame System** is most suitable.
 - a -The Adjustable Mounting Bracket Extrusion can be mounted directly to a building surface, or to a subframe which is then mounted to the building. Louvre angle and louvre spacing adjustable.
 - b - The louvres can be directly mounted at a fixed spacing and fixed angle to a subframe which is then mounted to the building.
- 10 - While you can work through the variables above to arrive at a solution, the System Structural Strength, Wind Zones, Sub Frame and Method of Attachment to a building will have to be passed by a Engineer

Sun Angle Chart explained

This particular chart is the for the Top Half NI/Auckland only.

There are 4 separate charts covering all NZ. Top half NI, Bottom Half NI, Top Half SI, Bottom Half SI.

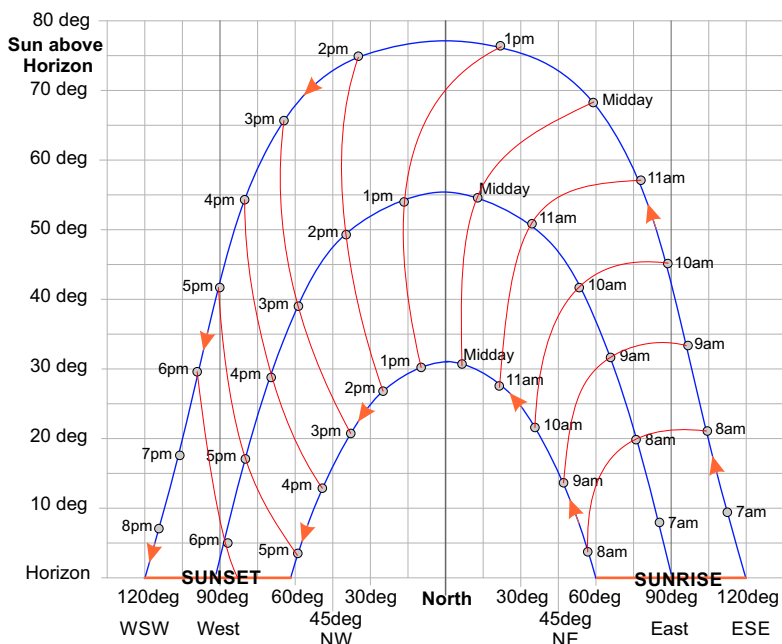

The chart shows the elevation angle above the horizon and angle around from north for the Sun at various times of the day for Midwinter, Midsummer and Spring/Autumn.

Controlling the Mid Winter sun is the critical factor and weighing shading versus view can be a difficult compromise.

There are larger charts for your use at the back of this Manual



Juralco Louvre[®] Solar Control Systems

Design Parameters

Window Facing Direction. **North** Sun Angle Chart.

This particular chart is the for the top Half NI/Auckland only.
This Chart for a North Facing Window only. Grey areas = No Sun

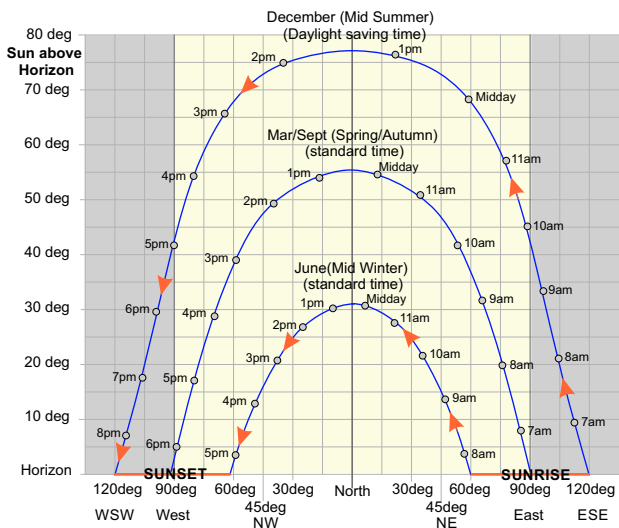

- This Window faces due North.
- The Sun can only first enter the window at 90deg to this.
- The Yellow area shows, with no louvres at all the Room will be in shade before about 10am and after about 5pm during Summer.
- For the rest of the year, the room will be in full Sun, sunrise to sunset.

Window Facing Direction. **East** Sun Angle Chart.

This particular chart is the for the top Half NI/Auckland only.
This Chart for a East Facing Window only. Grey areas = No Sun

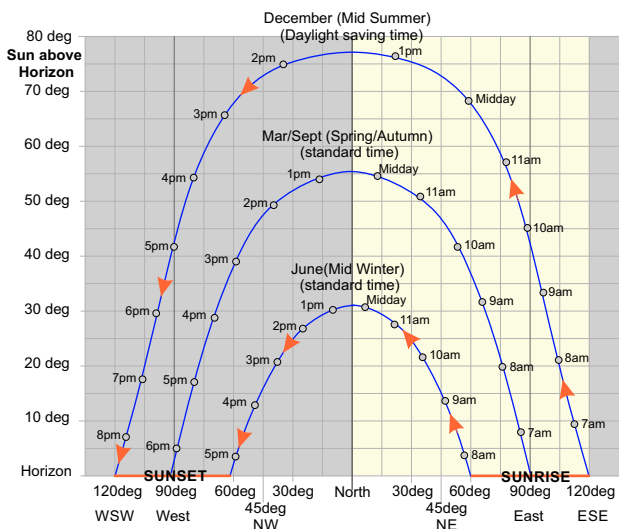

- This Window faces due East
- The Sun can only first enter the window at 90deg to this.
- The Yellow area shows, with no louvres at all the Room will be in full sun, sunrise to just after midday 12mths of the year

Window Facing Direction. **West** Sun Angle Chart.

This particular chart is the for the top Half NI/Auckland only.
This Chart for a West Facing Window only. Grey areas = NO Sun

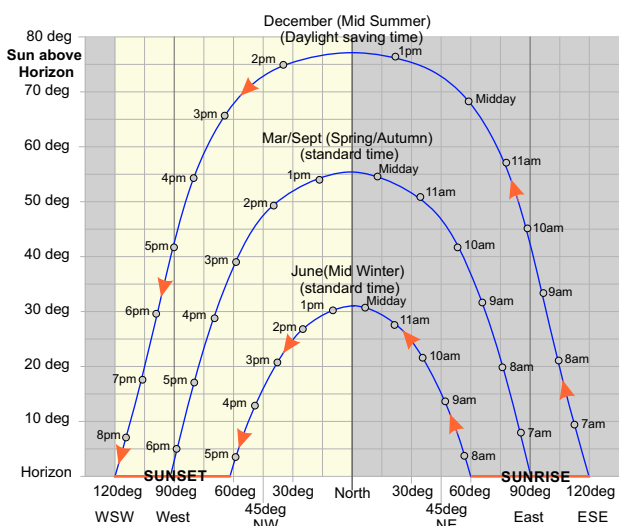

- This Window faces due WEST
- The Sun can only first enter the window at 90deg to this.
- The Yellow area shows, with no louvres at all the Room will be in full sun, just after midday to sunset 12mths of the year

Juralco LouvreLite® Solar Control Systems

Design Parameters

Choose Shading Sun Angle.
Sun Angle Chart.

This particular chart is the for the top Half NI/Auckland only.
This Chart for a North Facing Window only

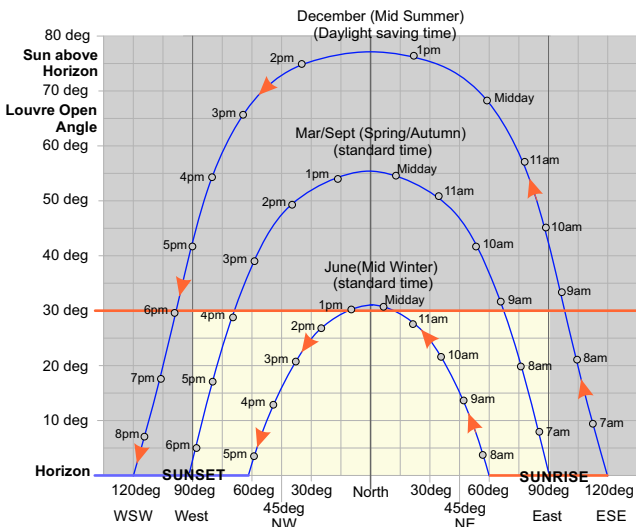

To use charts....

1 - Decide on **Sun Shading Start/Finish times for Winter**, then draw a horizontal line through these start and finish times.

Example shown (June/Mid Winter, 1 hr midday shading = line @ 30 deg)
Winter - Sun in room all day, apart from about 1hr at about midday.
Spring, Autumn - Sun enters room sunrise to about 9-10am, then Shading Starts. Shading finishes at about 4-5pm and sun enters the room until sunset.
Summer - Shading All Day

This all follows from the horizontal line at 30deg. (= **Louvre Open Angle**)
 Drawing this line higher up say 40deg gives more sun/less shading, more view
 Drawing this line lower down say 20 deg gives more shading/less sun, less view

There are larger charts at the rear, suitable for printing off, to help calculations

Horizontal Viewing,
Louvre open angle

- 1 - Chosen Sun Angle = Louvre Open Angle = 30 deg in this example (from above)
- 2 - Louvre Tilt angle = 30deg and 45deg down in this example
- 3 - Both have the same shading performance; the 45 deg Louvre tilt down uses less louvres, but is more view obstructed

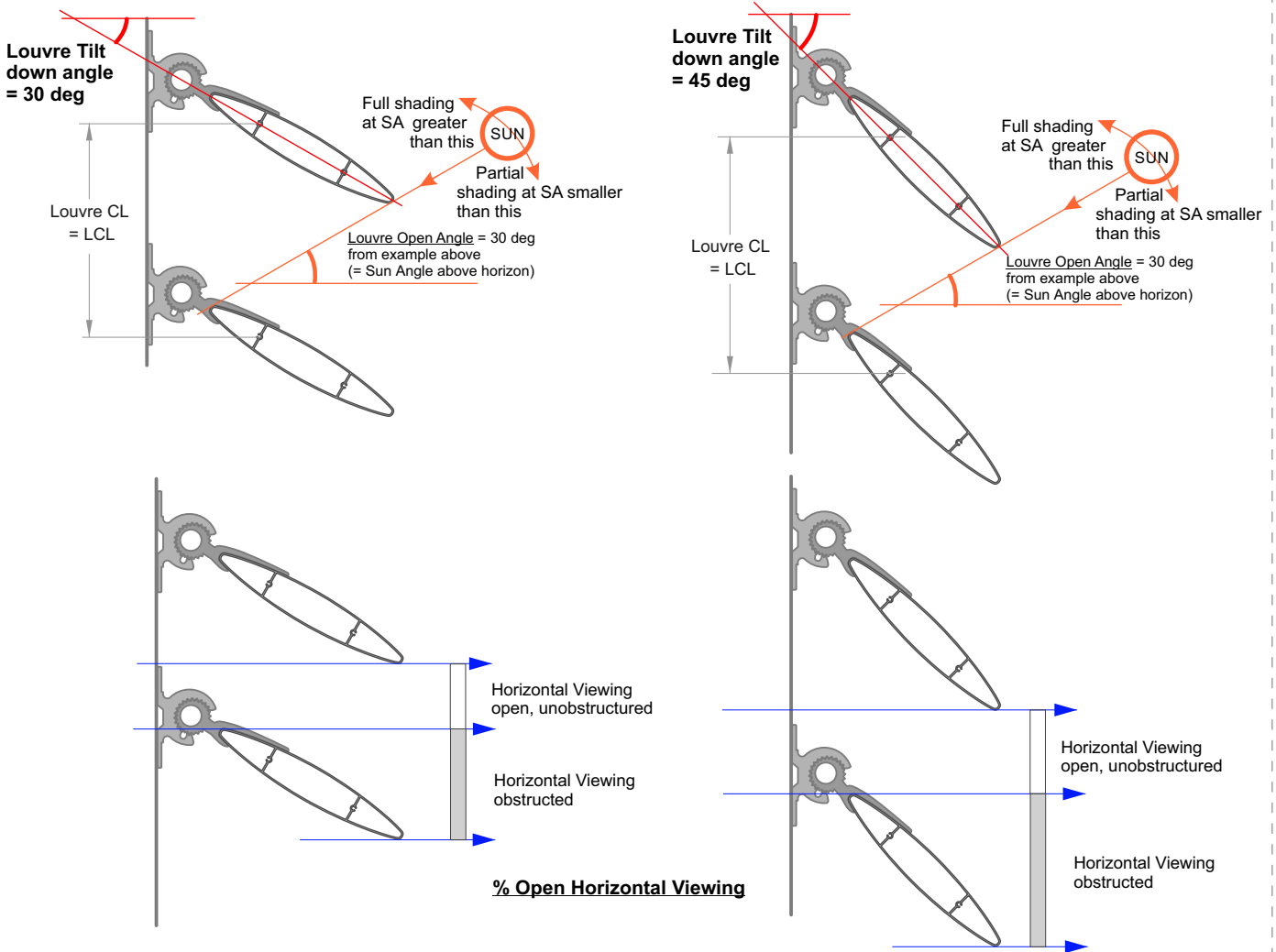

Please note - (1) The **Louvre Tilt Angle** refers to the Angle the Louvre is **Mechanically Set to: ie 15deg, 30deg, 45deg down**
 (2) The **Louvre Open Angle (= Sun Angle above the Horizon)** Set by the Distance the louvres are installed apart from each other. Refers to the angle from the top/inside of a louvre to the bottom/outside of the next louvre above. **This influences the View and the start of full Shading as the sun rises (= stopping of full shading as the sun sinks)**

Juralco Louvelite® Solar Control Systems

Horizontal Viewing Setouts

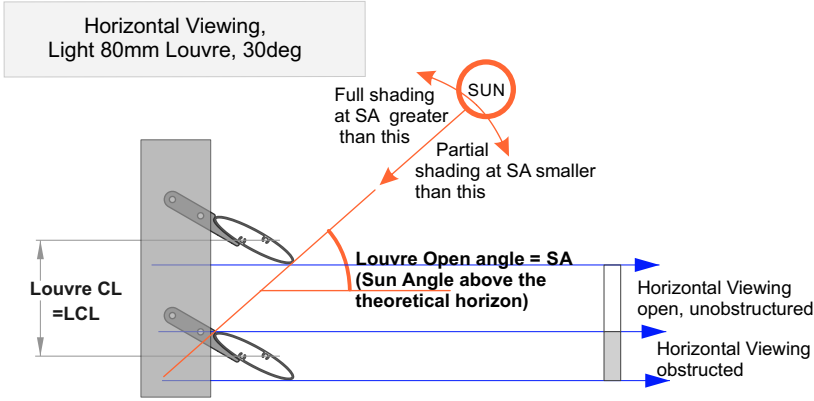

**Light 80mm Louvre
@30deg tilted down**

Louvre Open angle	LCL mm	% Open, Horiz view
10deg	NA	NA
20deg	70	40%
30deg	80	50%
40deg	100	60%
50deg	120	65%

Unsupported span max 1.5m

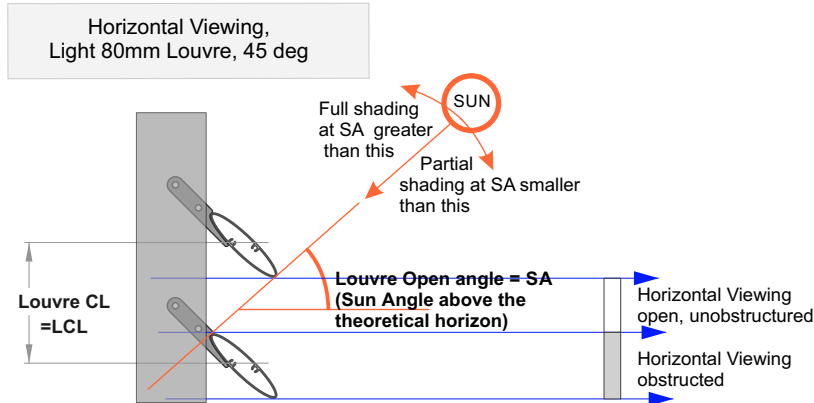

**Light 80mm Louvre
@45deg tilted down**

Louvre Open angle	LCL mm	% Open, Horiz view
10deg	NA	NA
20deg	80	30%
30deg	90	35%
40deg	105	45%
50deg	125	55%

Unsupported span max 1.5m

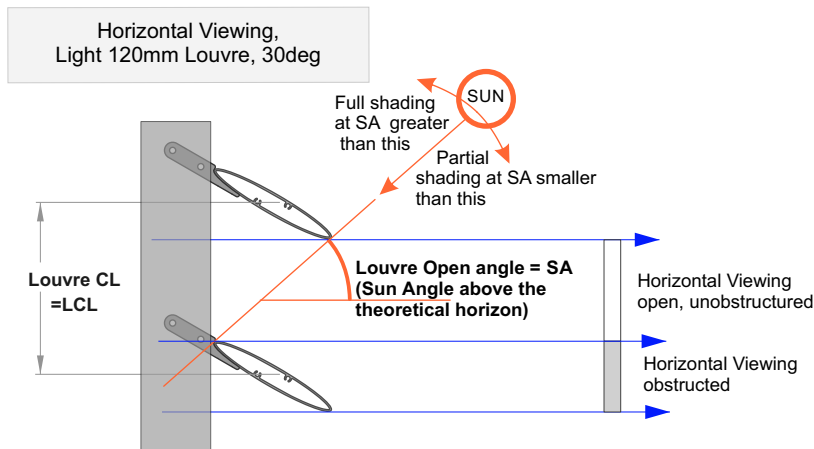

**Light 120mm Louvre
@30deg tilted down**

Louvre Open angle	LCL mm	% Open, Horiz view
10deg	80	25%
20deg	100	40%
30deg	120	50%
40deg	150	60%
50deg	185	65%

Unsupported span max 1.8m

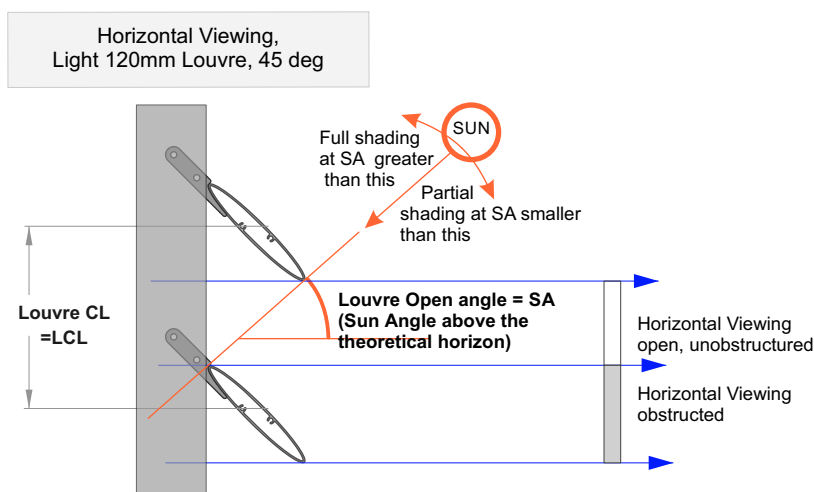

**Light 120mm Louvre
@45deg tilted down**

Louvre Open angle	LCL mm	% Open, Horiz view
10deg	100	15%
20deg	120	25%
30deg	135	40%
40deg	155	45%
50deg	185	55%

Unsupported span max 1.8m

Juralco Louvelite® Solar Control Systems

Horizontal Viewing Setouts

Horizontal Viewing,
Light 150mm Louvre, 30deg

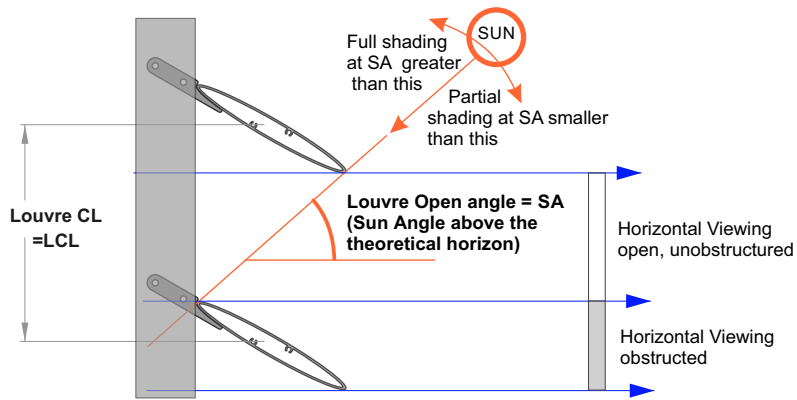

**Light 150mm Louvre
@30deg tilted down**

Louvre Open angle	LCL mm	% Open, Horiz view
10deg	NA	NA
20deg	120	35%
30deg	150	50%
40deg	180	60%
50deg	225	65%

Unsupported span max 2.0m

Horizontal Viewing,
Light 150mm Louvre, 45deg

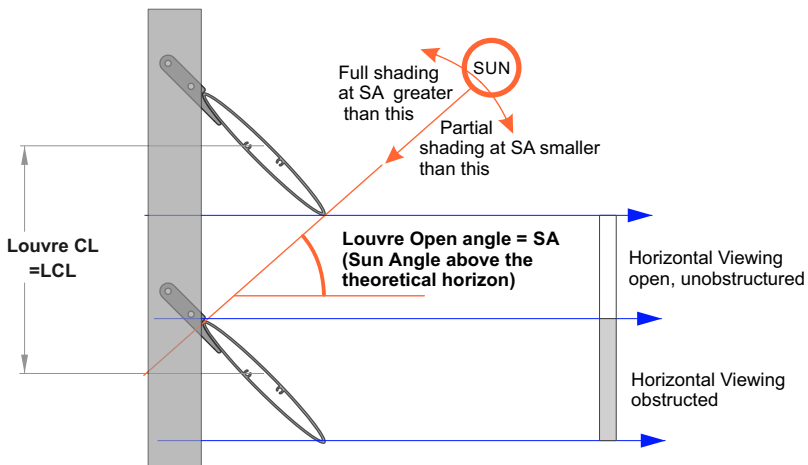

**Light 150mm Louvre
@45deg tilted down**

Louvre Open angle	LCL mm	% Open, Horiz view
10deg	NA	NA
20deg	145	25%
30deg	170	35%
40deg	195	45%
50deg	235	55%

Unsupported span max 2.0m

Juralco Louvelite® Solar Control Systems
Horizontal Viewing Setouts

Horizontal Viewing,
150mm Louvre, 30deg

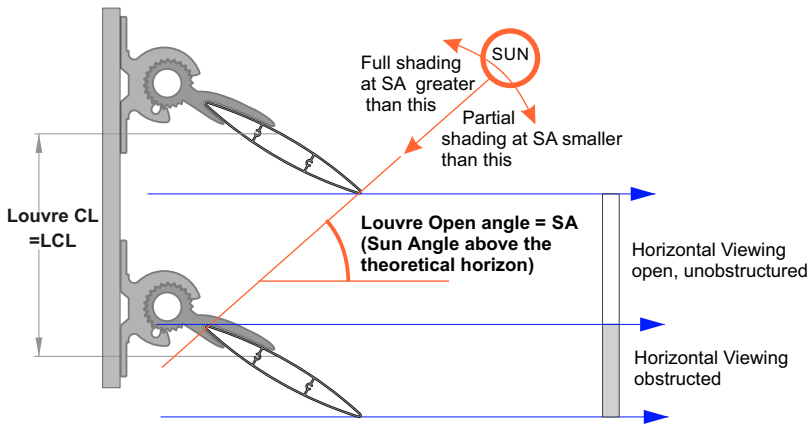

HD 150mm Louvre @30deg tilted down		
Louvre Open angle	LCL mm	% Open, Horiz view
10deg	NA	NA
20deg	120	35%
30deg	150	50%
40deg	180	60%
50deg	225	65%

Unsupported span max 2.0m

Horizontal Viewing,
150mm Louvre, 45deg

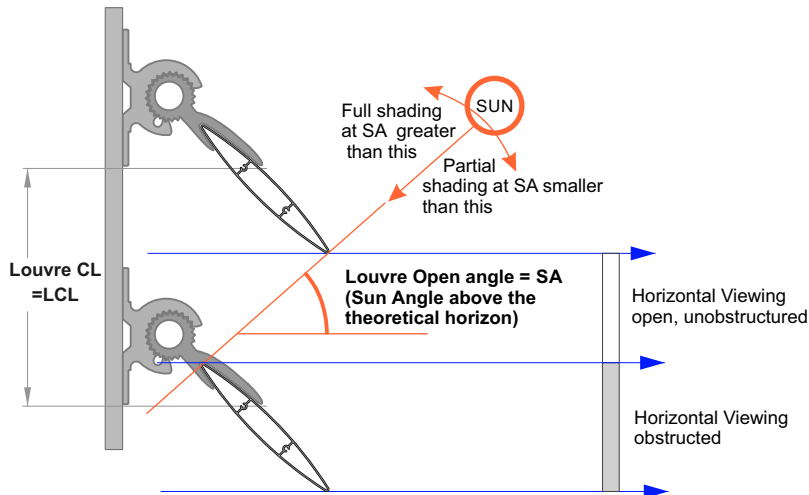

HD 150mm Louvre @45deg tilted down		
Louvre Open angle	LCL mm	% Open, Horiz view
10deg	NA	NA
20deg	145	25%
30deg	170	35%
40deg	195	45%
50deg	235	55%

Unsupported span max 2.0m

Juralco Louvrelite® Solar Control Systems

Horizontal Viewing Setouts

Horizontal Viewing,
200mm Louvre, 30deg

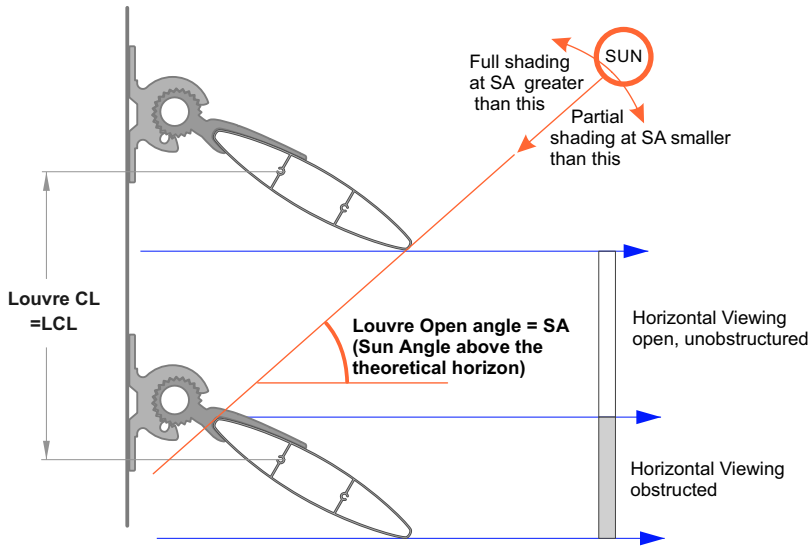

HD 200mm Louvre @30deg tilted down		
Louvre Open angle	LCL mm	% Open, Horiz view
10deg	135	15%
20deg	165	40%
30deg	200	50%
40deg	245	60%
50deg	305	65%

Unsupported span max 2.5m

Horizontal Viewing,
200mm Louvre, 45 deg

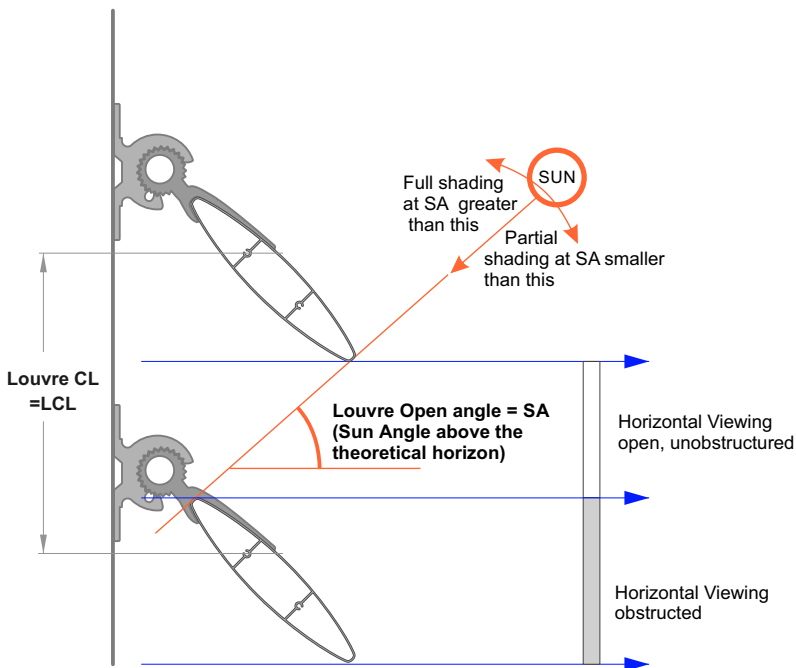

HD 200mm Louvre @45deg tilted down		
Louvre Open angle	LCL mm	% Open, Horiz view
10deg	165	35%
20deg	195	40%
30deg	225	50%
40deg	260	55%
50deg	305	60%

Unsupported span max 2.5m

Juralco Louvre[®] Solar Control Systems

Horizontal Viewing Setouts

Horizontal Viewing,
250mm Louvre, 30 deg

Large Louvre, Second setting = -30 deg
Standard Setting A

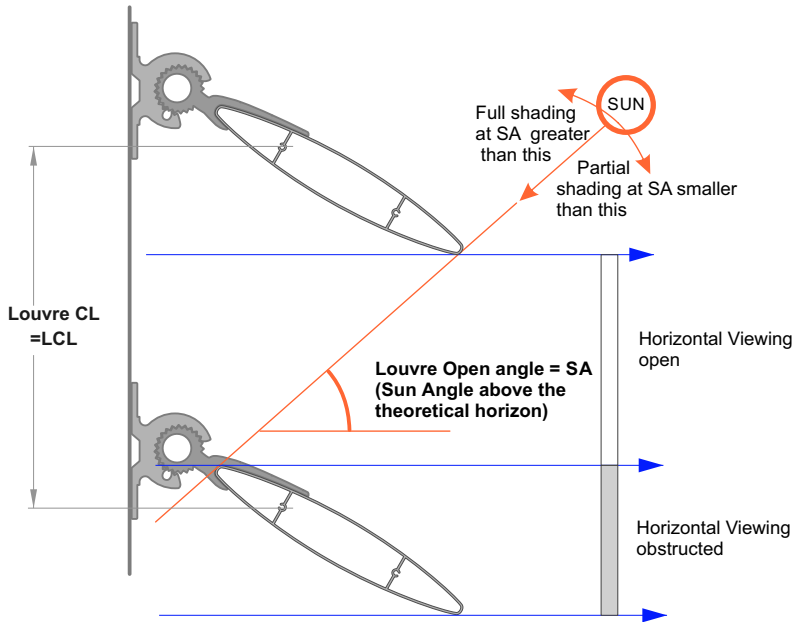

HD 250mm Louvre @30deg down		
Louvre Open angle	LCL mm	% Open, Horiz view
10deg	170	20%
20deg	210	35%
30deg	255	50%
40deg	310	60%
50deg	385	65%

Unsupported span max 3.0m

Horizontal Viewing,
250mm Louvre, 45 deg

Large Louvre, Second setting = -45 deg
Standard Setting B

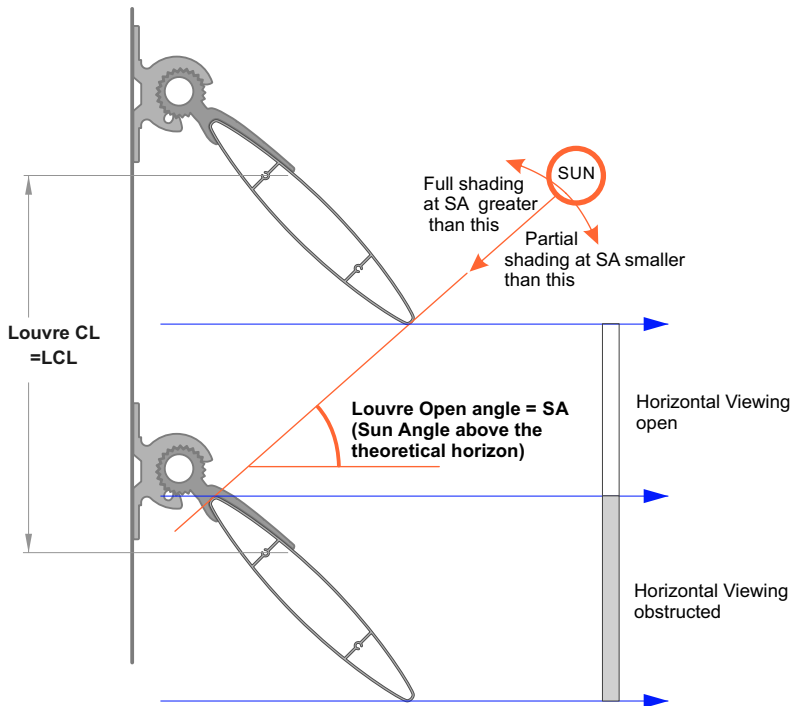

HD 250mm Louvre @45deg tilted down		
Louvre Open angle	LCL mm	% Open, Horiz view
10deg	210	15%
20deg	245	25%
30deg	280	35%
40deg	325	45%
50deg	390	55%

Unsupported span max 3.0m

Juralco Louvelite® Solar Control Systems

Horizontal and Vertical Dimension Calculations

Horizontal Dimension. Louvre Screen Size

This will always be greater than the window horizontal dimension.
This is most affected by the distance the louvre screen is mounted out from the window.
Mostly a Mid Summer Sun problem.

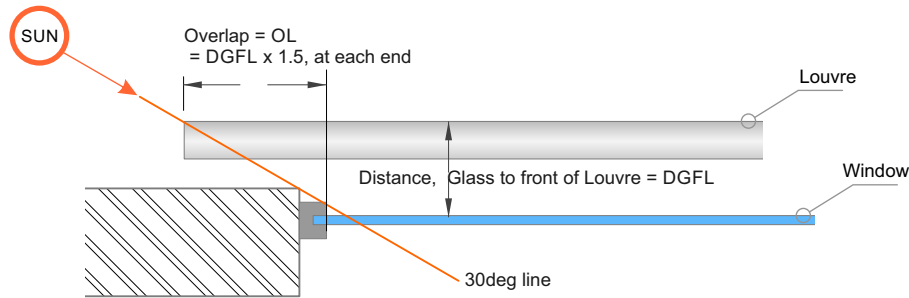

Window, Louvres Plan view

This is a compromise between early morning/late afternoon shading.
A bigger overlap can be used, say 2 or even 3 x DGFL

Vertical Dimension. Louvre Screen Size

This will mostly be greater than the window vertical dimension.
This is most affected by the distance the louvre screen is mounted out from the window.
The Topmost louvre must Block Mid Summer sun at the middle of the day

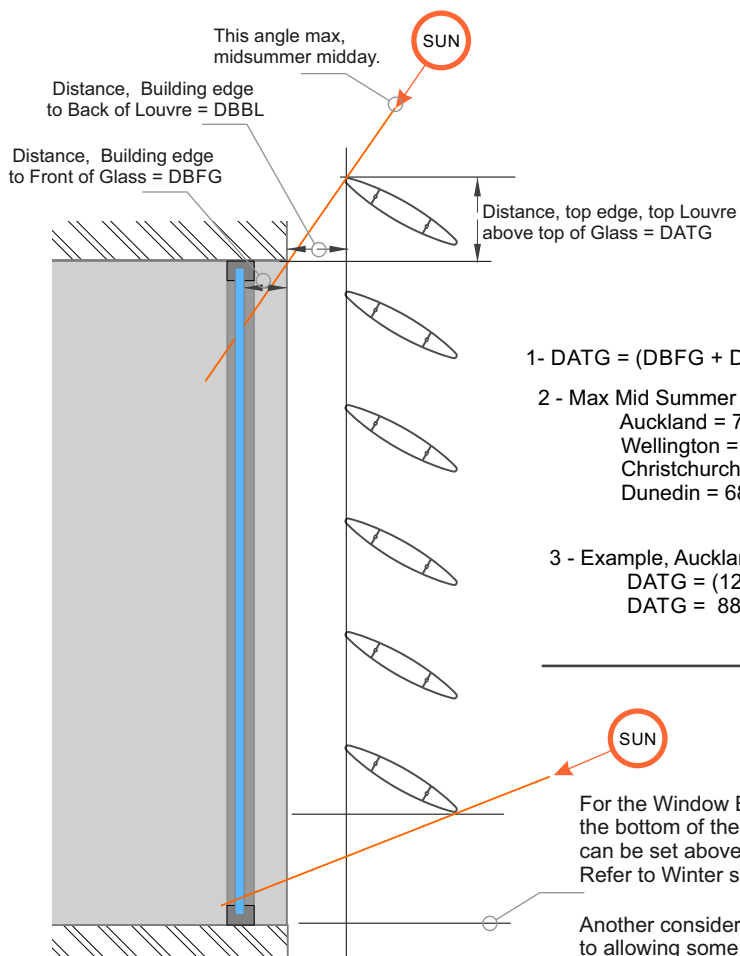

1 - $DATG = (DBFG + DBBL) \times \tan(\text{max sun angle}) \times DBBL / (DBFG + DBBL)$

- 2 - Max Mid Summer Sun Angle Elevation
 Auckland = 77 deg, (tan 77 = 4.4)
 Wellington = 73deg, (tan 73 = 3.3)
 Christchurch = 70 deg, (tan 70 = 2.85)
 Dunedin = 68deg, (tan 68 = 2.5)

3 - Example, Auckland, DBFG = 125mm, DBBL = 200mm
 $DATG = (125 + 200) \times 4.4 \times 200 / (200 + 125)$
 DATG = 880mm, Allow a small safety margin, add 100mm = 980mm

For the Window Base,
the bottom of the lowermost louvre
can be set above the bottom of the window.
Refer to Winter sun angles

Another consideration could be related
to allowing some sun ingress at low sun angles
morning/evening and mid winter day, in return
for some view.

Window, Louvres Elevation view

Juralco Louvrelite® Solar Control Systems
Wall Attach Methods

Recommended Attachment Method - Baseplates/Packers to a Building surface

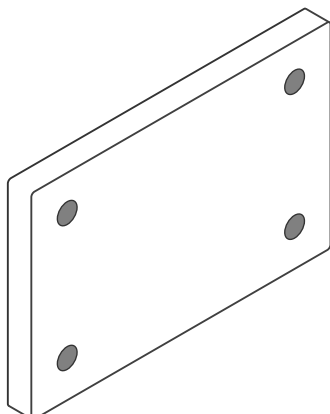

- 1 - Metal Plate Supporting Louvre Structure
(Back side view)

Pre-drill holes for attachment screws into the building structure.

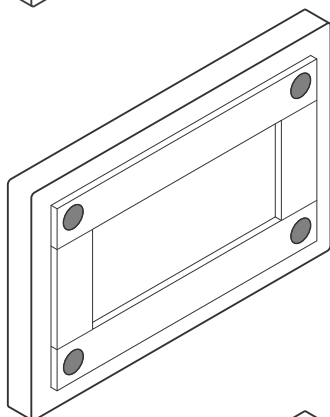

- 2 - Apply 25mm x 3mm Double sided foam tape to base plate rear, leaving about a 10mm gap to the edge. All holes to be covered by tape.
(Back side view)

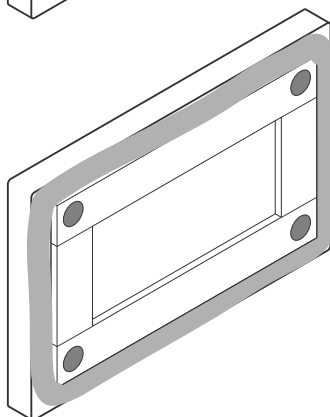

- 3 - Apply a bead of sealant to the back/outside of the base plate.
(Back side view)

- 4 - Apply Sika Supagrip 2hr to pre drilled holes
Apply base plate to Wall
Attach with appropriate screws.
Tighten. Clean up.



Juralco LouvreLite® Solar Control Systems
Wall Attach Methods

Weatherboards - Direct Fix - Method 1

You will need an engineer to confirm Structure/BasePlate/Fixing Details

Sectional Elevation Views

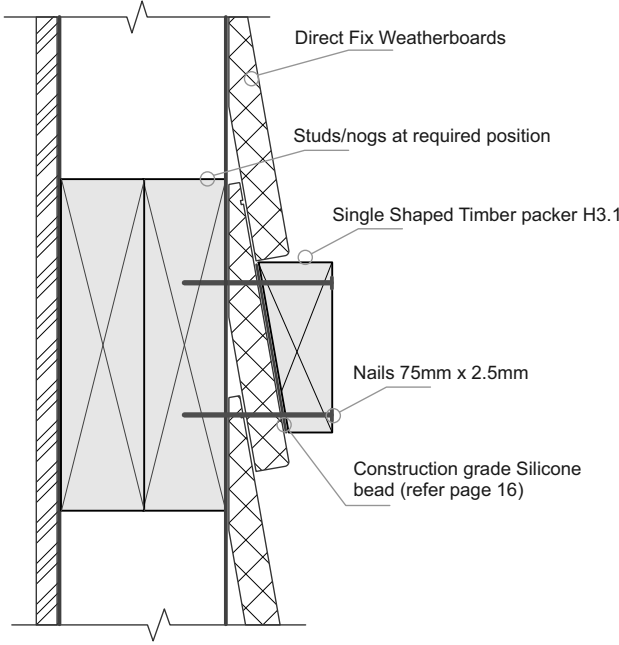

Stage 1 - Attach Timber Packer

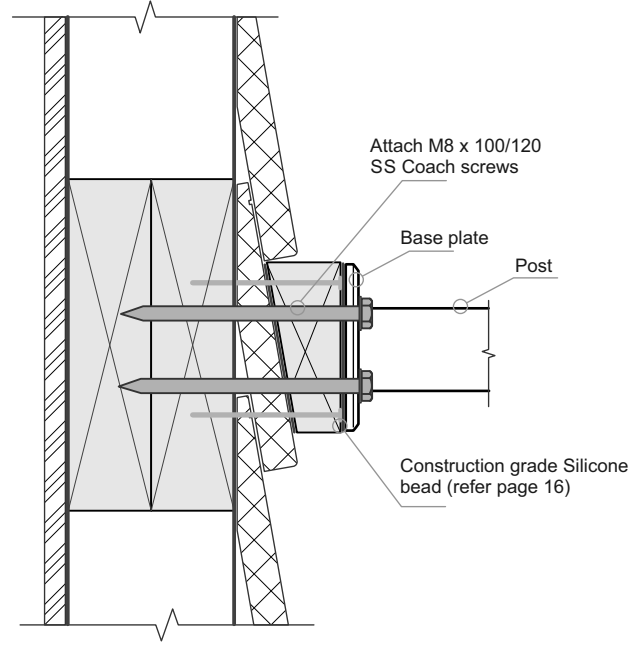

**Stage 2 - Attach Louvre support Baseplate
 (min 24 hrs silicone set off)**

Plan View

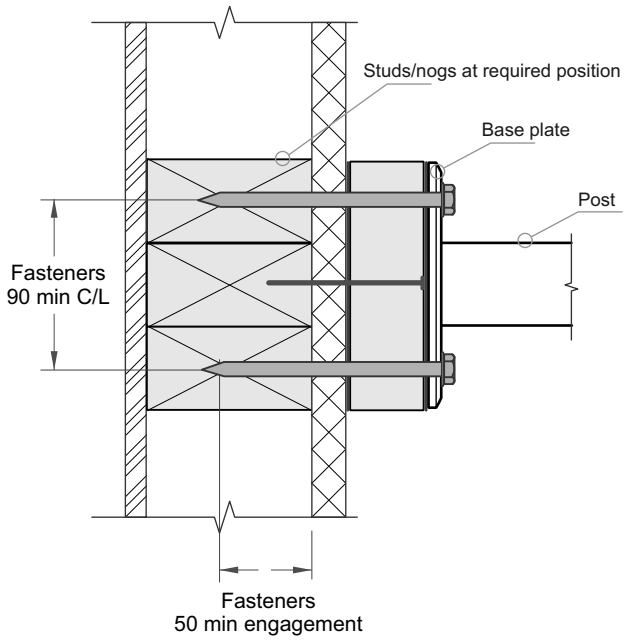

Typical Timber Packer

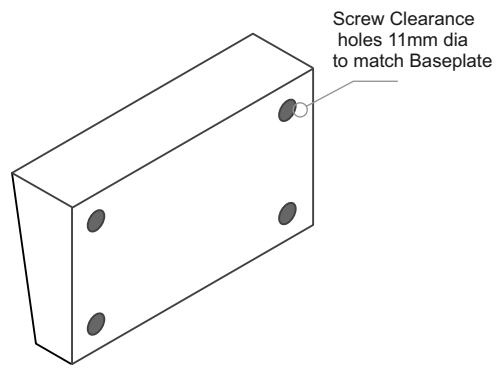

Juralco Louvre[®] Solar Control Systems
Wall Attach Methods

Weatherboards - Direct Fix - Method 2

You will need an engineer to confirm Structure/BasePlate/Fixing Details

Sectional Elevation Views

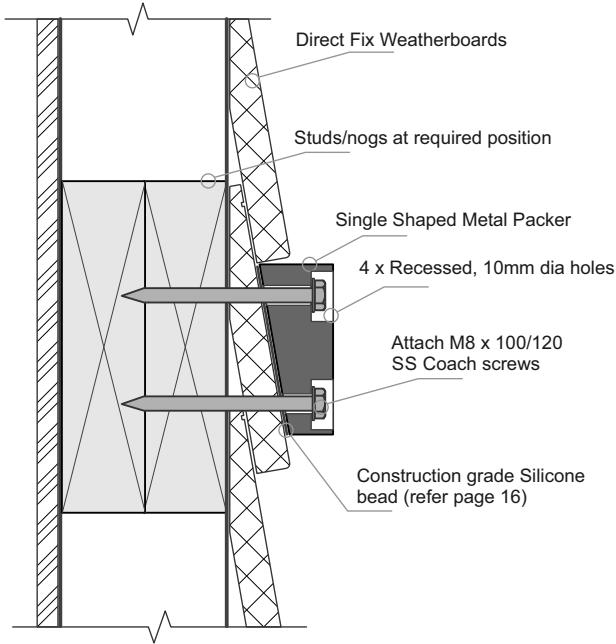

Stage 1 - Attach Metal Packer

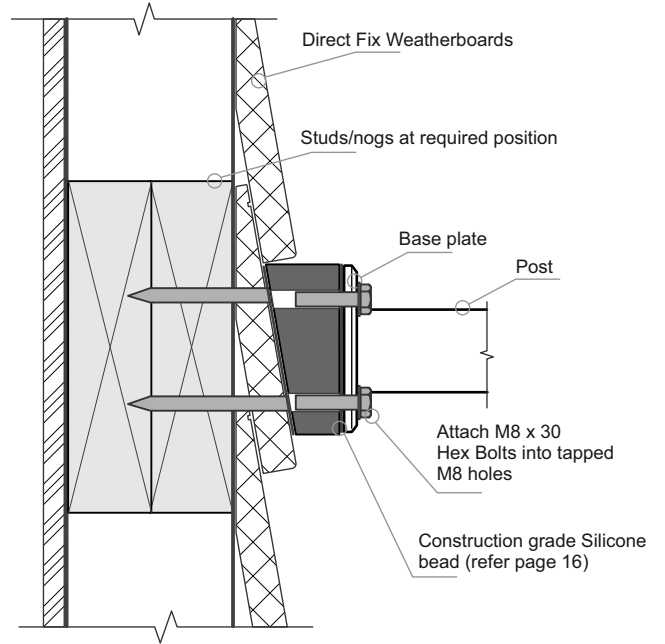

Stage 2 - Attach Louvre support Baseplate

Plan View

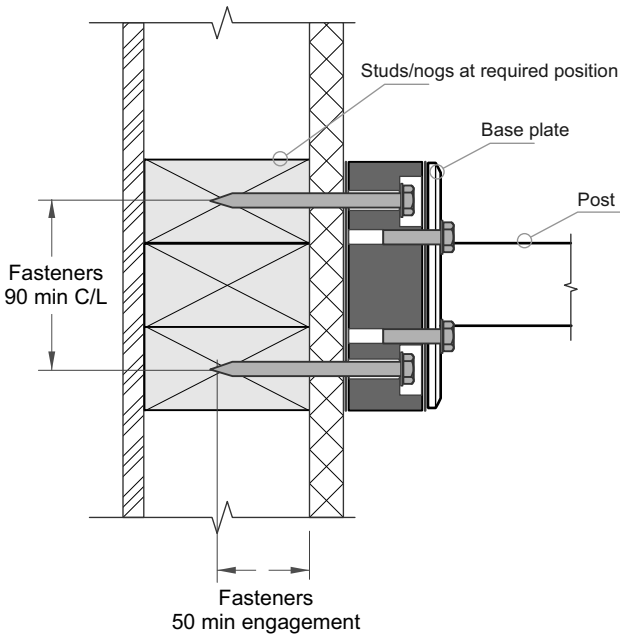

Typical Metal Packer

Custom Machined Metal Packer

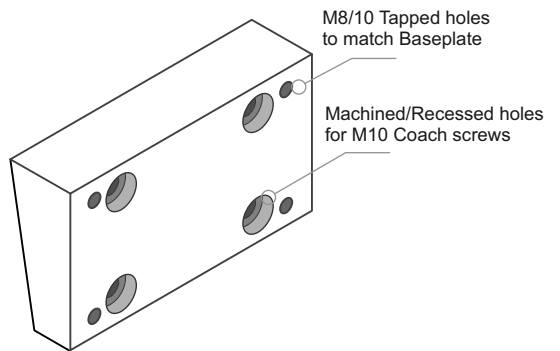

Juralco Louvrelite® Solar Control Systems
Wall Attach Methods

Weatherboards - Vented Cavity - Method 1

You will need an engineer to confirm Structure/BasePlate/Fixing Details

Sectional Elevation Views

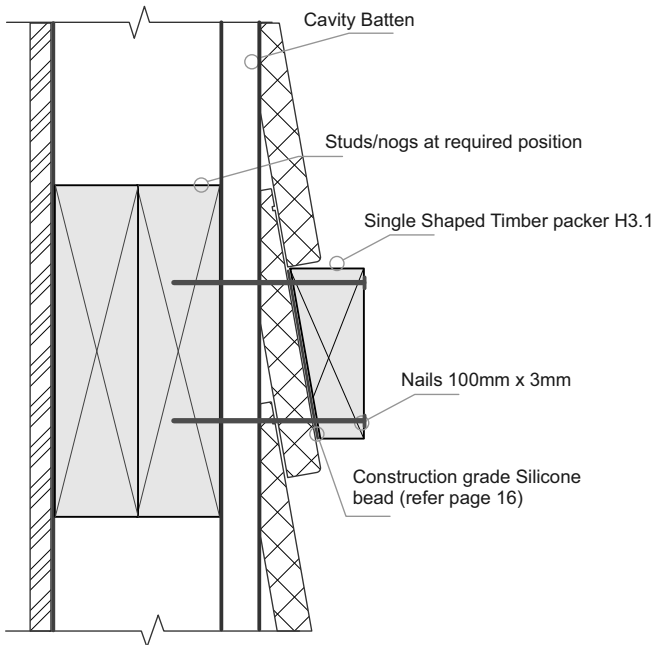

Stage 1 - Attach Timber Packer

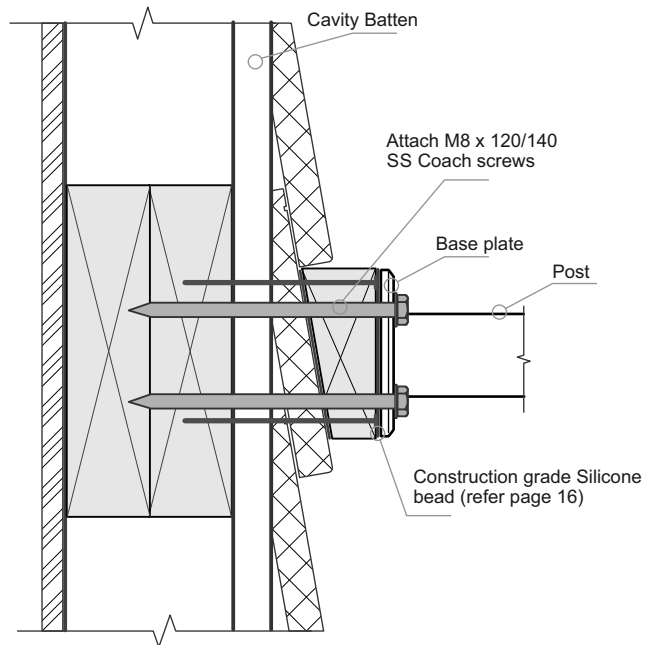

Stage 2 - Attach Louvre support Baseplate (min 24 hrs silicone set off)

Plan View

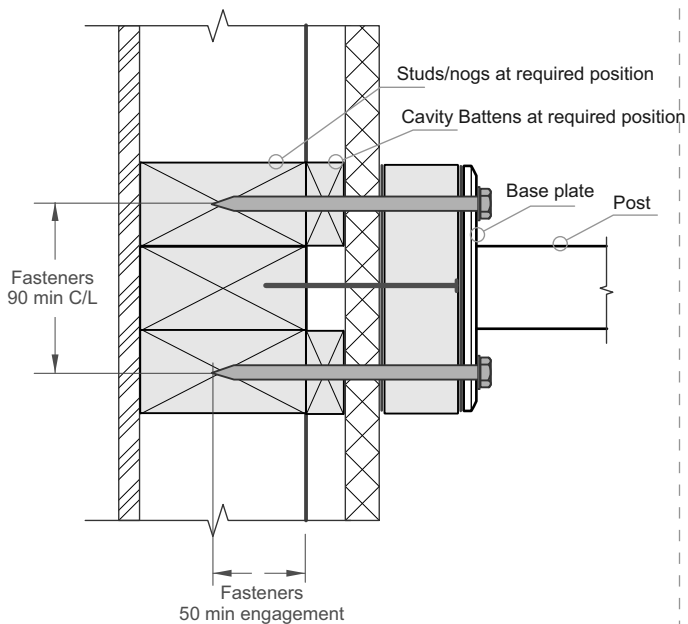

Plan View

Typical Timber Packer

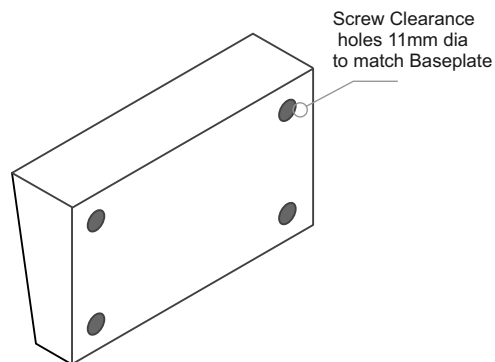

Juralco Louvre[®] Solar Control Systems
Wall Attach Methods

Weatherboards - Vented Cavity - Method 2

You will need an engineer to confirm Structure/BasePlate/Fixing Details

Sectional Elevation Views

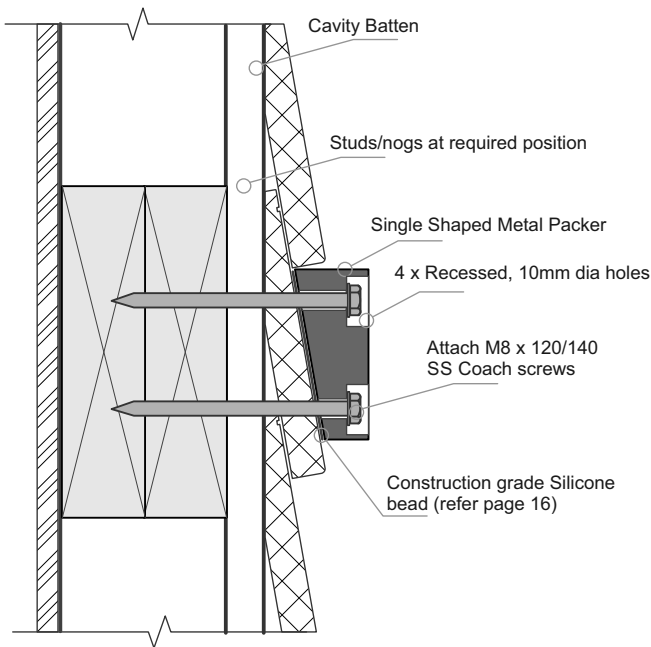

Stage 1 - Attach Metal Packer

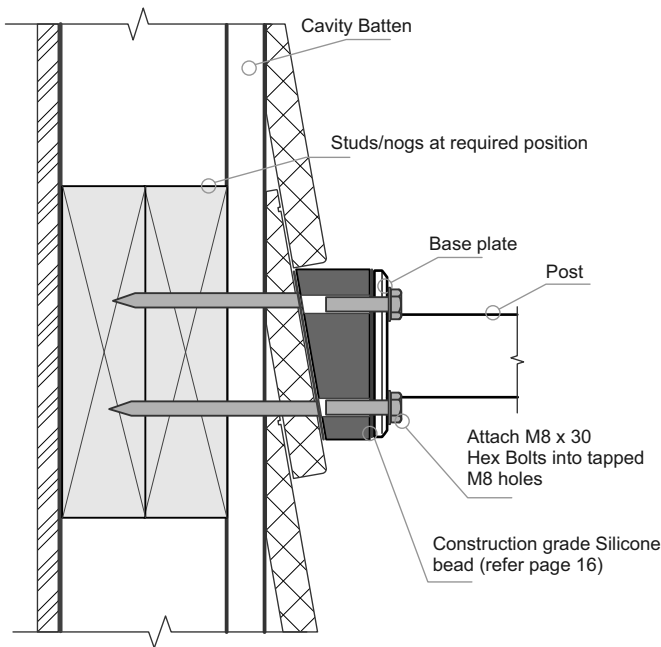

Stage 2 - Attach Louvre support Baseplate

Plan View

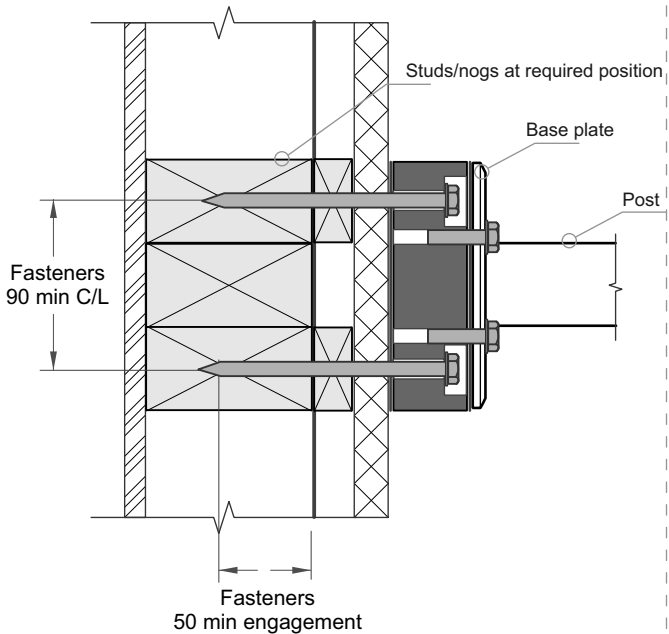

Typical Metal Packer

Custom Machined Metal Packer

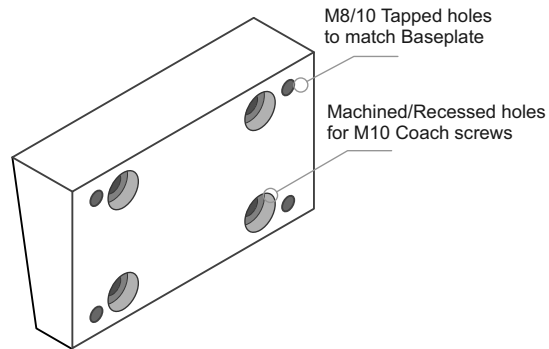

Juralco Louvrelite® Solar Control Systems
Wall Attach Methods

Monolithic Cladding - Direct Fix

You will need an engineer to confirm Structure/BasePlate/Fixing Details

Sectional Elevation View

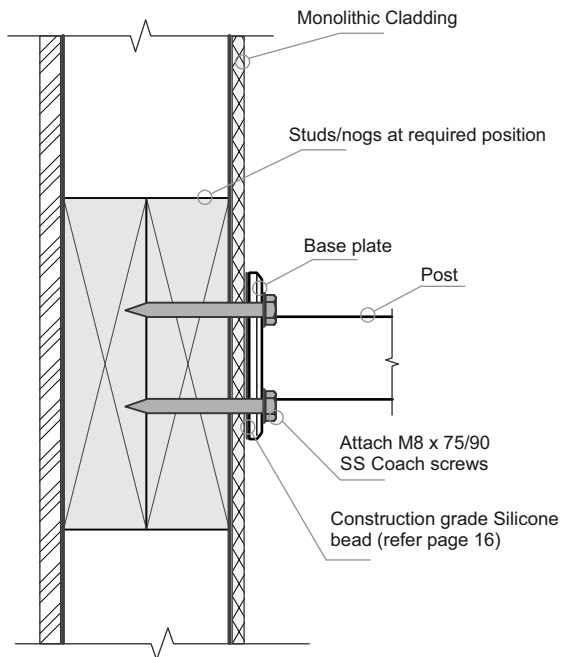

Plan View

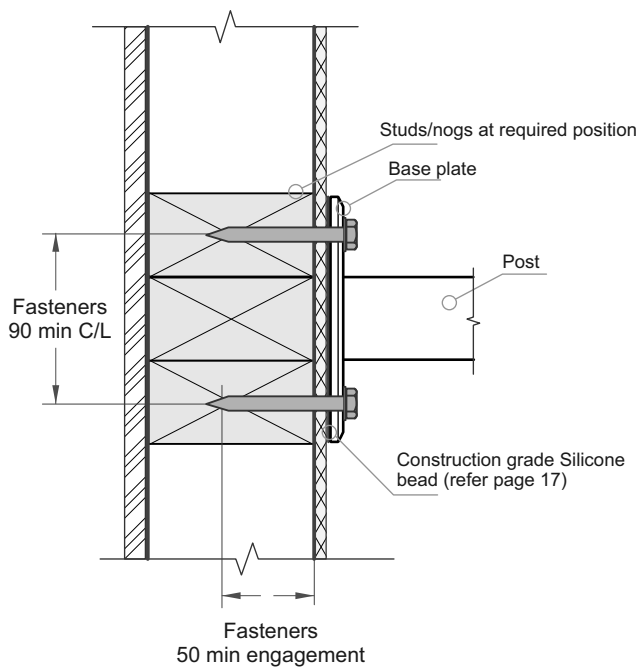

Juralco Louvrelite® Solar Control Systems
Wall Attach Methods

Monolithic Cladding - Vented Cavity

You will need an engineer to confirm Structure/BasePlate/Fixing Details

Sectional Elevation View

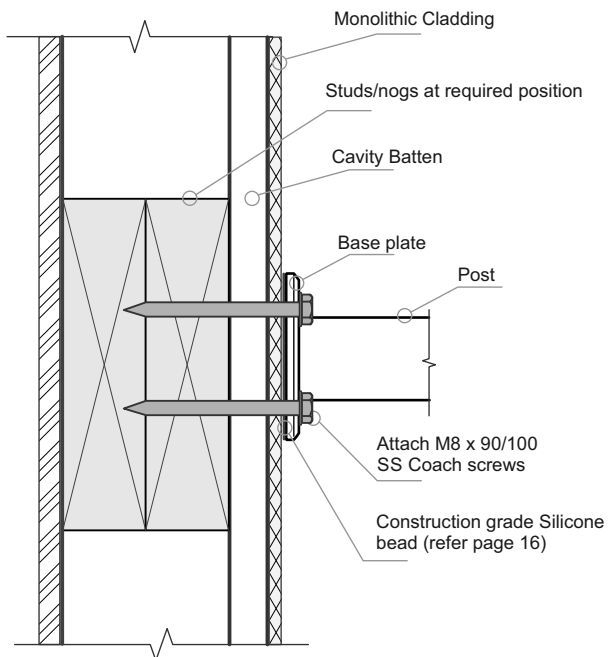

Plan View

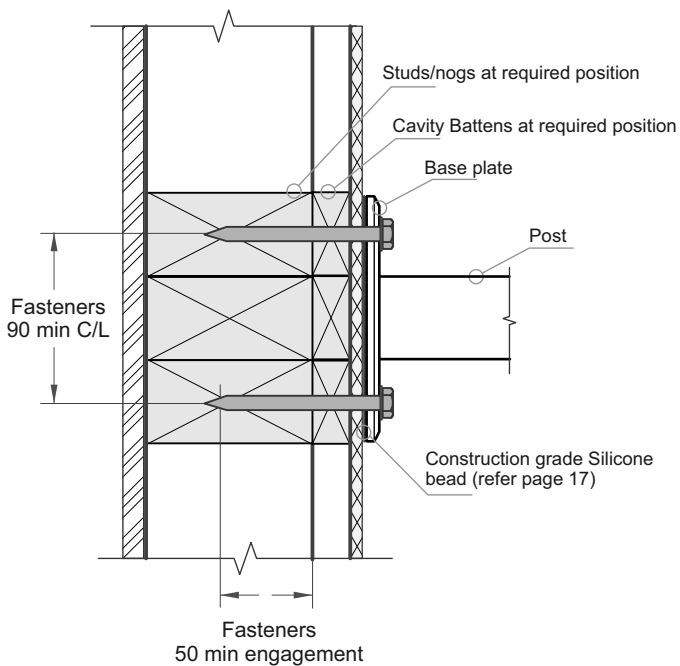

Juralco Louvre[®] Solar Control Systems
Wall Attach Methods

Brick Veneer - Vented Cavity

You will need an engineer to confirm Structure/BasePlate/Fixing Details

Sectional Elevation View

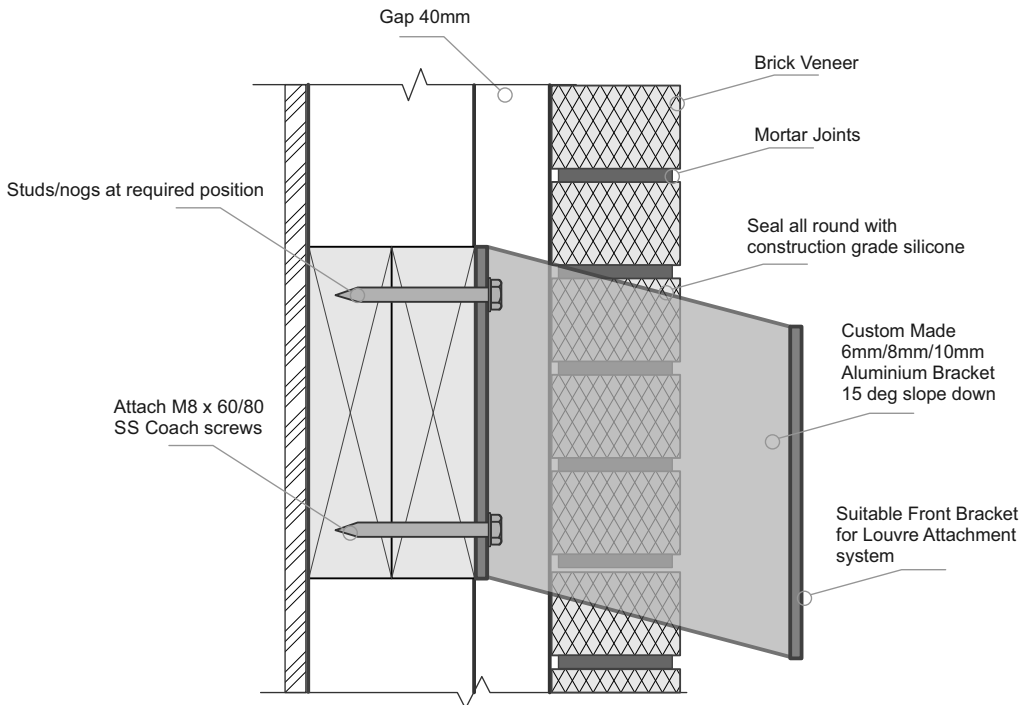

Plan View

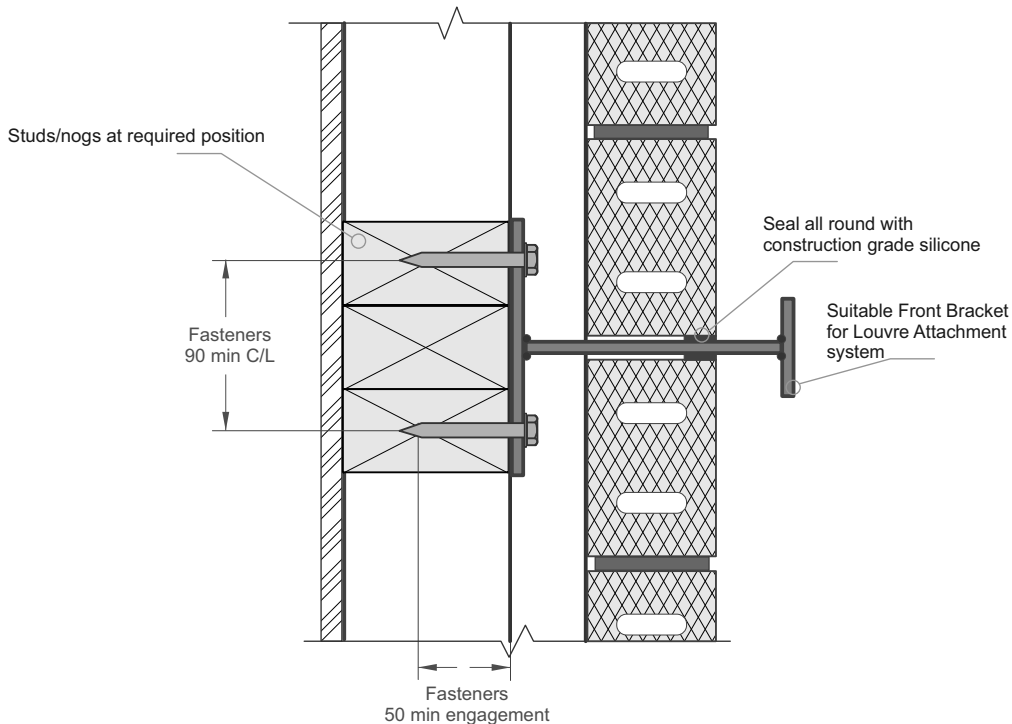

Juralco Louvrelite® Solar Control Systems
Wall Attach Methods

Concrete Cladding

You will need an engineer to confirm Structure/BasePlate/Fixing Details

Sectional Elevation View

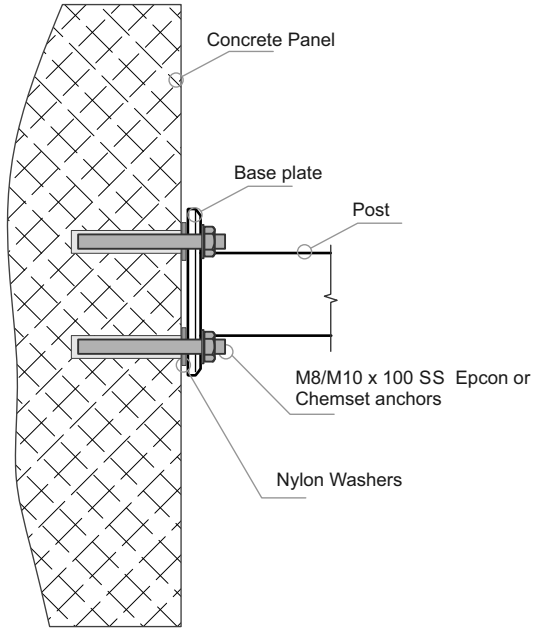

Plan View

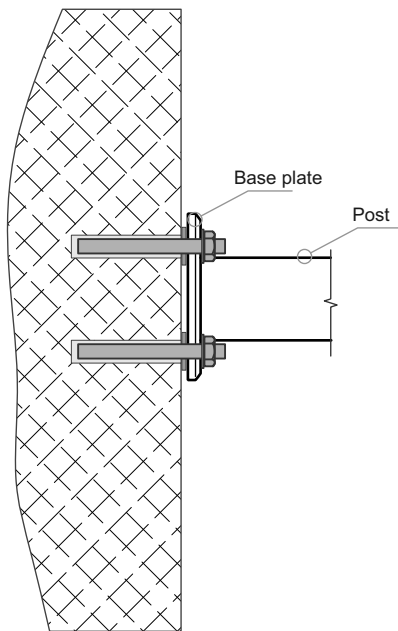

**Juralco Louvelite® Solar Control Systems
Wall Attach Methods**

Profiled Metal Cladding - Vented Cavity

You will need an engineer to confirm Structure/BasePlate/Fixing Details

Sectional Elevation View

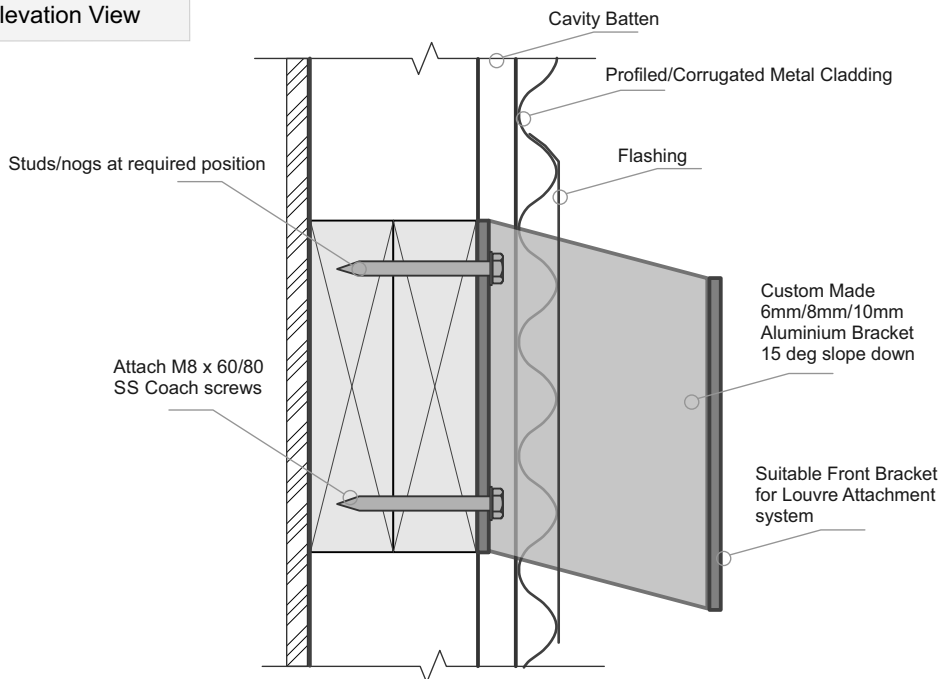

Plan View

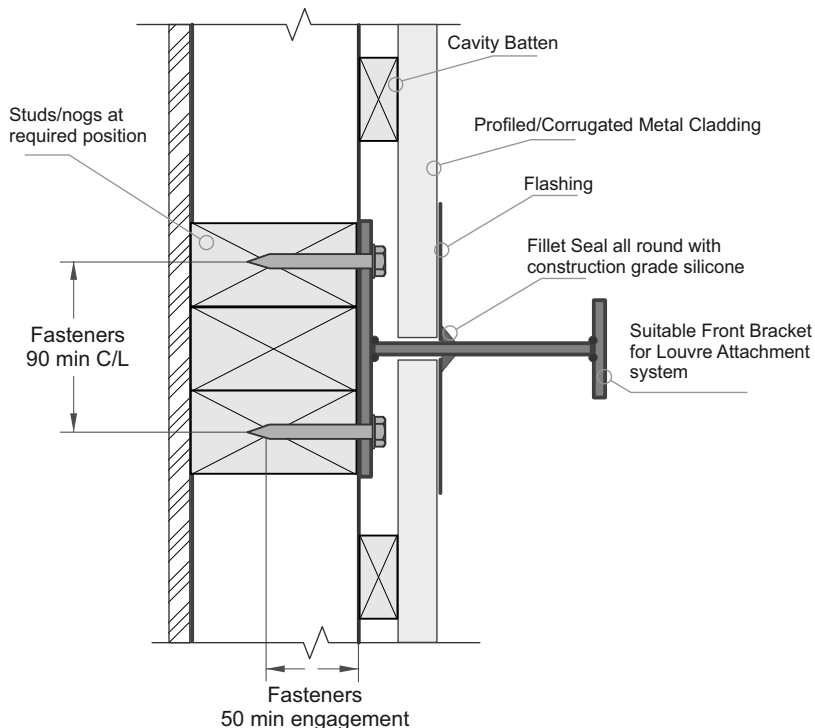

Typical Flashing

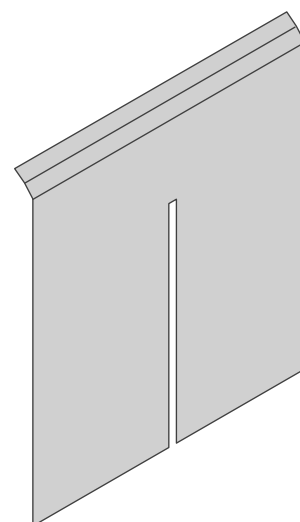

Juralco LouvreLite® Solar Control Systems
Wall Attach Methods

Metal Panel Cladding - Vented Cavity

You will need an engineer to confirm Structure/BasePlate/Fixing Details

Sectional Elevation View

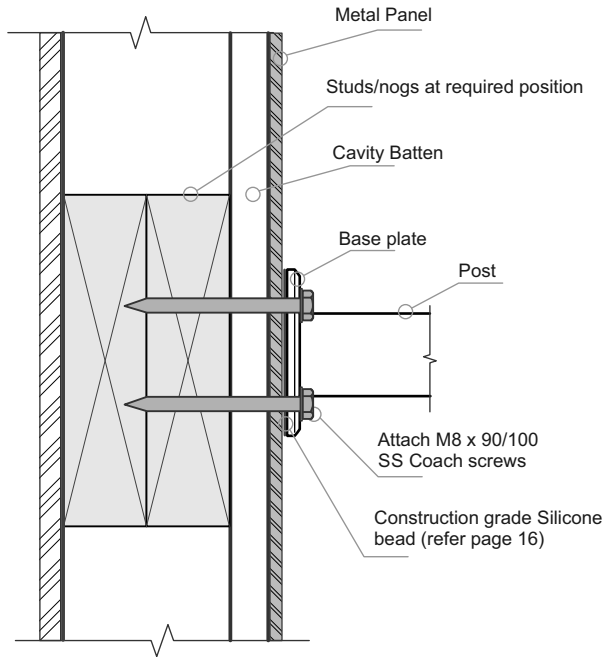

Plan View

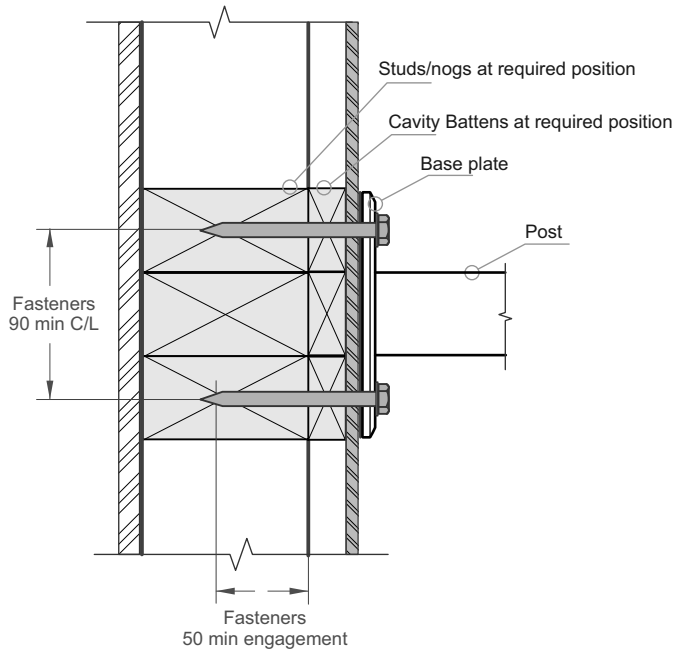

Juralco LouvreLite® Solar Control Systems
Wall Attach Methods

Attach LV 2240 Directly to a Wall

You will need an engineer to confirm Structure/BasePlate/Fixing Details

Sectional Elevation View

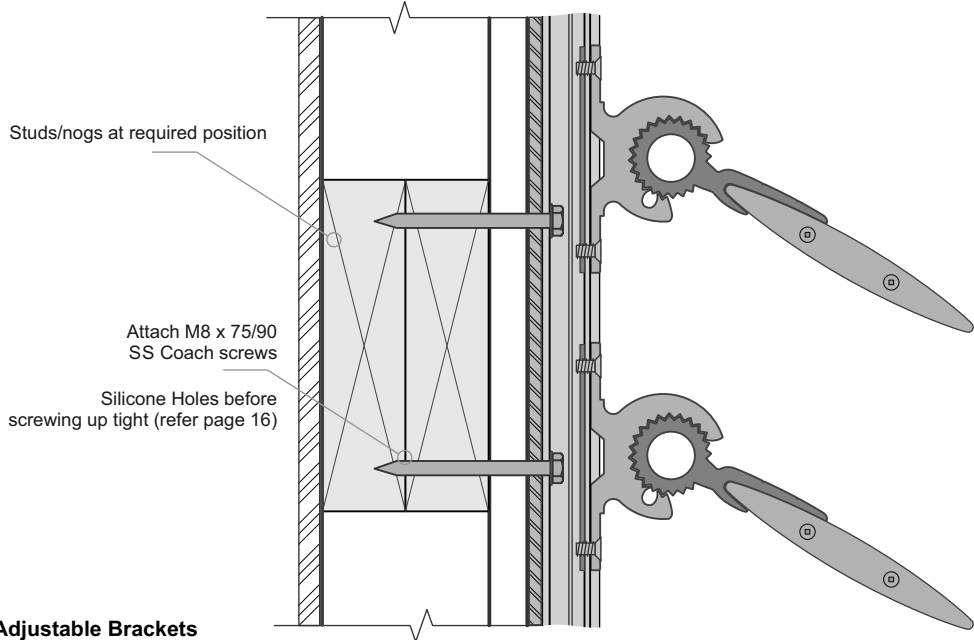

Note : The Louvre Adjustable Brackets can be mounted to the Topside or Underside of the louvre.

Topside mounts shown. Normal mount if directly over windows

Plan View

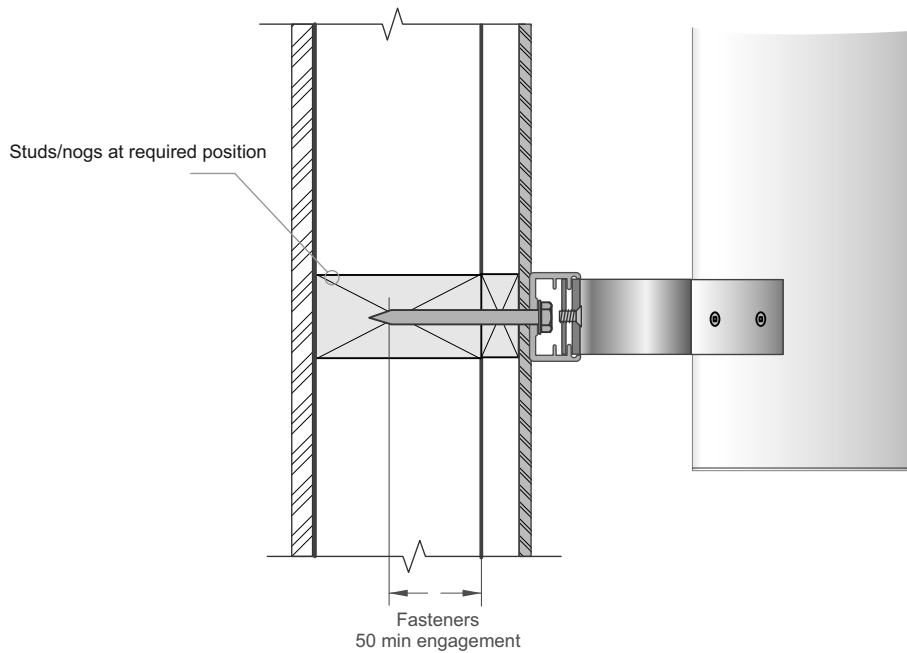

Juralco LouvreLite® Solar Control Systems
Wall Attach Methods

Attach LV 2240 Directly to a Window Mullion

You will need an engineer to confirm Structure/BasePlate/Fixing Details

Sectional Elevation View
Typical Shop Front Mullion

Typical Window Mullion - Shop Front Type
 All fasteners at 400mm max spacing

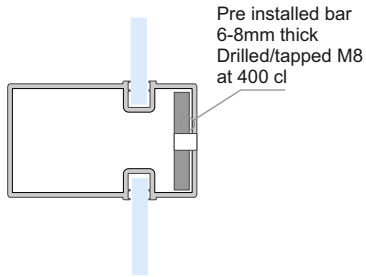

Typical Window Mullion
 Shop Front

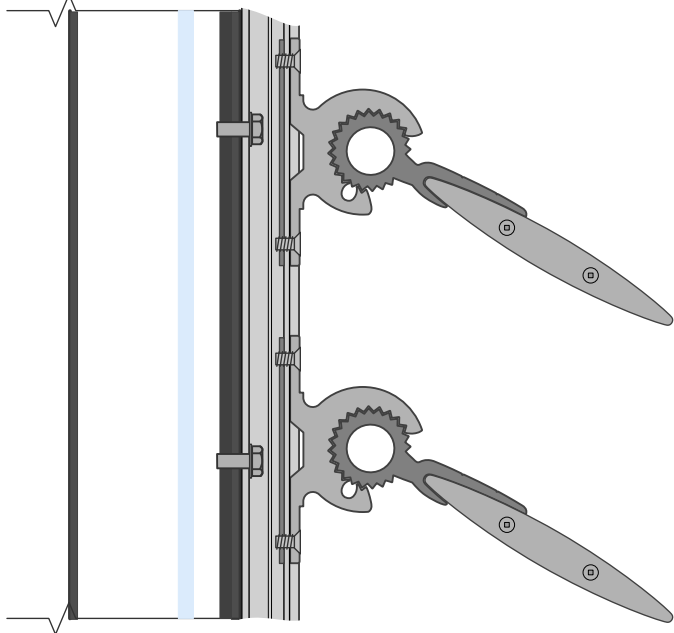

Note : The Louvre Adjustable Brackets can be mounted to the Topside or Underside of the louvre.

Topside mounts shown. Normal mount if directly over windows

Coordination with the Glazing manufacturer will be needed at the Glazing section design/manufacture stage

Plan View

Typical Window Mullion - Shop Front Type
 All fasteners at 400mm max spacing

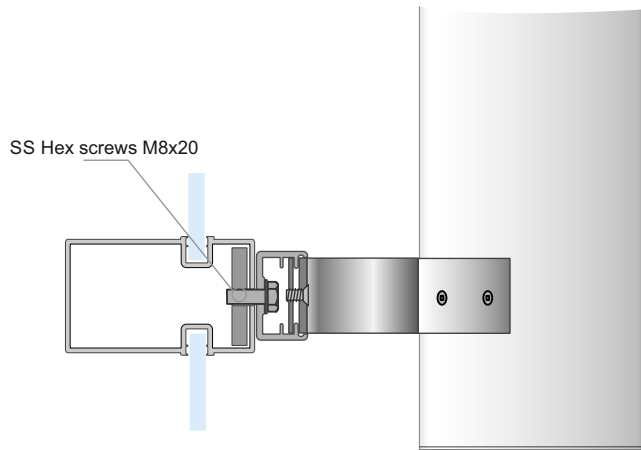

Coordination with the Glazing manufacturer will be needed at the Glazing section design/manufacture stage

Juralco Louvelite® Solar Control Systems

Wall Attach Methods

Attach LV 2240 Directly to a Window Mullion

You will need an engineer to confirm Structure/BasePlate/Fixing Details

Sectional Elevation View
Typical Curtain Wall Mullion

Typical Window Mullion - Curtain Wall Type
All fasteners at 400mm max spacing

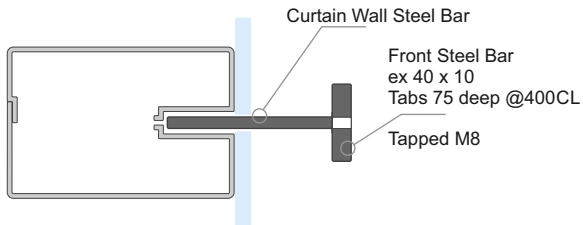

Typical Curtain Wall Mullion

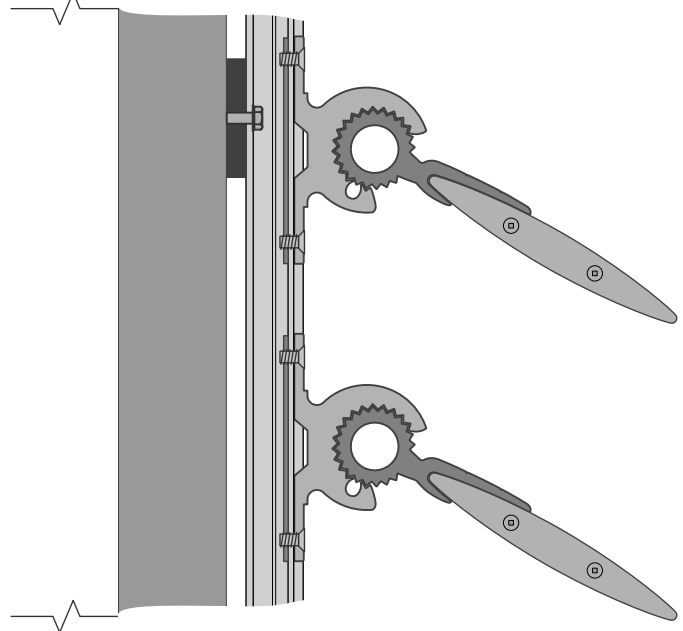

Note : The Louvre Adjustable Brackets can be mounted to the Topside or Underside of the louvre.

Topside mounts shown. Normal mount if directly over windows

Coordination with the Glazing manufacturer will be needed at the Glazing section design/manufacture stage

Plan View

Typical Window Mullion - Curtain Wall Type
All fasteners at 400mm max spacing

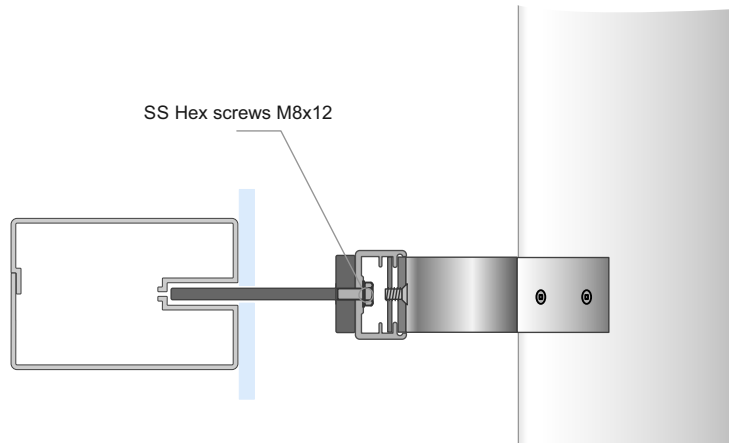

Coordination with the Glazing manufacturer will be needed at the Glazing section design/manufacture stage

Auckland and top half of NI

Sun above
 a flat Horizon

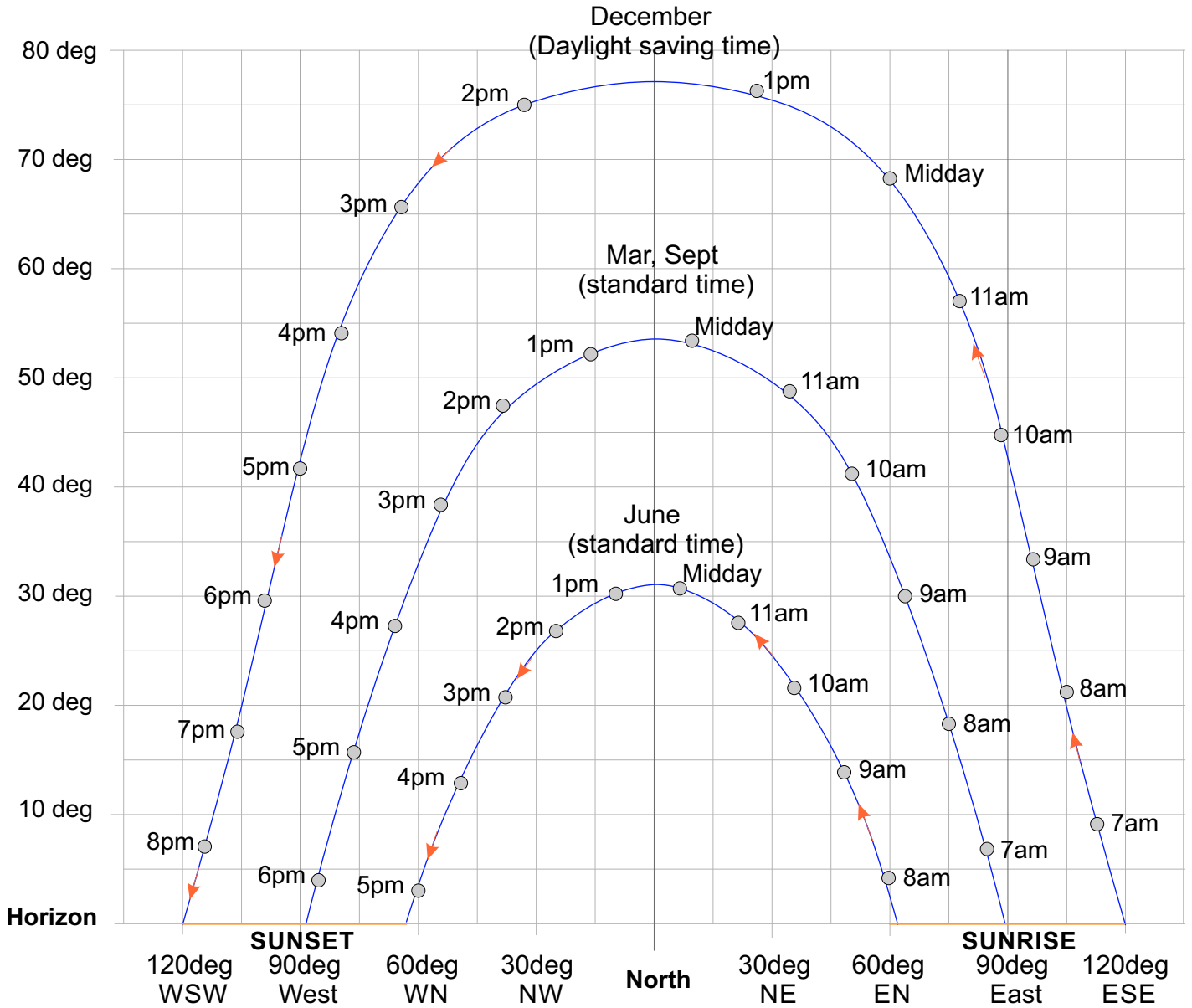

Wellington and bottom half of NI

Sun above
 a flat Horizon

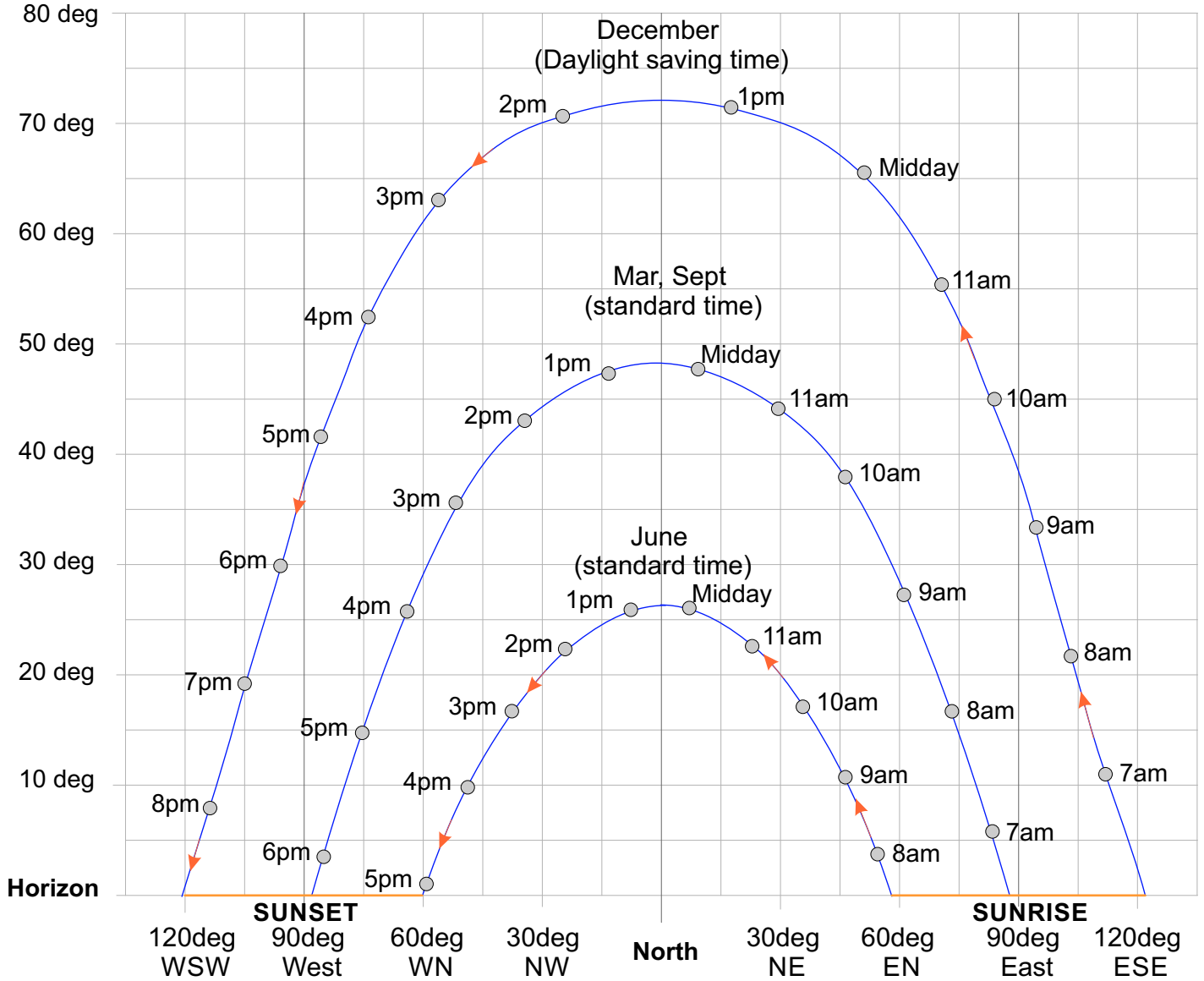

Christchurch and top half of SI

Sun above
 a flat Horizon

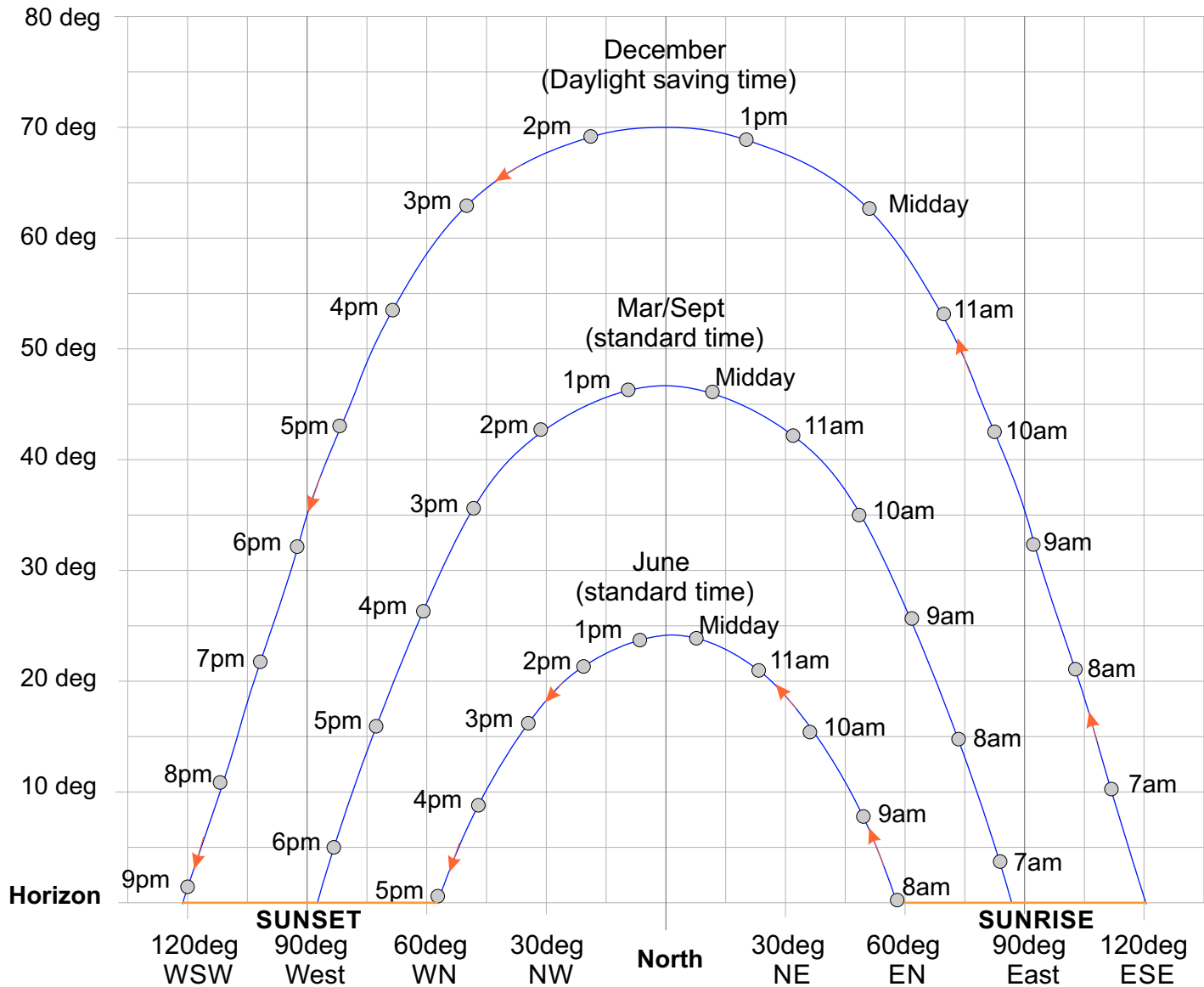

Dunedin and bottom half of SI

Sun above
 a flat Horizon

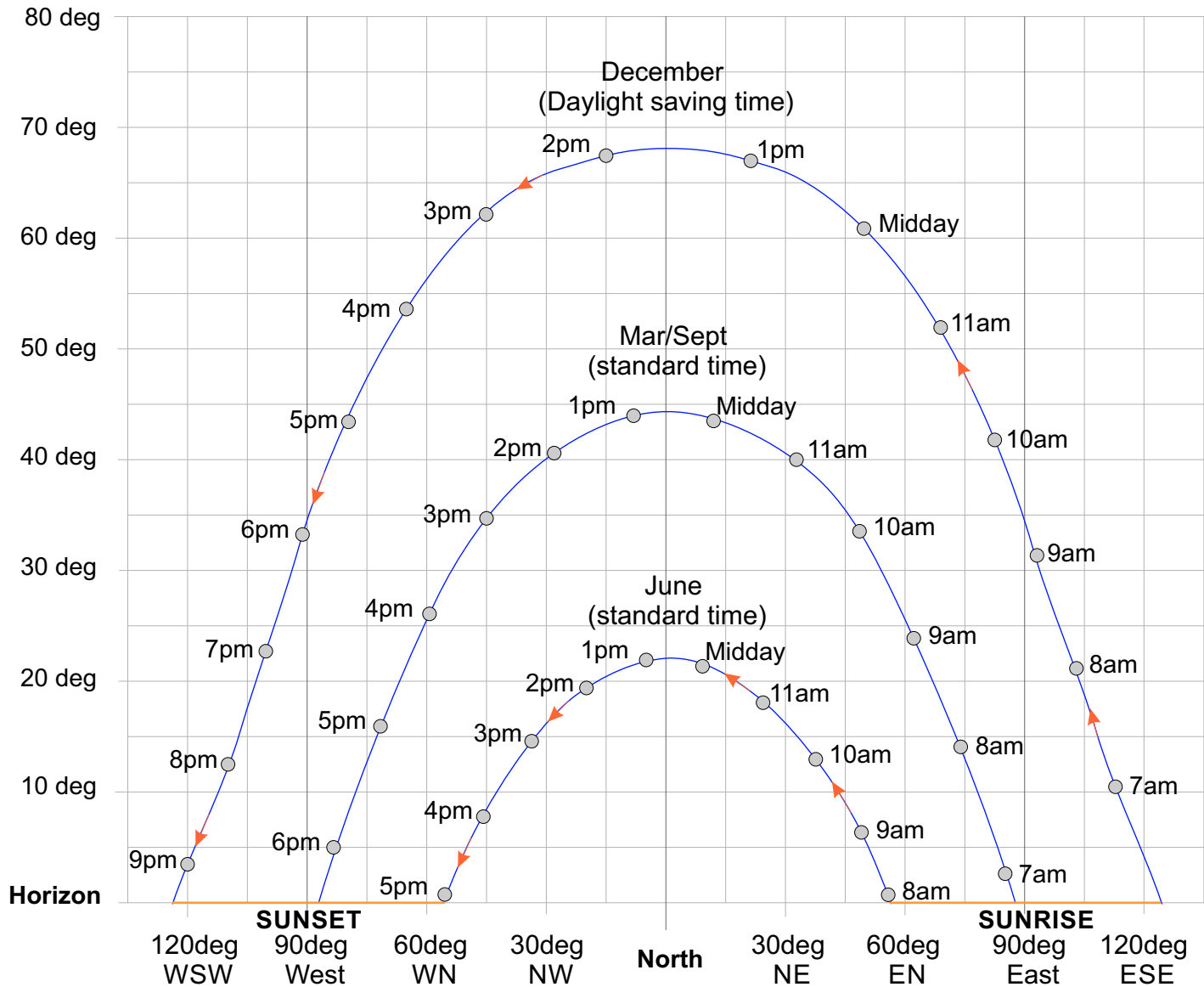

Juralco Louvelite® Solar Control Systems

Rectangular Louvre 150 x 50

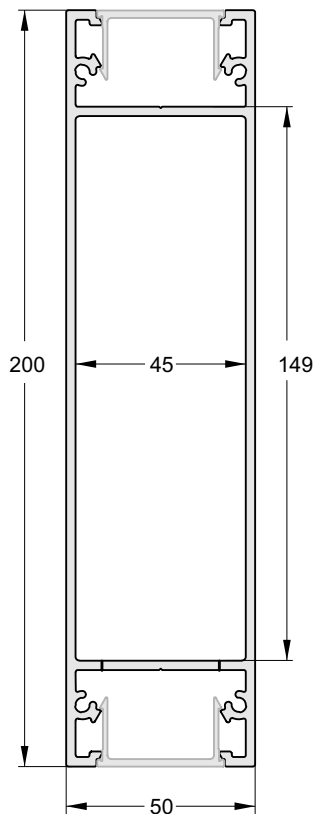

JLV/2638/5.8
200x50mm
Rectangular Louvre

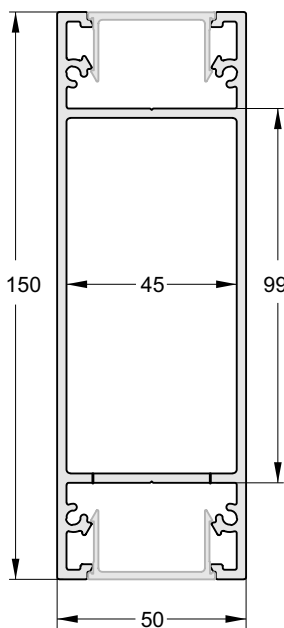

JLV/2635/5.8
150x50mm
Rectangular Louvre

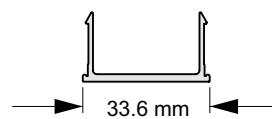

JLV/2630/5.8
Infill Clip

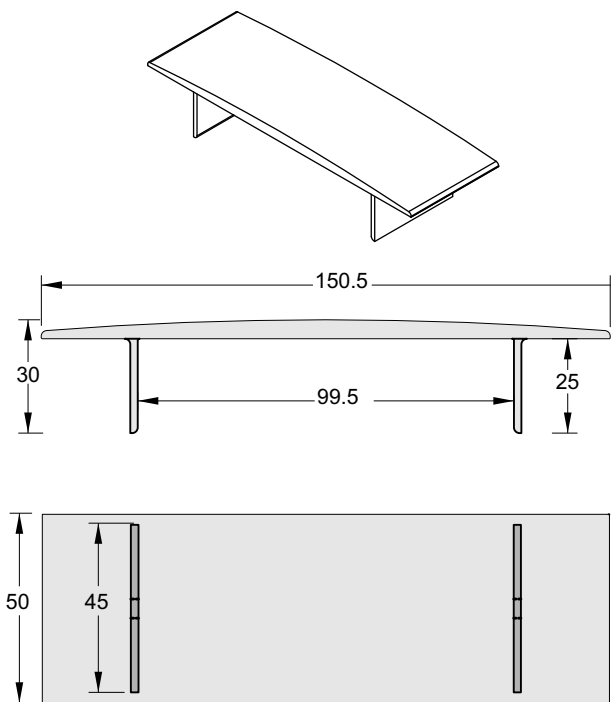

JLV/R150TC
150x50mm
Rectangular Louvre
Top Cap

Note - No 200x50 Top Cap
Use End Caps both Ends

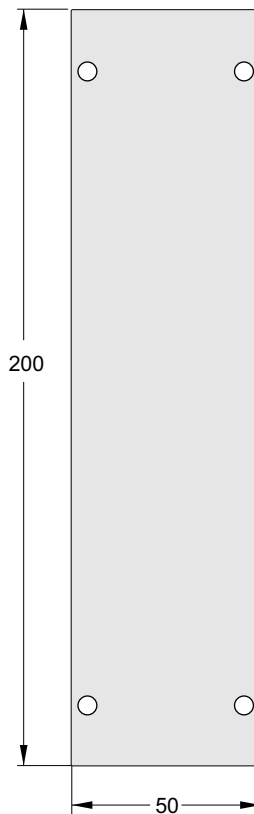

JLV/R200EC
200x50mm
Rectangular Louvre
End Cap

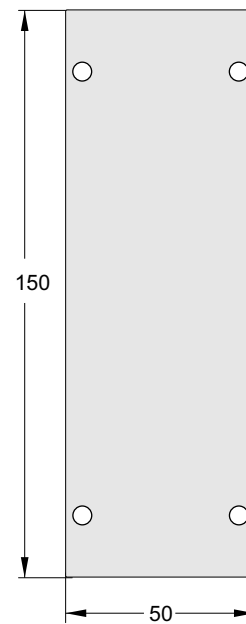

JLV/R150EC
150x50mm
Rectangular Louvre
End Cap

Juralco Louvelite® Solar Control Systems
Rectangular Louvre 150 x 50

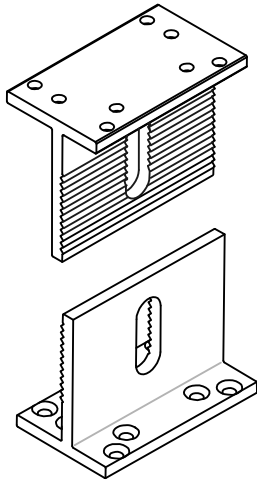

JLV/L30
 150 Louvre T Bracket
 (2 x required)

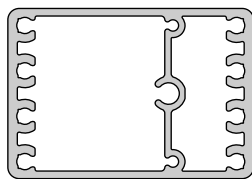
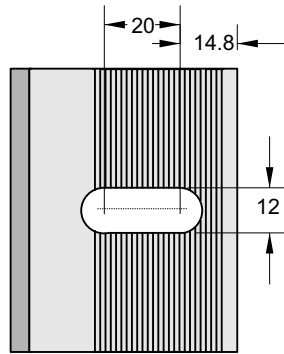
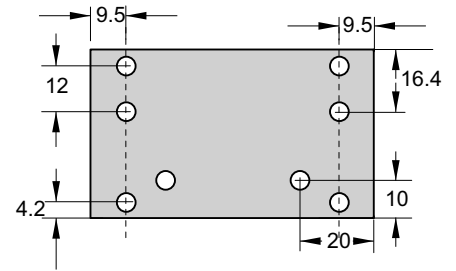
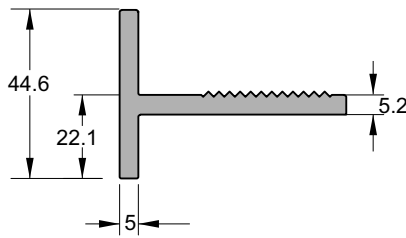
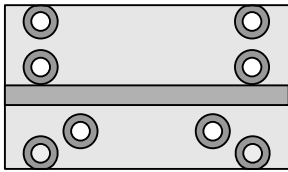
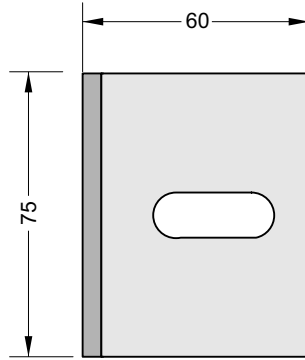

EDGE TOP FIX POST
 JEB/207/5
 45mm x 65mm

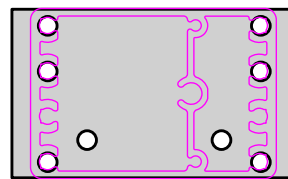

Edge Top Fix Post
 attached to adjustable
 Louvre T Bracket

Juralco LouvreLite® Solar Control Systems
Rectangular Louvre 150 x 50

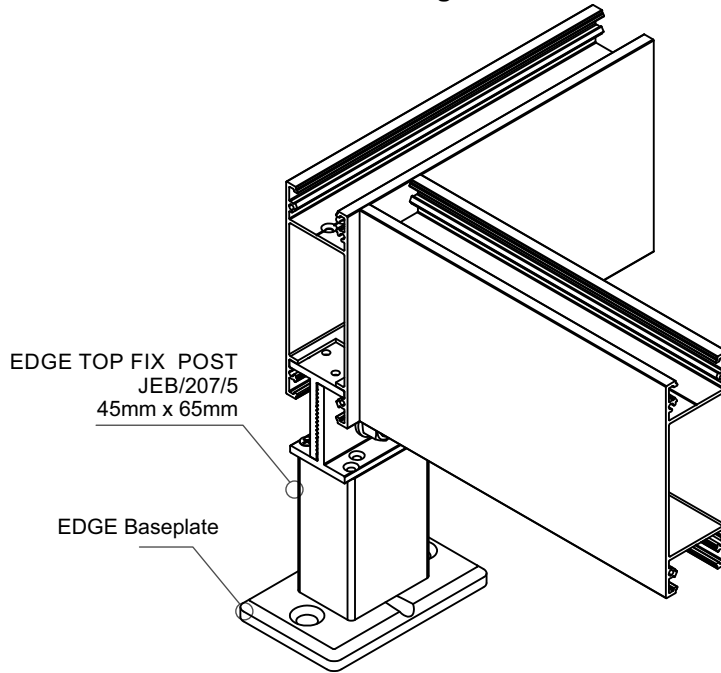

150 Louvre Adjustable T Bracket - Assembly

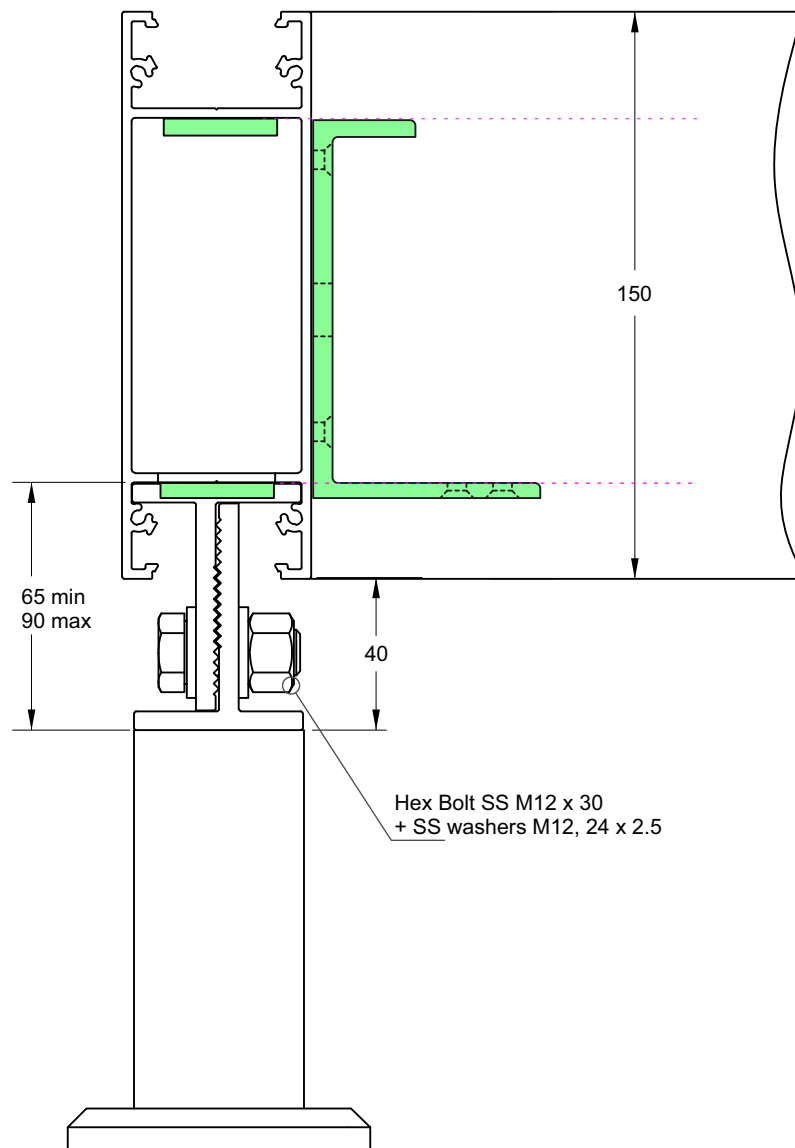

Juralco Louvrelite® Solar Control Systems
 Rectangular Louvre 150 x 50

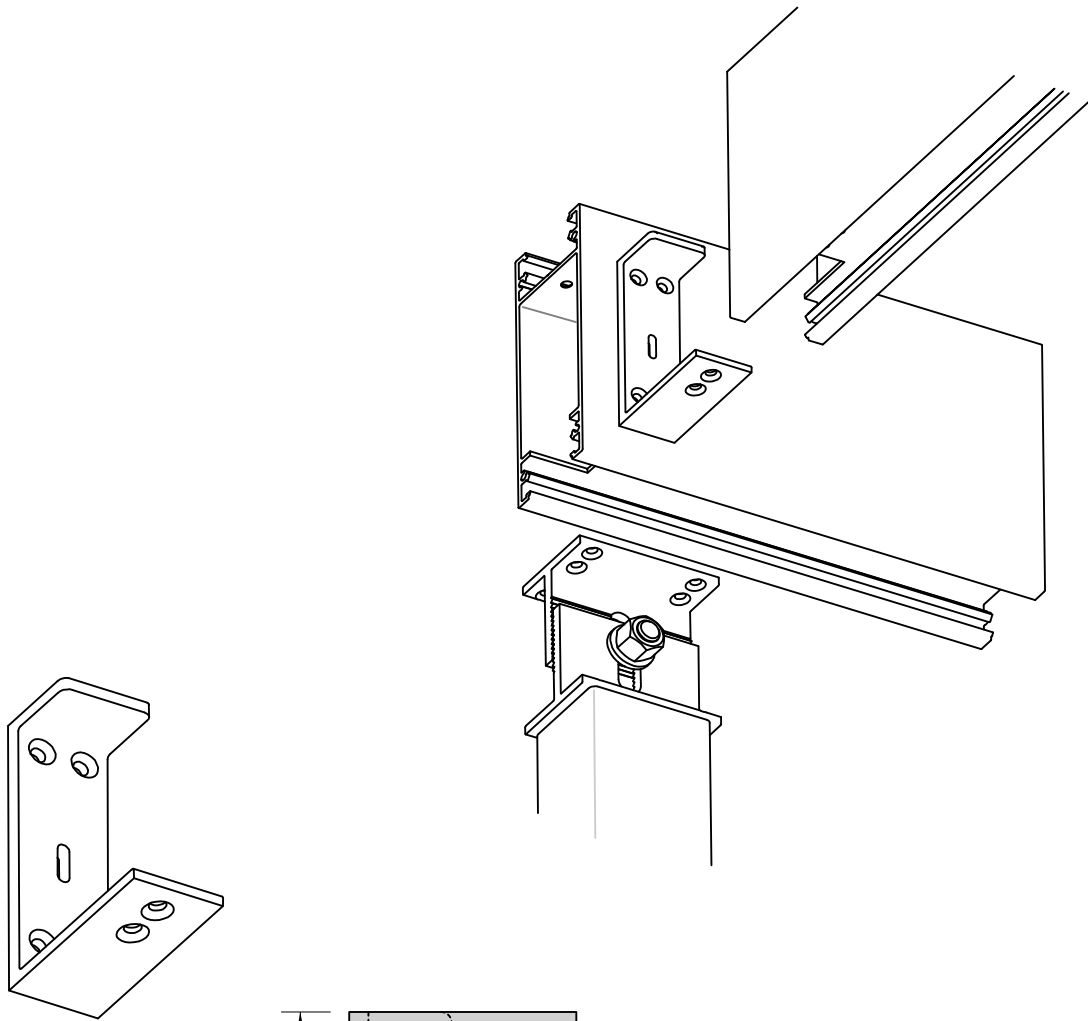

JLV/L31
 150 Louvre End Bracket
 (2 x required)

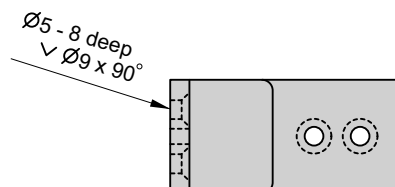
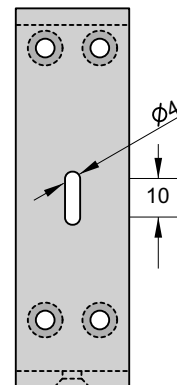
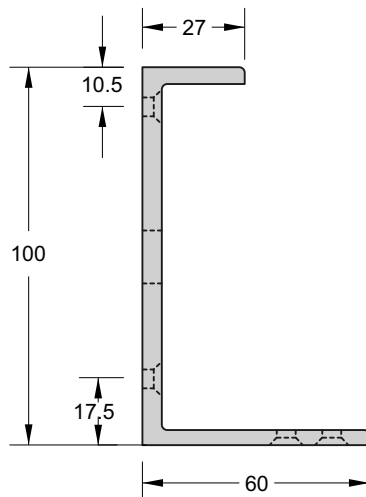
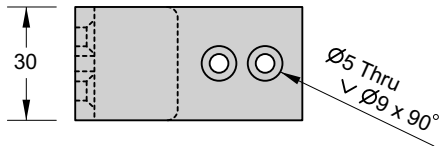

Juralco Louvrelite® Solar Control Systems
Rectangular Louvre 150 x 50

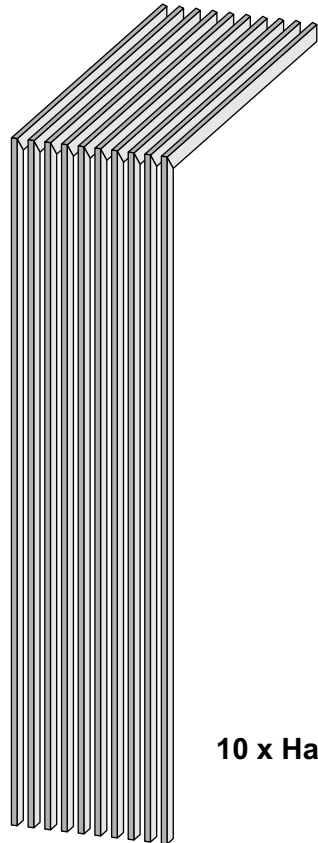
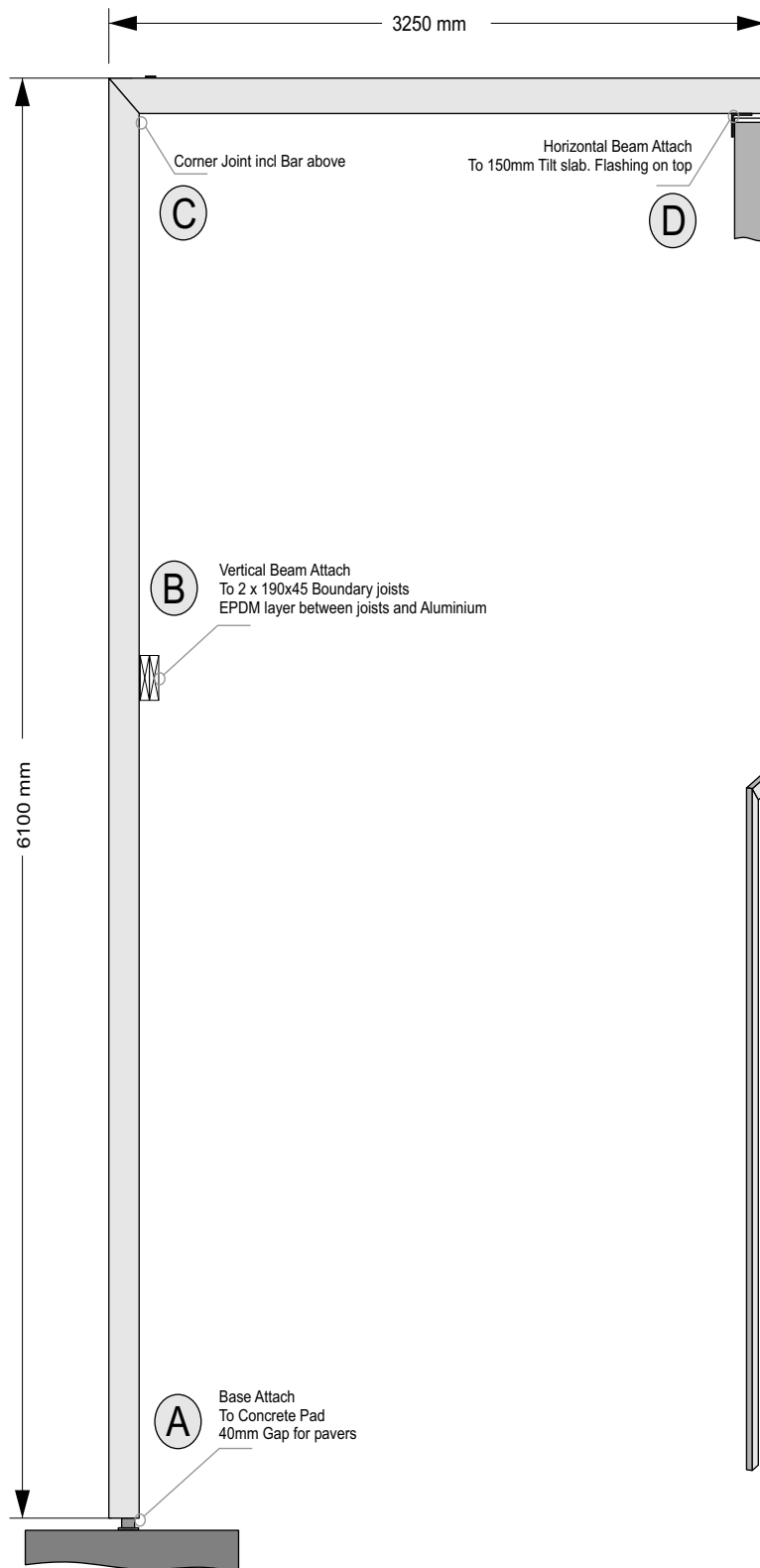

10 x Half Bridges

- With 95mm Gaps Overall width = 1355mm
- Single vertical section weighs 23kg
- Single horizontal section weighs 12kg
- ie total weight of structure is 350kg

Juralco Louvrelite® Solar Control Systems
Rectangular Louvre 150 x 50

A Base Attach. To Concrete Pad



Pergola Extrusion
150mm x 50mm

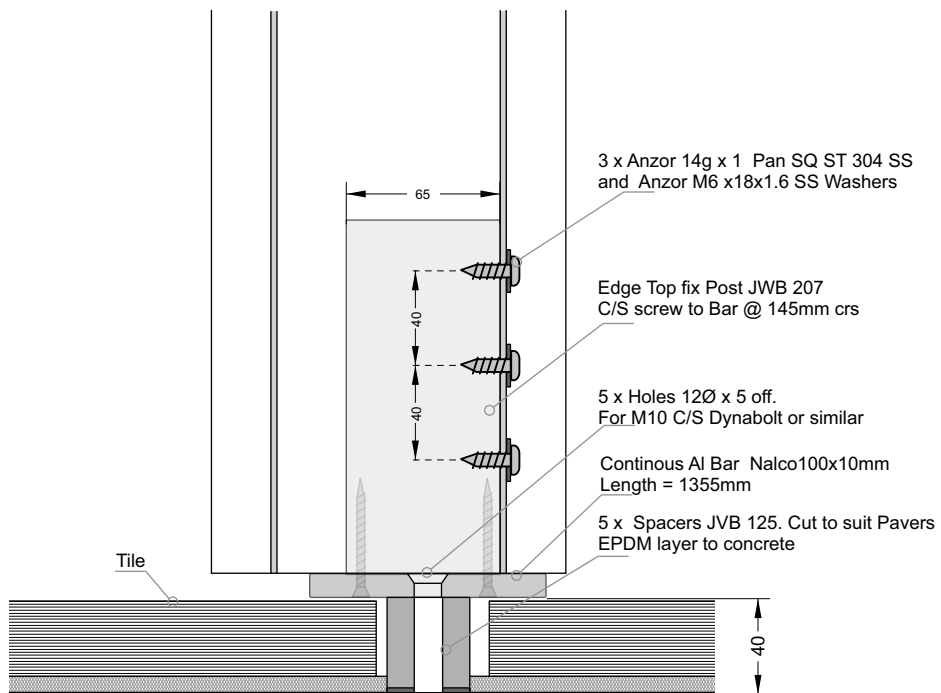
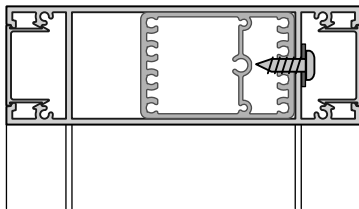

TOP FIX EDGE POST
Part No JEB/207/5

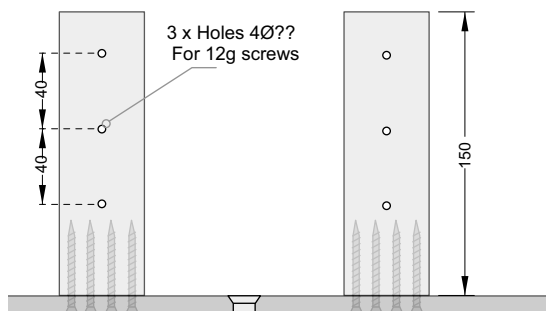

Juralco Louvrelite® Solar Control Systems
Rectangular Louvre 150 x 50

B Vertical Beam Attach. To 2 x 190x45 Boundary joists

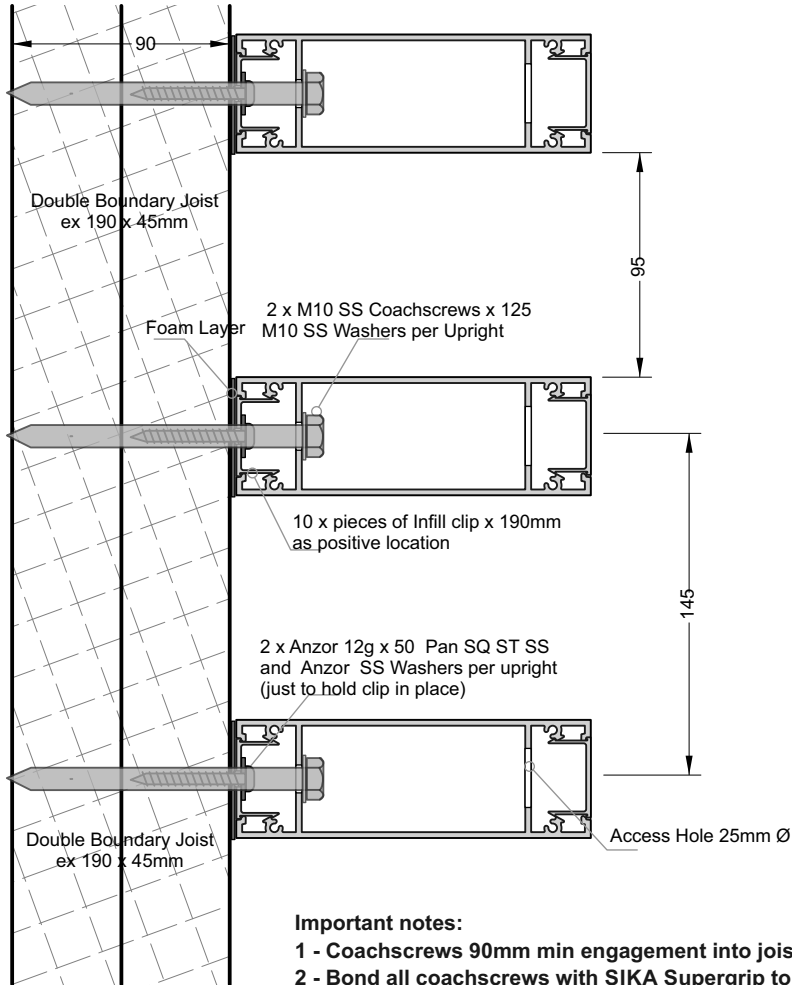

Important notes:

- 1 - Coachscrews 90mm min engagement into joists
- 2 - Bond all coachscrews with SIKA Supergrip to full depth
- 3 - All screw fixings must be Stainless steel

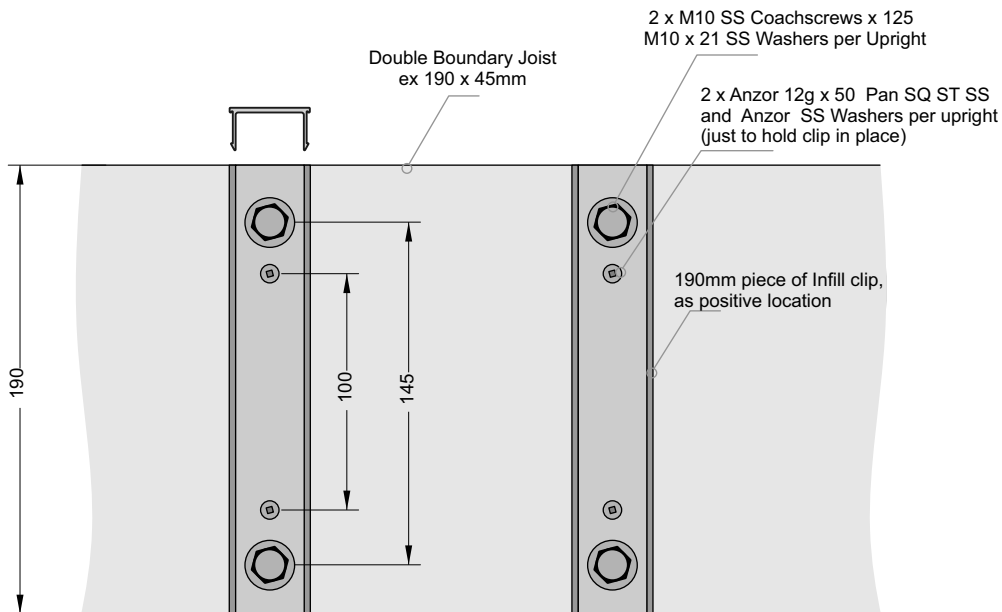

Important notes:

- M10 Coachscrew @ 145mm spacing, as for all Balustrade face fix
- Fix 10 x 190mm high infill clips to Boundary joist, before installing base.

Juralco Louvrelite® Solar Control Systems
Rectangular Louvre 150 x 50

Ⓒ Corner Joints. 45deg Miter. Incl corner angle



Pergola Extrusion
150mm x 50mm

Important notes:
1 - Assemble Brackets into Top Horizontal member,
then lower onto the Vertical members for final assembly

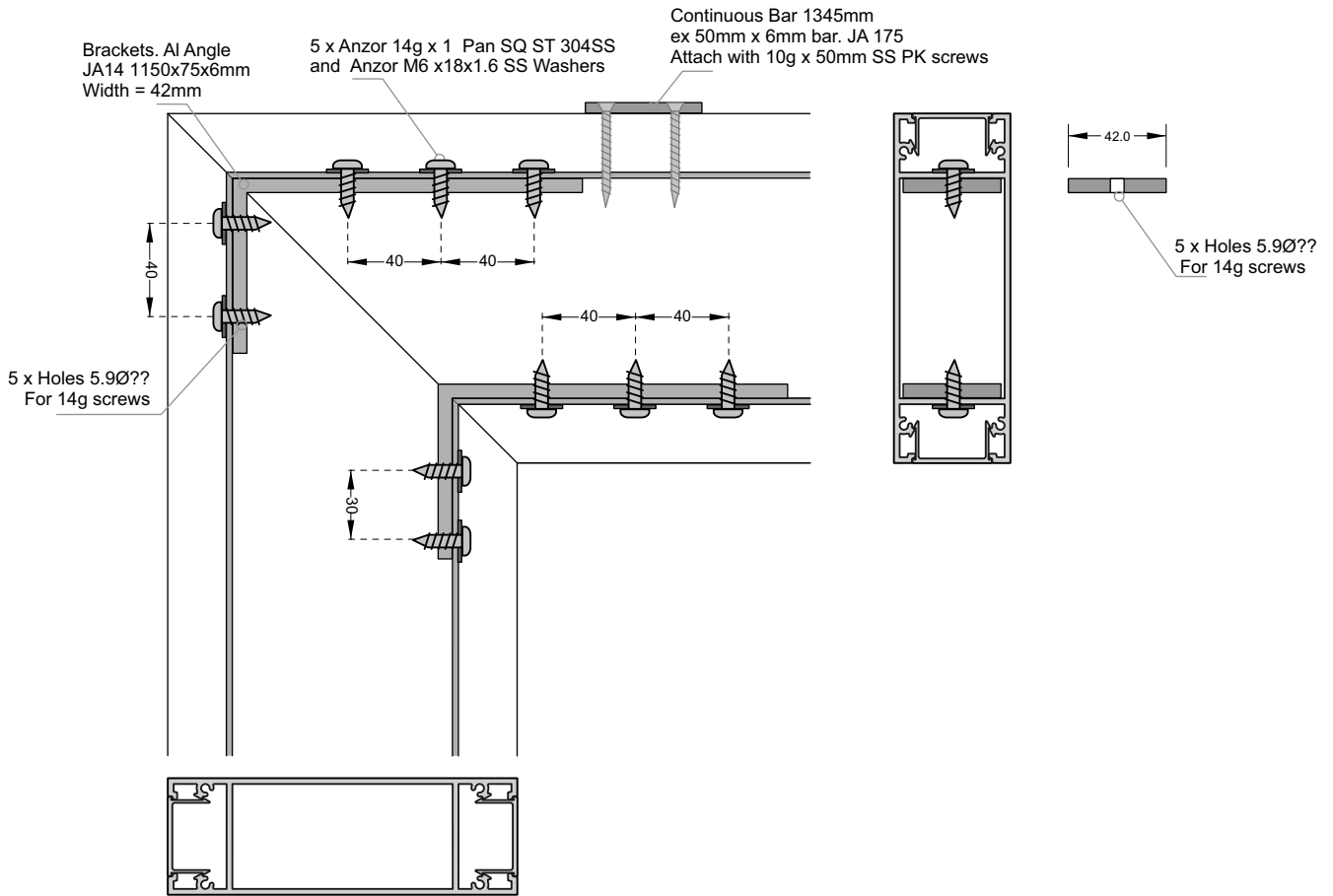

Juralco Louvelite® Solar Control Systems
Rectangular Louvre 150 x 50

Ⓓ Horizontal Beam Attach. To 150mm Tilt slab. Flashing on top - Same for Full and Half Bridge Types

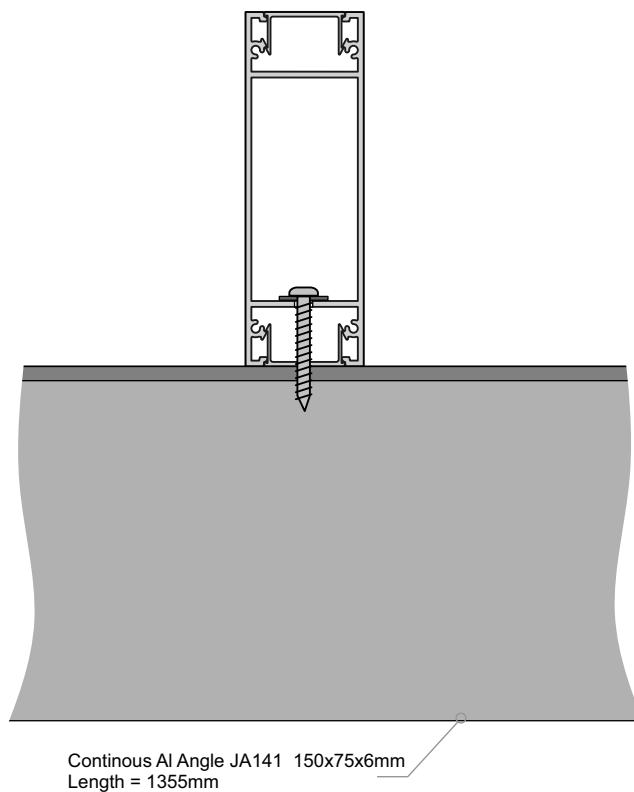
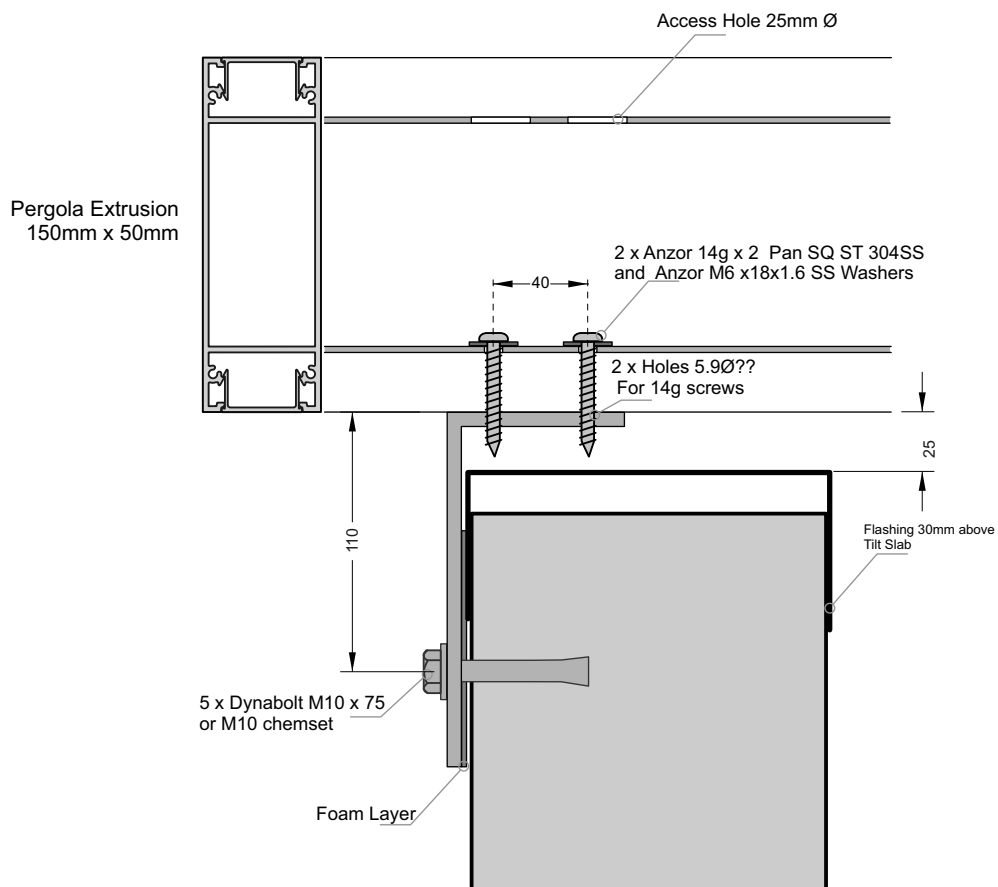

**Juralco Louvre[®] Solar Control Systems
Extrusions**

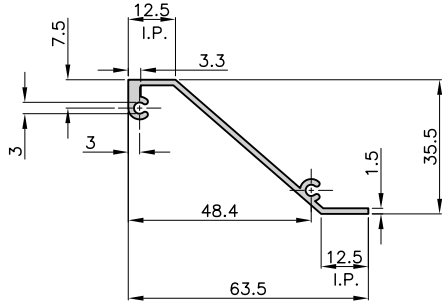

FIXED LOUVRE
JLV/2531/5

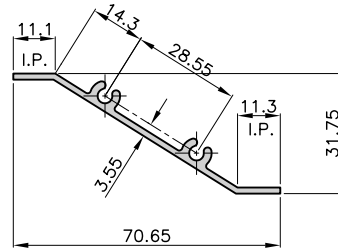

FIXED LOUVRE
JLV/2532/5

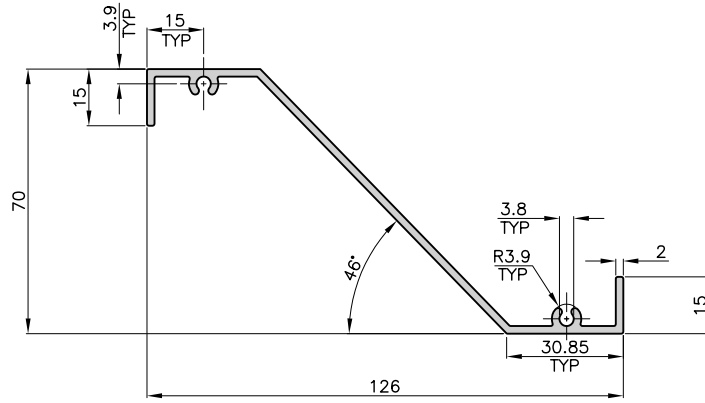

FIXED LOUVRE
JLV/2533/5

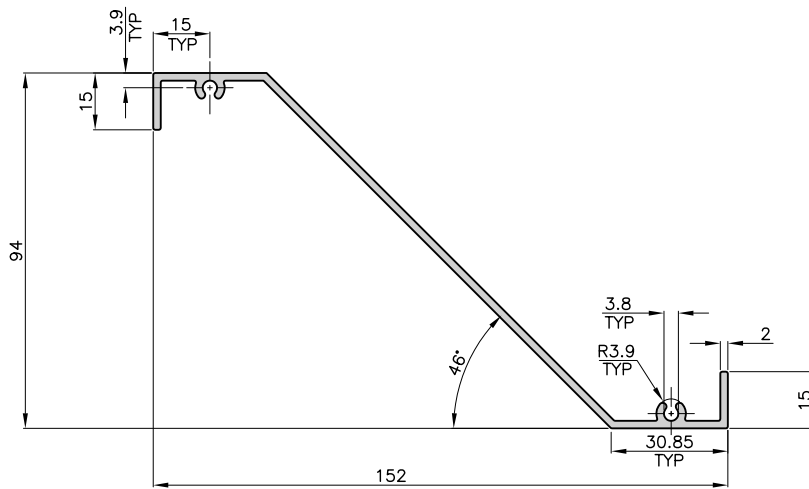

FIXED LOUVRE
JLV/2534/5

Juralco Louvrelite® Solar Control Systems
Curtain Wall; Standard Louvre Shapes. Special Order , Indent only

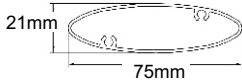

LOUVRE. JLV/50; t = 1.2mm, kg/m = 0.59

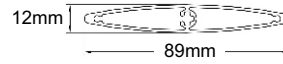

LOUVRE. JLV/51; t = 1.2mm, kg/m = 0.70

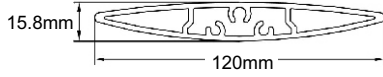

LOUVRE. JLV/52; t = 2.0mm, kg/m = 1.54

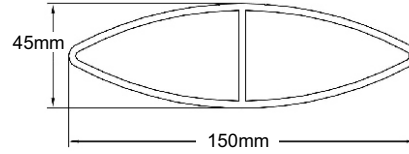

LOUVRE. JLV/53; t = 3.0mm, kg/m = 2.87

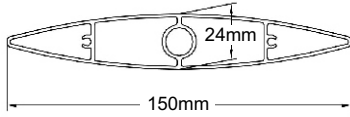

LOUVRE. JLV/54; t = 1.3mm, kg/m = 1.48

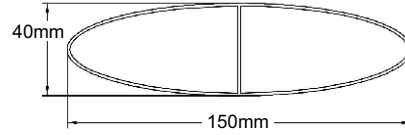

LOUVRE. JLV/55; t = 1.2mm, kg/m = 1.17

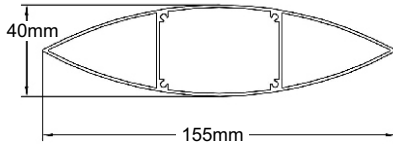

LOUVRE. JLV/56; t = 1.2mm, kg/m = 1.35

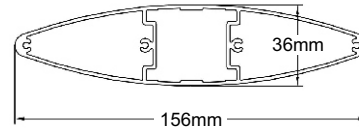

LOUVRE. JLV/57; t = 1.5mm, kg/m = 1.97

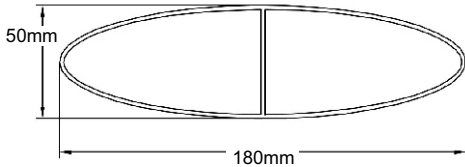

LOUVRE. JLV/58; t = 1.8mm, kg/m = 2.11

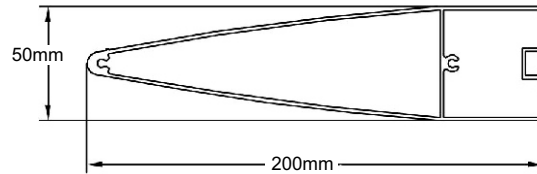

LOUVRE. JLV/59; t = 1.8mm, kg/m = 2.69

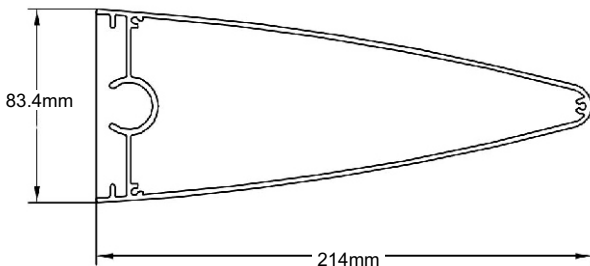

LOUVRE. JLV/60; t = 2.0mm, kg/m = 3.20

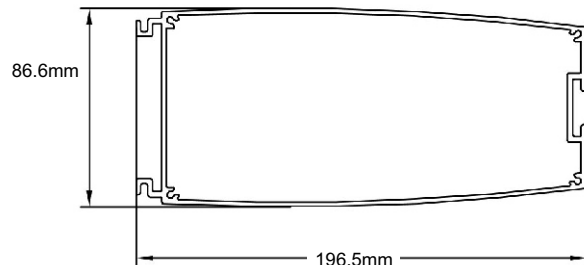

LOUVRE. JLV/61; t = 2.0mm, kg/m = 3.43

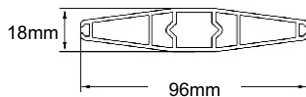

LOUVRE. JLV/62; t = 1.5mm, kg/m = 1.09

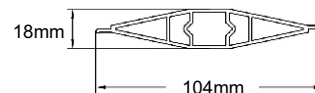

LOUVRE. JLV/63; t = 1.5mm, kg/m = 1.03

Juralco Louvelite® Solar Control Systems
Curtain Wall; Standard Louvre Shapes Special Order , Indent only

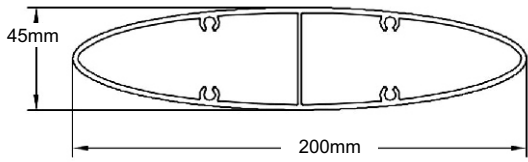

LOUVRE. JLV/64; t = 2.3mm, kg/m = 3.05

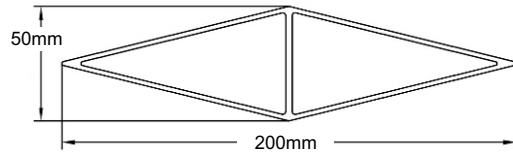

LOUVRE. JLV/65; t = 2.0mm, kg/m = 2.58

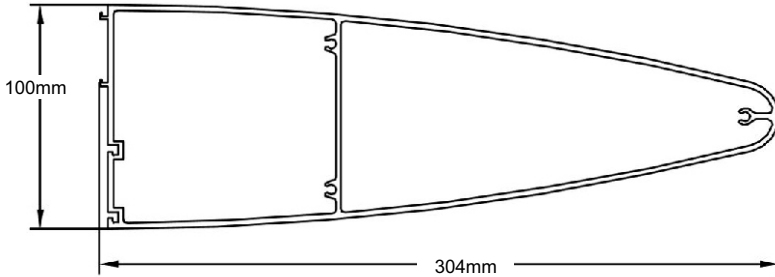

LOUVRE. JLV/66; t = 2.5mm, kg/m = 5.68

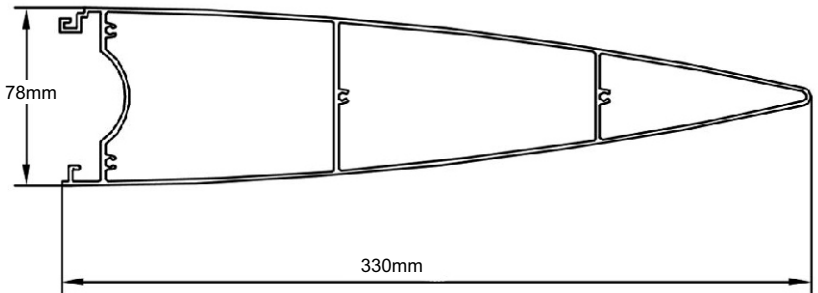

LOUVRE. JLV/67; t = 1.8mm, kg/m = 4.65

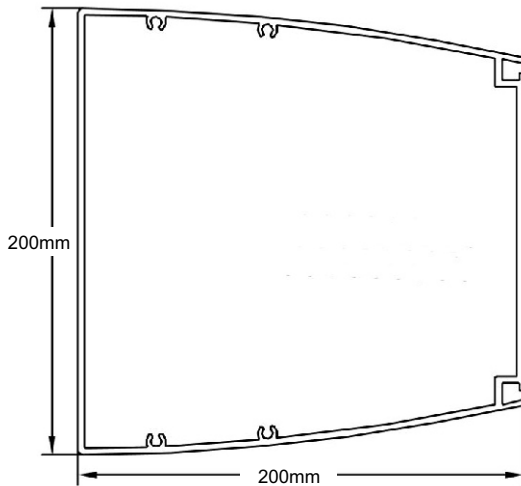

LOUVRE. JLV/68; t = 3.0mm, kg/m = 6.54

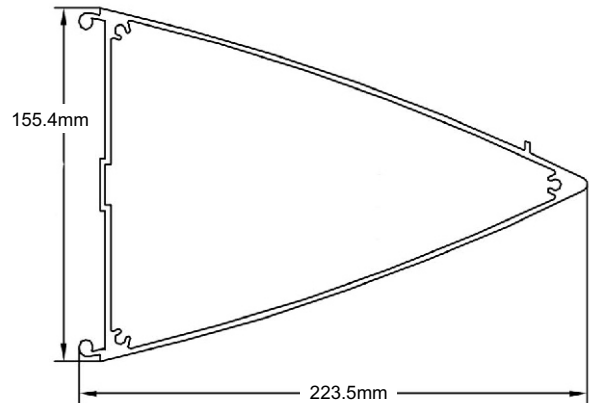

LOUVRE. JLV/69; t = 2.5mm, kg/m = 4.89

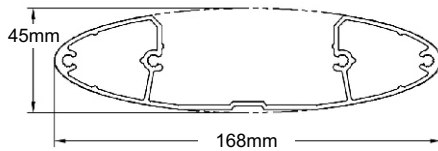

LOUVRE. JLV/70; t = 1.8mm, kg/m = 2.1

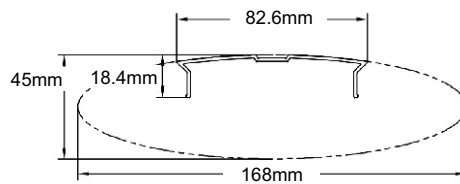

LOUVRE (fits JVL 70) JLV/71; t = 1.4mm, kg/m = 0.44

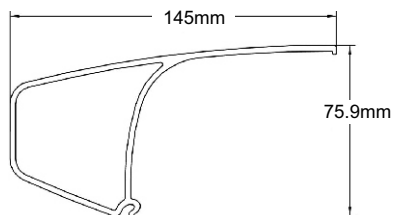

LOUVRE (fits JVL 73). JLV/72; t = 2.5mm, kg/m = 2.16

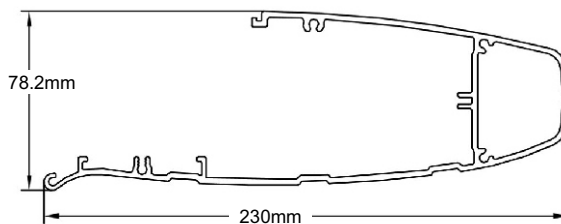

LOUVRE. JLV/73; t = 2.5mm, kg/m = 3.56

Juralco Louvrelite® Solar Control Systems
Curtain Wall; Standard Louvre Shapes Special Order , Indent only

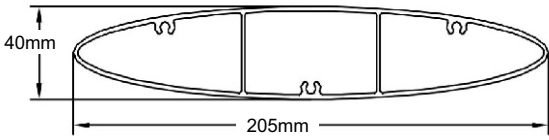

LOUVRE. JLV/74; t = 2.0mm, kg/m = 2.79

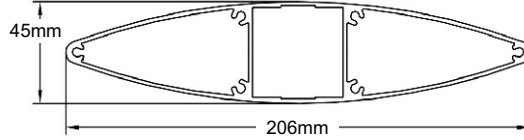

LOUVRE. JLV/75; t = 1.8mm, kg/m = 2.95

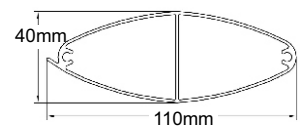

LOUVRE. JLV/76;
t = 1.2mm, kg/m = 1.02

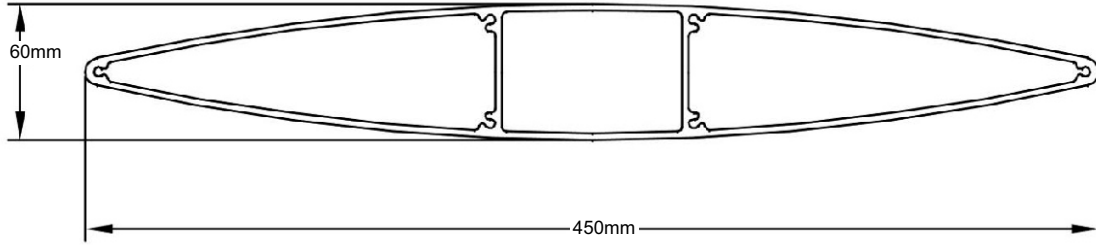

LOUVRE. JLV/77; t = 3.0mm, kg/m = 8.71

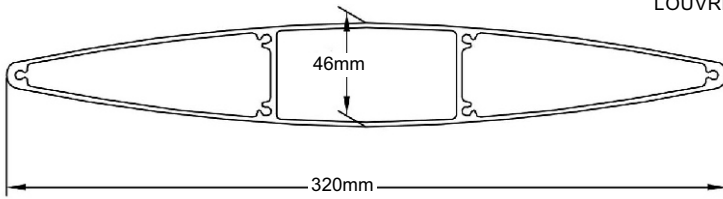

LOUVRE. JLV/78; t = 2.0mm, kg/m = 4.52

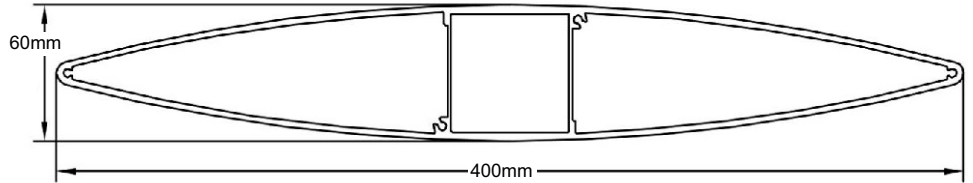

LOUVRE. JLV/79; t = 2.8mm, kg/m = 7.2

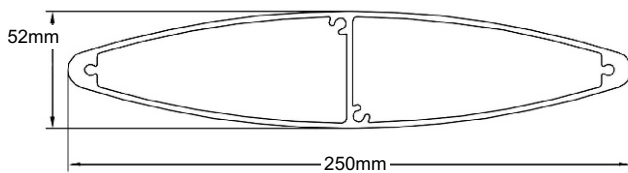

LOUVRE. JLV/80; t = 2.5mm, kg/m = 4.46

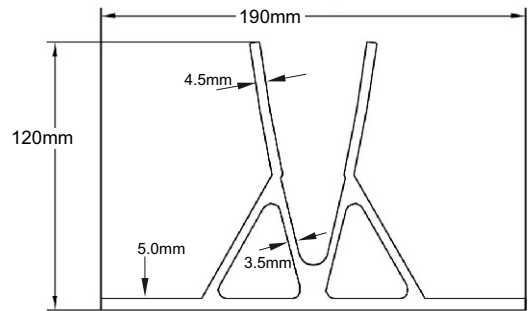

LOUVRE. JLV/81; kg/m = 6.92

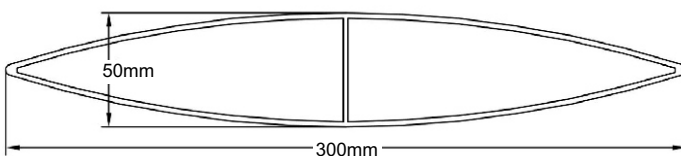

LOUVRE. JLV/82; t = 2.3mm, kg/m = 4.1

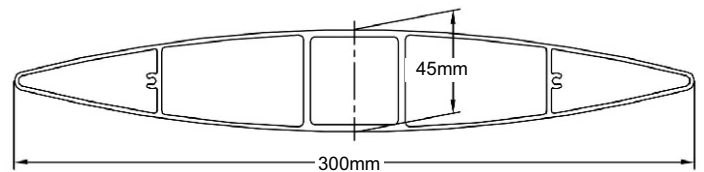

LOUVRE. JLV/83; t = 1.8mm, kg/m = 4.32

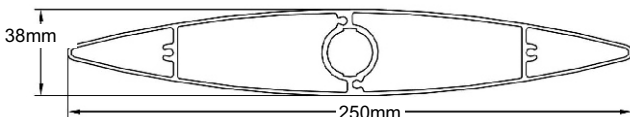

LOUVRE. JLV/84; t = 1.8mm, kg/m = 3.4

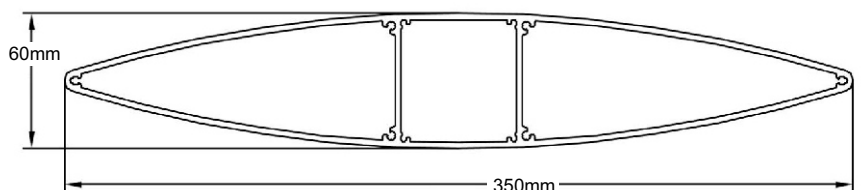

LOUVRE. JLV/85; t = 2.7mm, kg/m = 6.24

Juralco Louvelite® Solar Control Systems
Curtain Wall; Standard Louvre Shapes Special Order , Indent only

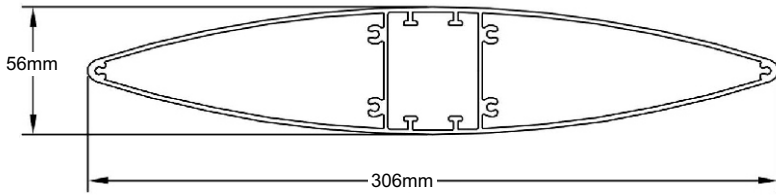

LOUVRE. JLV/86; t = 2.0mm, kg/m = 4.68

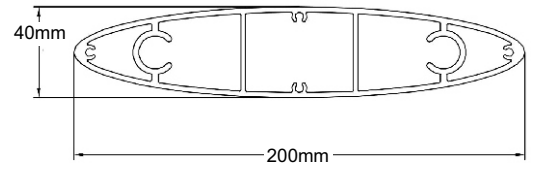

LOUVRE. JLV/87; t = 2.3mm, kg/m = 3.87

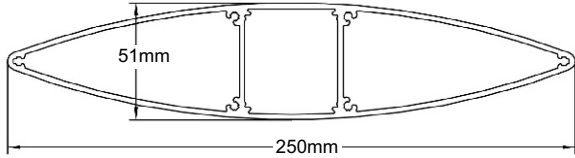

LOUVRE. JLV/88; t = 2.3mm, kg/m = 4.07

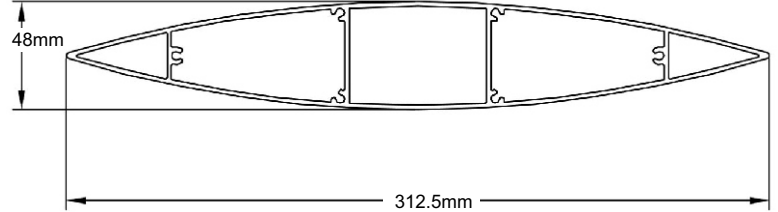

LOUVRE. JLV/89; t = 2.0mm, kg/m = 4.35

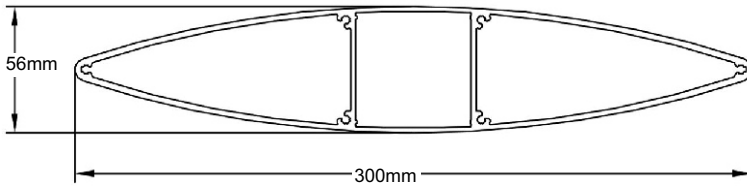

LOUVRE. JLV/90; t = 2.3mm, kg/m = 5.16

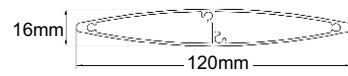

LOUVRE. JLV/91; t = 1.1mm, kg/m = 0.87

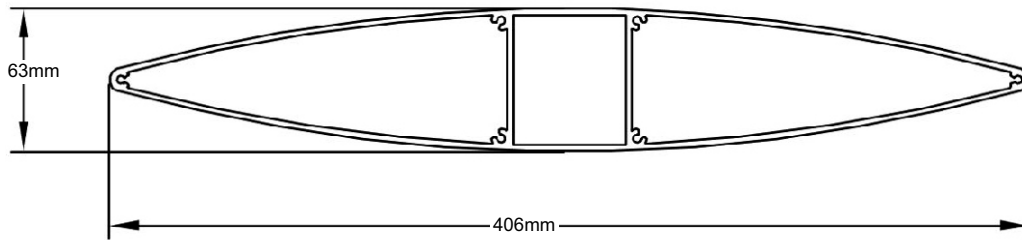

LOUVRE. JLV/92; t = 2.5mm, kg/m = 6.76

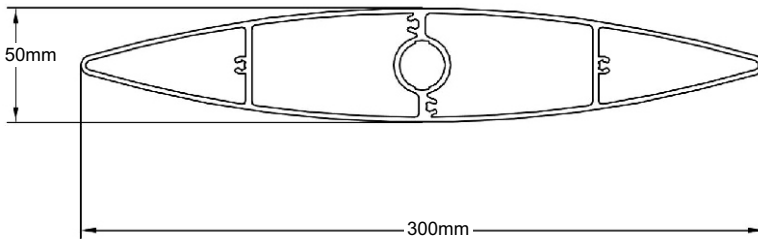

LOUVRE. JLV/93; t = 2.2mm, kg/m = 4.98

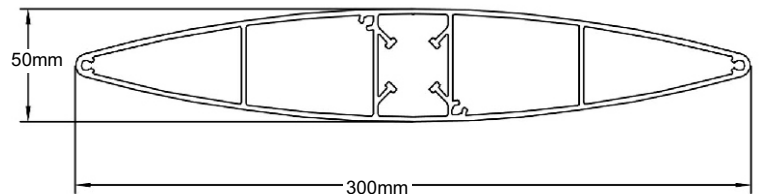

LOUVRE. JLV/94; t = 2.2mm, kg/m = 4.97

Juralco LouvreLite® Solar Control Systems

Powder Coating Care and Maintenance

Powder Coating Installation Care

Warning re use of solvents:

- In some cases strong solvents are recommended for thinning various types of paints and also for cleaning up mastics and sealants.
- These can be harmful to the extended life of the powder coated surface, and must not be used for cleaning purposes.
- It is important to note that the damage will not be visible immediately and may take up to 12 months to develop.

If paint splashes or sealants and mastics need to be removed then the following may be safely used:
Methylated Spirits, Ethyl Alcohol, Isopropanol or preferably a mild detergent in warm water.

Joinery Protection during Installation:

All the activity on a construction site means that your powder coated items may get knocked or scratched, splattered with mortar, plaster, textured coating or paint during the later stages of construction.

Please ensure that all powder coated articles are masked or covered at this time. It is far easier to prevent accidents than to try and correct them.

Should your joinery receive mortar or paint splashes see that these are removed before cure and follow the instructions contained in this brochure.

Typical sticker used to warn other trades of the need to protect and mask off powder coated joinery (applies to anodised joinery also)

"IMPORTANT ALL TRADES"
This valuable aluminium joinery will suffer permanent damage from: plaster, mortar and paint splashes - Protect if splashes occur - Immediately wash down joinery with water or meths - Do not allow splashes to harden! ~ Do not use solvents! - Do not remove this label until final clean completed.

This photograph displays damage that has occurred on site, post installation. The photo of the masked joinery displays clear signs of damage that could have occurred were it not masked. Please ensure that your joinery is protected right through the entire construction process.



Powder Coating Maintenance

External - Maintenance Program:

To extend the life of external powder coated articles and to comply with warranty requirements for powder coated aluminium joinery, a simple, regular maintenance program must be implemented.

The effects of ultra violet light, atmospheric pollution, dirt, grime and airborne salt deposits will all accumulate over time and must be removed or surface staining and weathering will occur, leading to an unsightly appearance.

For external coatings, cleaning should take place every six months. In areas where pollutants are more prevalent, such as beachfront houses and industrial or geothermal areas, then a cleaning program should be carried out on a more frequent basis ie. every one to three months.

Fences or Balustrades in close proximity to swimming pools must be washed down every six months, to clean off chlorine and salt deposits.

Cleaning your powder coating:

1. Carefully remove any loose surface deposits with a wet sponge.
2. Use a soft brush (non abrasive) and a mild household detergent (do not use solvents) in warm water, remove dust, salt and other deposits.
3. Rinse off with clean fresh water.



Restoring weathered or scratched surfaces:

Repair of Scuffed or Scratched surfaces
Dulux Spray Cans are available in all colour card colours.

Repair of Small Scratches or Chips.
Dulux Dabsticks are ideally suited for the repair of small scratches.
Dabsticks may not be available in all colour card colours.

Repair of Weathered areas .
Dulux Gloss Up is a light to medium cutting cream ideally suited for gloss restoration and has been specifically designed for this purpose.
Gloss Up contains no waxes or silicone and is a one step system.



Contact Dulux Powder Coatings , ph 0664 9 441 8244

All pages © Copyright Juralco Aluminium Building Products Ltd, 2023



JURALCO

www.juralco.co.nz ph (09) 478 8018

Juralco LouvreLite® Solar Control Systems

Issue 3-23 v1
Page 52