



HomePlus® Outdoor Living System

Structural - Wall attach, Distributed Load

Notes:

1 - Only applicable to Louvres perpendicular to Wall ie Distributed Load

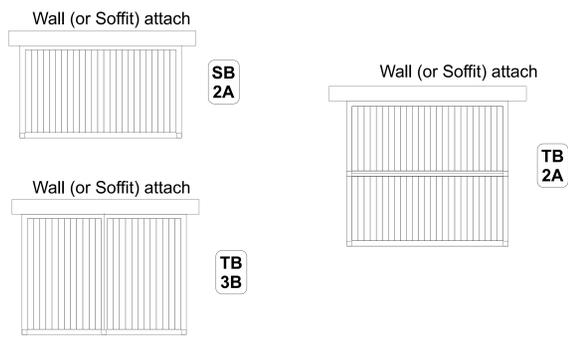

Wall Series. Louvres Perpendicular to Wall

Total Uplift loads, according to the appropriate Wind Zone are resisted by the Wall attachments. At the Wall/Soffit the load is equally distributed over the whole length. Multiple bracket attachments for Soffit are available. For Wall attachment, check the manual. Juralco has recommendations for the Initial connection of the Bask Frame to a Building Structure. The further connections to the Structure must meet the Wind Zone/Specified forces as in the Structural Tables. This is the responsibility of the Builder and/or Engineer.

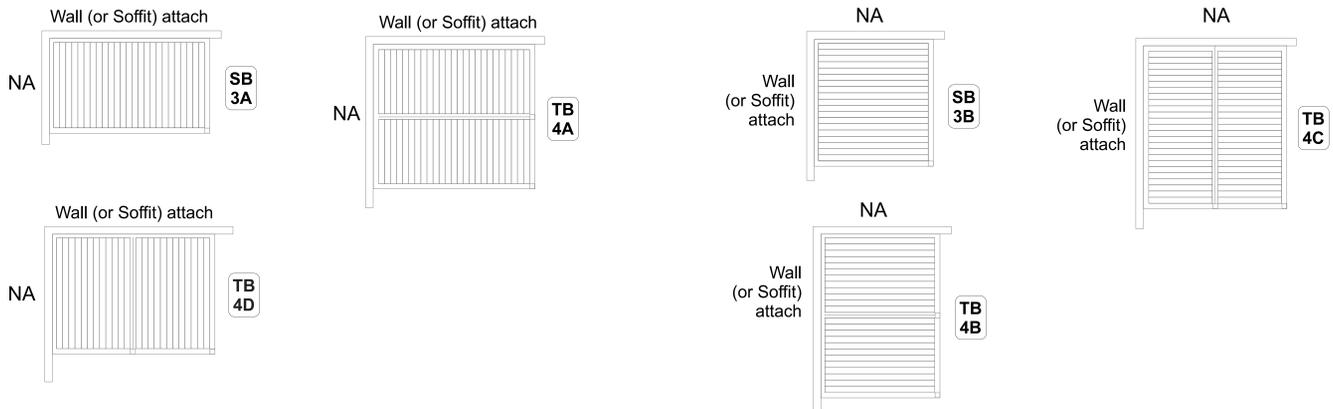

Important Note:

Juralco can only guarantee the suitability of the initial connection. In this case the M10 Coachscrews attaching the JOR507 Wall Beam to the Timber Packer and to the Wallboards + Studs All subsequent connections and strengthening to a structure are the clear responsibility of the builder/ installer. Any other specifications on this page are general suggestions only. Please refer to the HomePlus Outdoor Living System/ Manual/Structural/Configurations/Areas/Wind Zones for guidance on Forces the structure will have to withstand.

Step 1

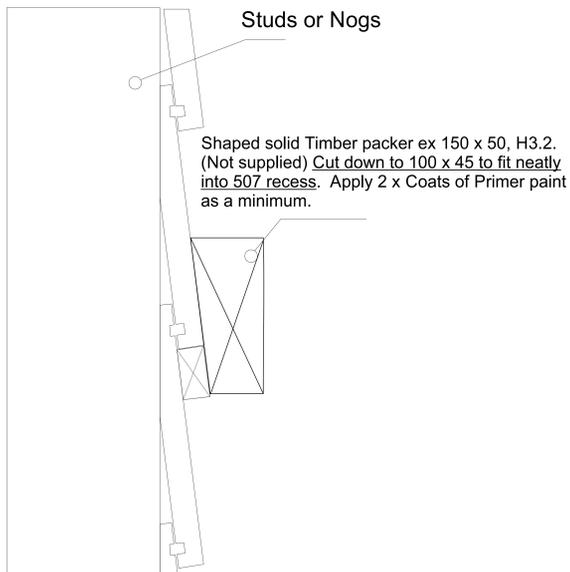

Step 2

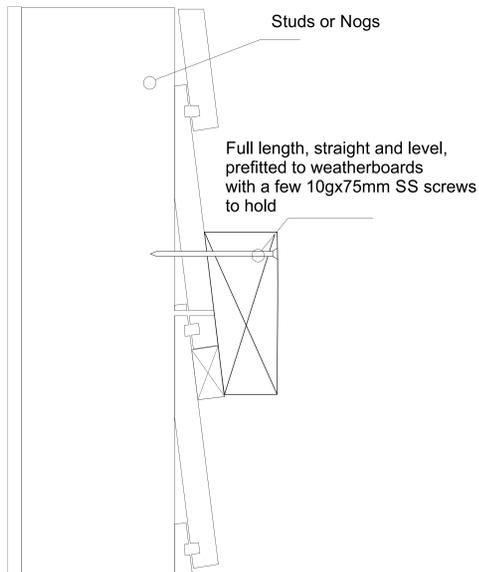

Step 3

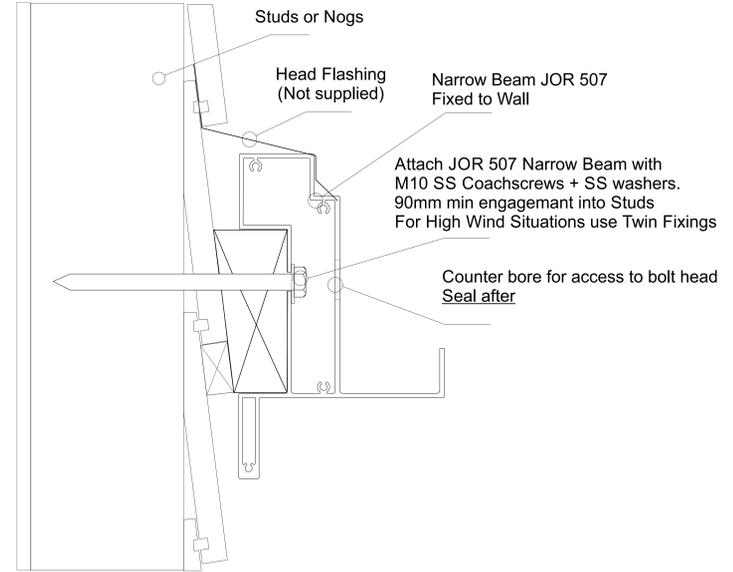

Important Installation Notes:

- 1 - A Design engineer must ensure the building structure can support the appropriate wind loading
- 2 - Coachscrews 90mm min thread engagement into joists
- 3 - Bond all coachscrews with SIKA Supergrip to full depth
- 4 - An EPDM, Rubber or Foam Tape layer must be installed between the JOR 507 and Timber
- 5 - All fixings must be Stainless Steel