



 JURALCO

JURALCO SOLARZIP™ AWNING SYSTEM

ISSUE 1-24 v1

Juralco Aluminium Building Products Ltd designs and distributes specialist aluminium joinery systems through a national network of franchised fabricators and agents.

For more than 25 years we have been at the forefront of specialist aluminium door and window products suitable for New Zealand joinery and building methods. Our comprehensive product range includes security and insect screens, balustrades and gates, shutters and awnings, shower screens, wardrobe doors and organisers and internal doors.

The Juralco SolarZip™ Awning is a compact, ready-to-install, vertical screen system designed for outside use anywhere protection is needed from sun or rain.

All of the components are made of aluminium alloy, powder coated to your requirements, forming a highly-resistant, lightweight, rust-proof construction.

The awning is designed to adapt to all types of openings up to 4m wide.

Installation is straightforward. SolarZip™ awning operation is either manual or by a tubular electric motor, fitted with remote control.

A range of attractive light filtering fabrics are available.

Index

Pages	Codes	Description
3	Features	Shows various features of the Zip Dropscreen Standard Layouts
4 - 7	Materials	Shows all Extrusions and Components
8	Electrical	Shows In line Motors and controls
9 - 10	Measuring up	Shows important measured dimensions
11 - 13	Installation	Shows Installation and cutting calculations
14	Order Form	Shows Zip Drop Screen Order Form
15	Council	Shows consent exemptions
16	Powder Coat	Care and maintenance Exterior Powder coated surfaces

Important information - Powder Coating systems.

Powdercoat Systems The new standard Dulux powder coating system used by Juralco is Duralloy Plus®. Also Duralloy® and Duratec®. Juralco Powder coated prices are for Duralloy Plus® and Duralloy® (same pricing). Duratec® prices on application. The following specs apply to Building Exteriors.

- Dulux Duralloy Plus® powder coating systems are suitable for properties greater than 10m from high tide level. Residential and Light commercial buildings, 3 levels max. Warranty 15 yrs
- Dulux Duratec® powder coating systems are suitable for properties greater than 10m from high tide level. All Residential and Commercial buildings. Warranty 25 yrs.

Attachment to structures A PVC Tape or similar material spacer must be used to separate powder coated aluminium items from all concrete and steel structures. Failure to do so can lead to the chemicals in the structure affecting the powder coating, leading to corrosion.

Swimming Pools The chlorinated water in swimming pools can cause the deterioration of powder coated surfaces, leading to corrosion of the underlying surface. It is recommended that Powder coated surfaces be 1200mm min from a pool.

Care The Dulux powder coating warranty period is conditional upon the surface being maintained in accordance with the Dulux 'Care and Maintenance Instructions'. Download from Dulux or refer to the back page of this manual.

Juralco Solar Zip™ Awning System - General

SolarZip - General

Complete with Side guides,
as shown below.

Manual Gearbox (or Motorised)

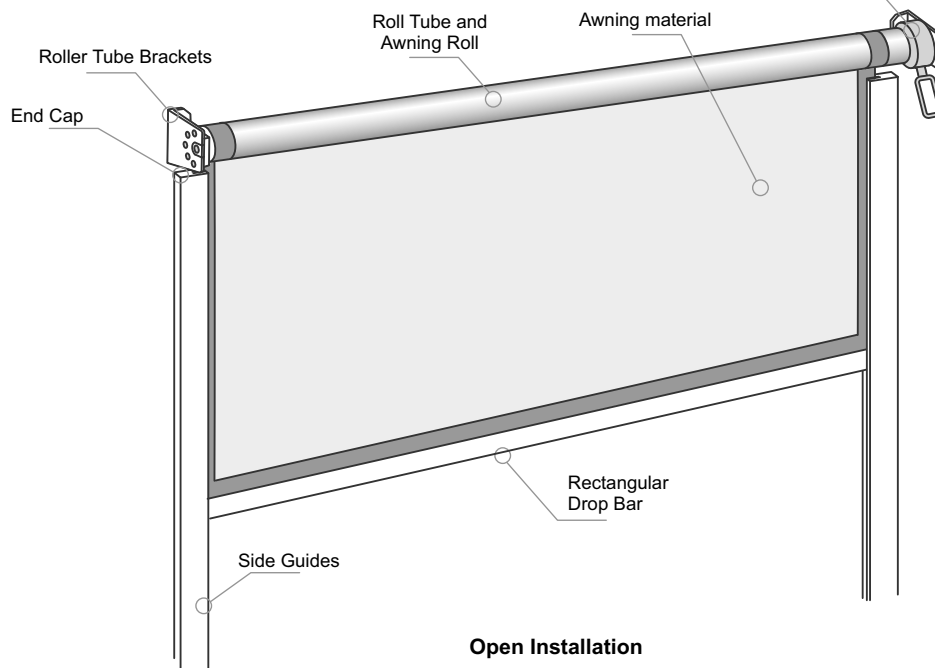

Open Installation

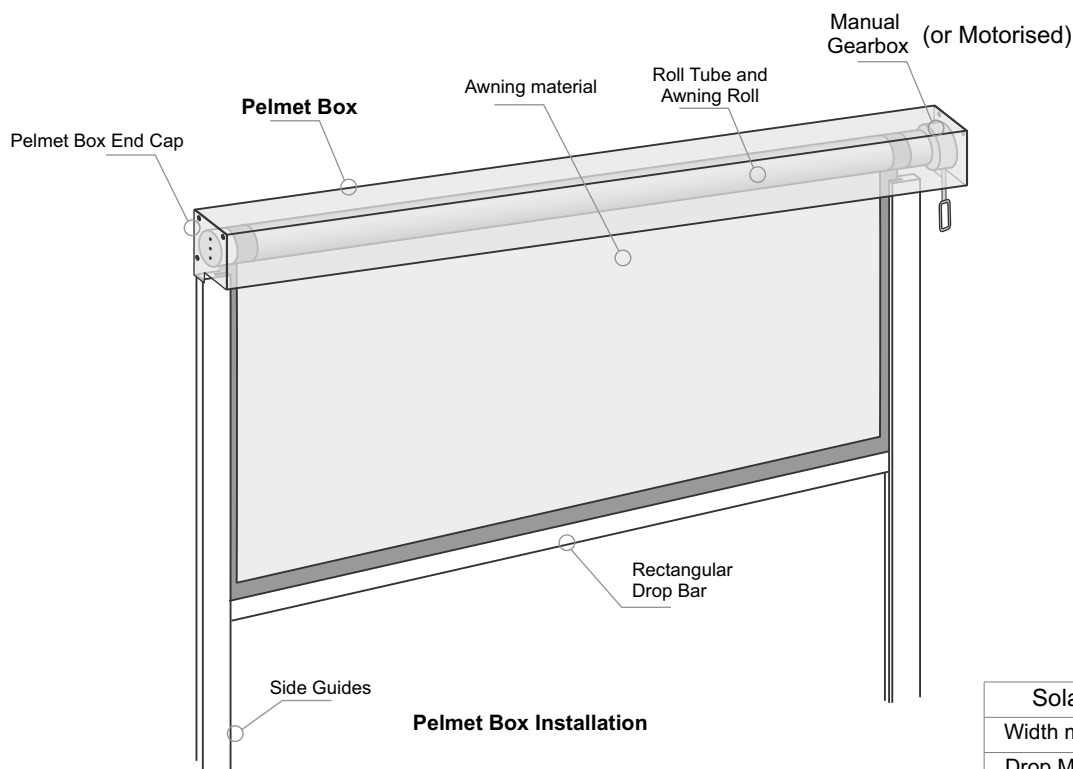

Pelmet Box Installation

SolarZip Awning	
Width max	4mt
Drop Max	3mt

The Juralco SolarZip Awning consists of :

Open type installation with exposed Roller Tube Brackets, or a **Pelmet Box, (enclosed)** made of aluminium extrusions suitable for face or soffit installation. Supports the ends of the Roller Tube.

Operation by means of a R1:7 gearbox/handle, or tubular motor (with or without manual override).

Roller tube, 2mm wall aluminium extrusion 80mmdia, with a groove to fix the awning fabric. One end equipped with the operating system and the other mounted with a circular shaft.

Side Guides, 60mm x 30mm vertical aluminium extrusions, incorporating a plastic floating inner extrusion.

Drop Bar, a heavy 42mm x 20mm horizontal dropper.

Awning, Solarview, or Aspect Atmosphere awning materials.

Awning fabrics will withstand wind, rain and pollution.

The fabrics are colour durable and resistant to most common chemicals, mildew, and UV degradation; all have a minimum five-year guarantee. Aspect fabrics have a 10yr warranty

Finishes, Cast aluminium parts - powder coated Grey.

Aluminium extrusions - Anodised or, powder coated to order.

Controls A wireless connected Sun and Rain sensor (JNICENemo/SRT) can be installed to guard against sudden rain showers.

Juralco SolarZip™ Awning System - Extrusions

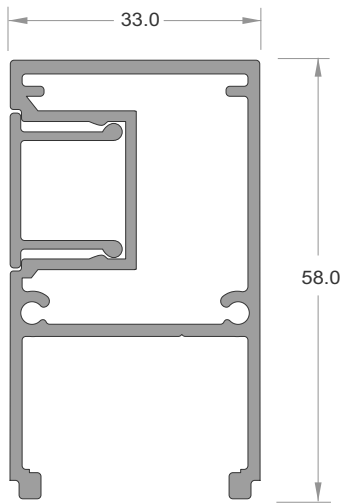

SIDE GUIDE
Part No JZP/CS/14000

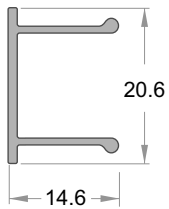

STANDARD INFILL CLIP
JEB/206/5.8

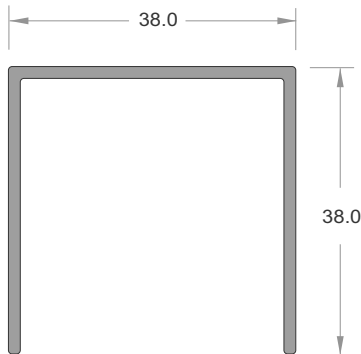
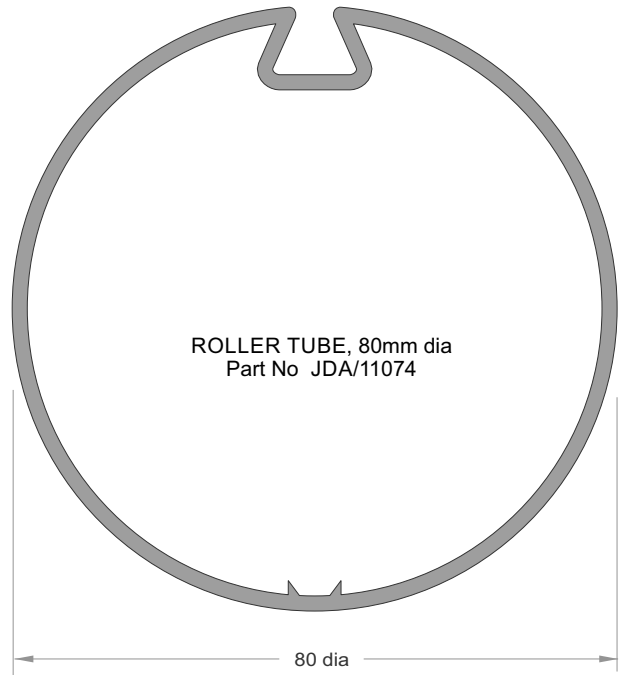

SIDE GUIDE WALL CHANNEL
Part No JA 275

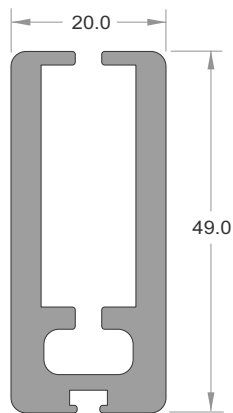

BOTTOM BAR
Part No JZP/CS/16000



I RAIL (plastic)
Part No JZP/CS/12011/Black



E PROFILE (plastic)
Part No JZP/12021/Black

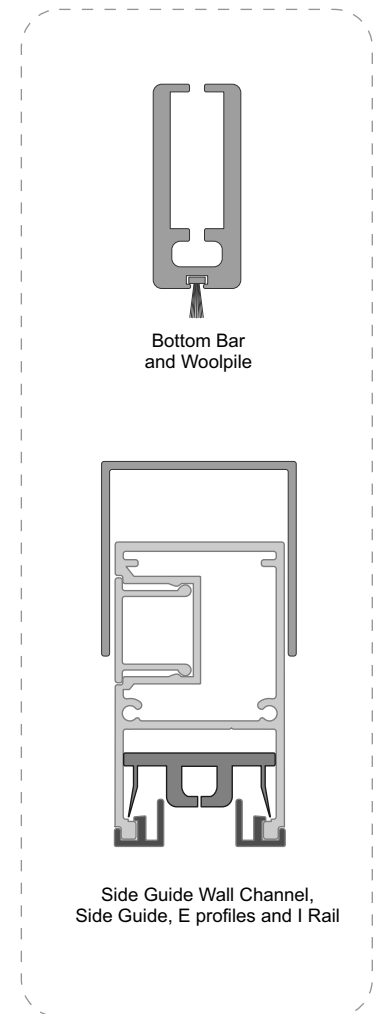

Side Guide Wall Channel,
Side Guide, E profiles and I Rail

Juralco SolarZip™ Awning System - Extrusions

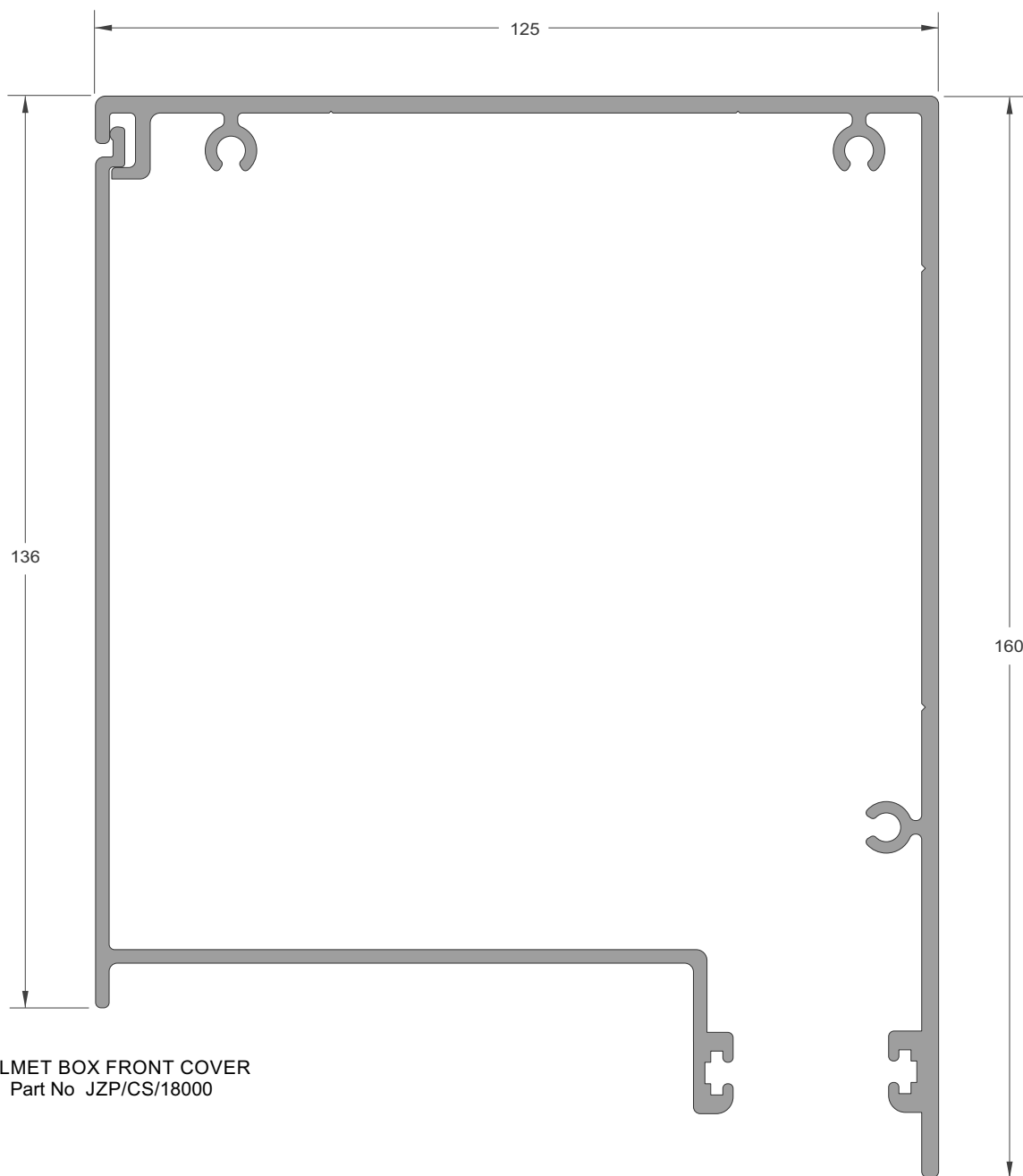

PELMET BOX FRONT COVER
Part No JZP/CS/18000

PELMET BOX BASE
Part No JZP/CS/17000

Juralco SolarZip™ Awning System - Components

Roller Tube End Cap
Part No JZP/SM/51036

Roller Tube End Cap
Part No JZP/SM/51047

Roller Tube Mounting Bracket
Part No JBA/4031542

Set = Pair, 1 x RH, and 1 x LH

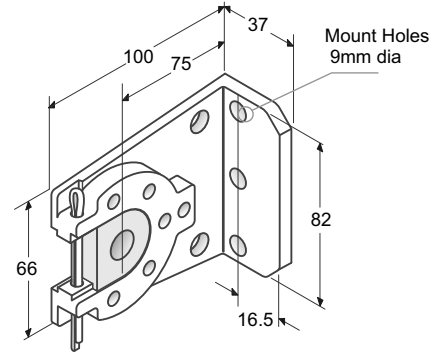
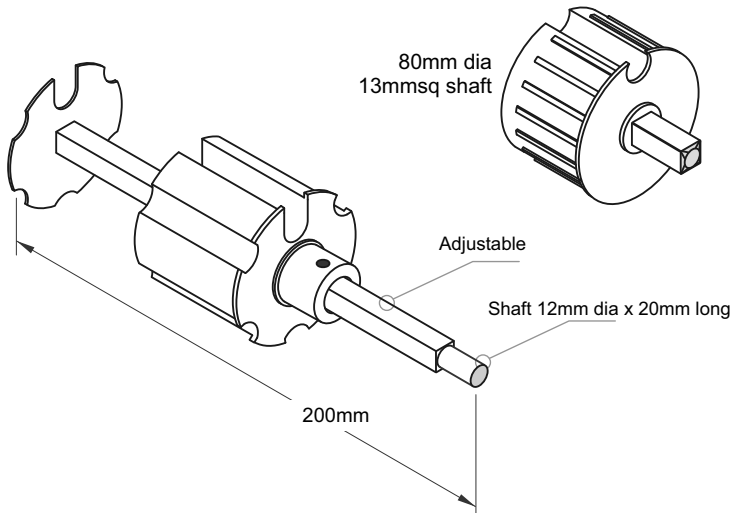

Note - Not for use with Pelmet Box or BASK installations

SolarZip Conning Adapters

Pelmet Box End Caps
RH, LH. 126mm x 160mm

Roller Tube Bracket
PN JZP/SM/73120

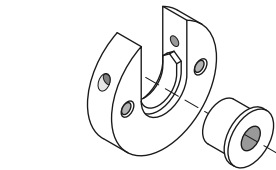
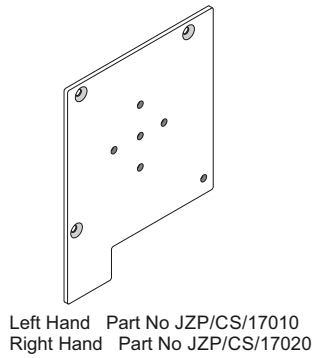
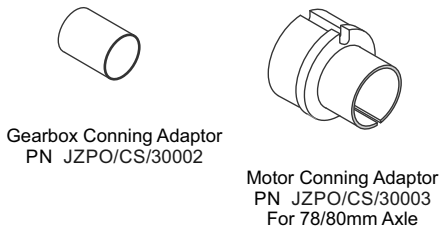

For use in Pelmet Box; includes Plastic Bearing

Bottom Bar
Plastic End Clips

RH and LH as a set.
2 x sets per
Bottom Bar

Side Guide End Caps
Part No JZP/CS/14030



Part No JZP/SM/16501/White
Part No JZP/SM/16503/Black

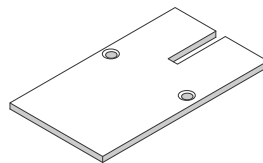

Black PVC

Weldable SolarZip
Part No JZP/CS/20010

SolarZip Fall Bar Mohair
Part No JRF/98/10

SolarZip Front Cover Bracket
Part No JGF/HSBlock

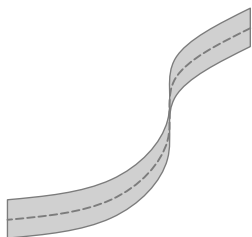

Lengths 1m, Grey

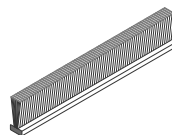

Lengths 1m, Black

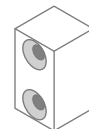

17mm x 17mm x 30mm high

Juralco SolarZip™ Awning System - Components

Manual Gearbox 1:7
Part No JDA/403 6607

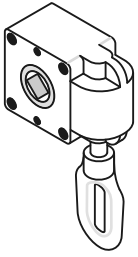

Gearbox Handle

Gearbox Handle
Clip, Pt No
JDA 4026500

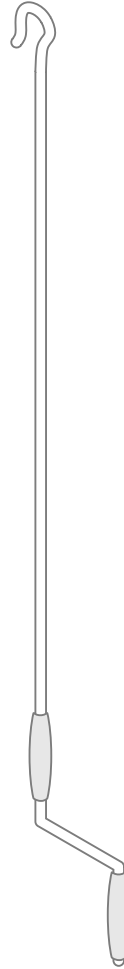

JDA/4030431 - 1200mm
JDA/4030592 - 1400mm
JDA/4030593 - 1600mm
JDA/4030595 - 2000mm

Juralco SolarZip™ Awning System - In Line Motors and Controls

Tubular Motors
JNICE ERA M 3017 and 5012

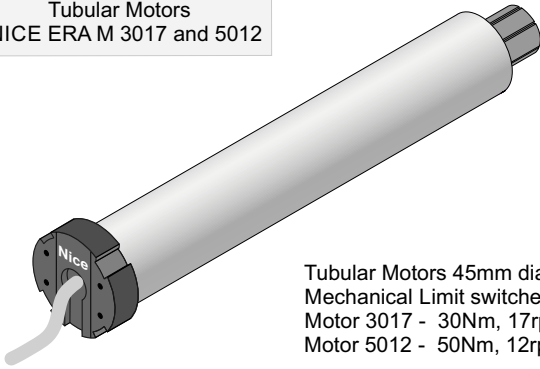

Tubular Motors 45mm dia
Mechanical Limit switches
Motor 3017 - 30Nm, 17rpm
Motor 5012 - 50Nm, 12rpm

POWER CABLE

Length 2.5 m, 4 wires in cable



Tubular Motors
JNICE ERA PLUS 3017 and 5012

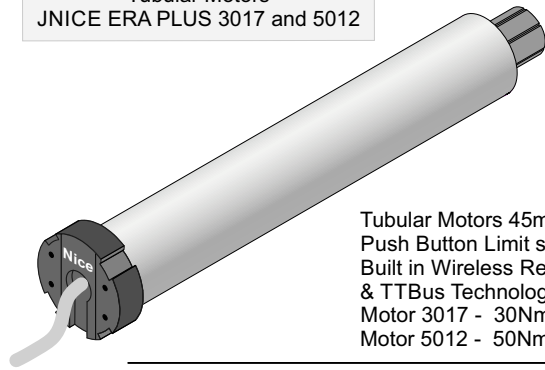

Tubular Motors 45mm dia
Push Button Limit switches
Built in Wireless Receiver
& TTBus Technology
Motor 3017 - 30Nm, 17rpm
Motor 5012 - 50Nm, 12rpm

POWER CABLE

Cable length 2.5 m, 6 wires in cable

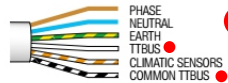

These wires must be isolated if not being used

Motor Mount Brackets
NICE 535.10092

For 45mm dia Motors
Compact aluminium support. 2 x holes M6 at 48 and 60mm CL

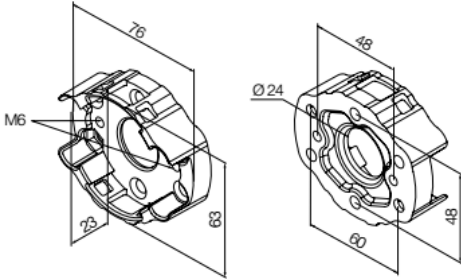

Manual Controls
Switch Controls

Wall Controls

3 position Rotary Wall Switch
Up - Off - Close
Cover Plate - SSW 770 CPSM
Switch - SSW 770 RSB

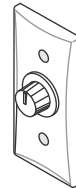

Wireless

Remote Controls

Wireless Receiver

JNICE/BIDIAWNING. Nice controller for Wireless operation. Can be added to Switch operation and Manual override Motors to make for wireless control



Drive Wheel and Crown
JNICE/45ROUND78



Wireless

Remote Controls

Portable Wireless Transmitters



P1 P6 P18

- P1 Portable transmitter to control 1 electrical load system or automation group
- P6 Portable transmitter to control 6 electrical load systems or automation groups for activation in single or multigroup mode
- P18 Portable transmitter to control 18 electrical load systems or automation groups for activation in single or multigroup mode

Motor Remote Control Sensors

Wind Sensor threshold has 3 wind speed settings
15, 30, 45 Kph

Sun Sensor has settable range 5 - 60klux
Rain sensor on/off



JNICE/WIND/S
Volo Wind Sensor



JNICE/NEMO/SRT
Sun and Rain Sensor

NEMO VIBE does not require any additional connections because it is battery powered. It screws to the front of the awning. During windy conditions, a signal (adjustable) is sent via radio signal to the motor mounted in the awning, which then retracts the awning.



JNICE/NEMOVIBE
Vibration Sensor

Juralco SolarZip™ Awning System - Fabric, Measuring

Fabric Ranges

Solarview Sunscreen

Solarview is 30% polyester/70% PVC fabric manufactured and designed for controlling heat and light in our harsh NZ climate.

The sturdy 2 x 2 weave ensures the fabric is a pleasure for manufacturers to work with, and a clean cut can be guaranteed with any method of manufacture. Rolls 30m long, all colours 3000mm wide; a selected range 2500mm wide.

Solarview is a light filtering fabric, flame retardant, mould and mildew protected.

To clean, wipe with warm soapy water and damp cloth. Suitable for both internal and external applications and is easily weldable.

Aspect Atmosphere Sunscreen

Aspect is 30% polyester, 70% PVC fabric manufactured and designed for controlling heat and light in our harsh NZ climate.

18 Colours available in two widths. Rolls 30m long, all colours 3000mm wide; a selected range 2500mm wide.

Aspect sunscreen is a light filtering fabric, flame retardant, mould and mildew protected.

To clean, wipe with warm soapy water and damp cloth. Suitable for both internal and external applications. 10 yr warranty

Measuring - No Pelmet Box

On site Check List:

- 1 - Check the desired width and installation area, making sure there are no obstructions.
- 2 - Check that the Mounting brackets have secure fixing points
- 3 - Line up the outside of the Side guide with the outside of the Roller Bracket
- 4 - Check side guides mounting.
- 5 - Check the desired awning material.
- 6 - Check end for gearbox or motor operation



All these Horizontal Measurements, NOT using Side Wall Channel.

- 1 - Axle = Overall Width -160mm
- 2 - Bottom Bar = Overall Width -135mm
- 3 - Mohair for Bottom Bar = Overall Width -100mm

- 4 - Vertical Side Guides, I Rail, E Profile, Side Wall Channels (if used)

Reveal Fix = Overall Drop - 145mm

Face Fix = Overall Drop - 120mm

- 5 - Fabric, NOT using Side Wall Channel.

a - Top corners mitre 50mm x 50mm

b - Overall Width -100mm. (To give finished Fabric Width with Zips of O/A Width -85mm)

c - Finished Height = Overall Drop +100mm

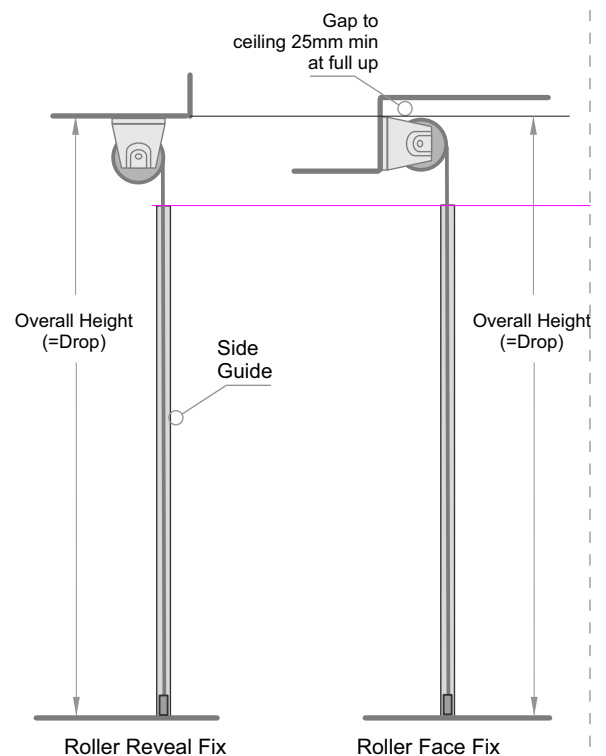

Juralco SolarZip™ Awning System - Measuring

Measuring - With Pelmet Box

On site Check List:

- 1 - Check the desired width and installation area, making sure there are no obstructions.
- 2 - Check that the Pelmet Box Base has secure fixing points
- 3 - The max overall width will be the Pelmet box width
- 4 - Check side guides mounting style; check mounting points
- 5 - Check the desired awning material.
- 6 - Check end for gearbox or motor operation

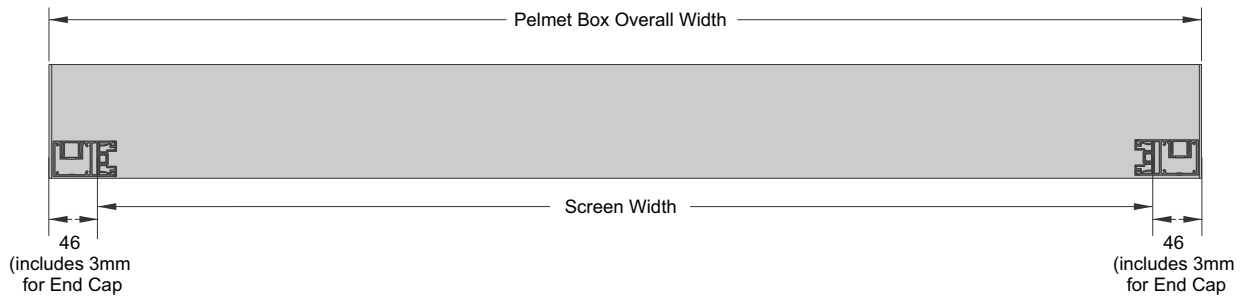
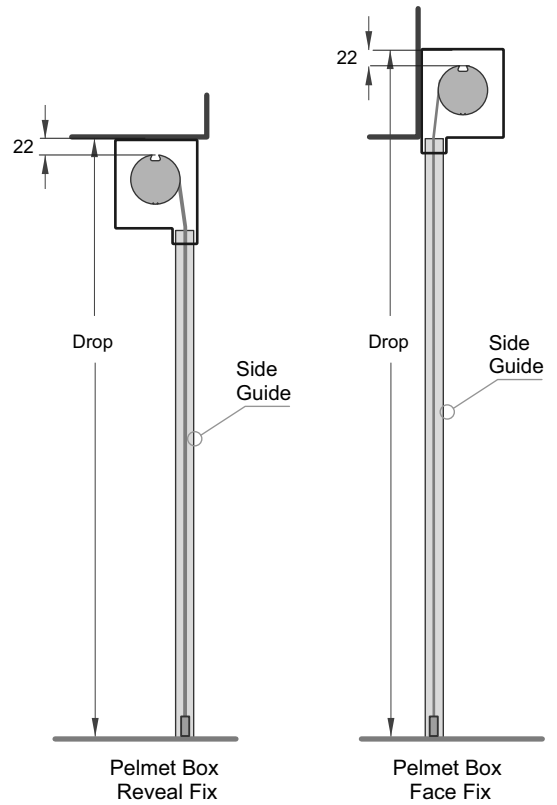

Juralco SolarZip™ Awning System - Installation

Installation
No Pelmet Box

Note: Prior to delivering to site, unpack and check all items

- 1 - Carefully unpack and check for damage.
BE VERY CAREFUL THE AWNING IS NOT ACCIDENTLY CUT during unpacking.
- 2 - Check the awning, making sure it has been made to site measurements.
- 3 - Mark out Roller Tube Mounting Bracket positions on Wall/Soffit. Install.
Note - Brackets must be firmly mounted into the building structure and be level.
- 4 - Insert the Awning/Roller tube 13mm dia square axle into Gearbox/Motor end.
Insert the adjustable 12mm dia axle to the other bracket. Screw in place.
- 5 - Insert and tighten all screws.
- 6 - Attach Top End Caps, then install the Side Guides, off sets as below. They must be parallel.
- 7 - Feed bottom edge of curtain into the Bottom Bar. Insert Plastic end clips each end.
- 8 - Check for smooth operation, Adjust limits.
- 9 - Always clean off all fingermarks, leave the site clean and tidy.

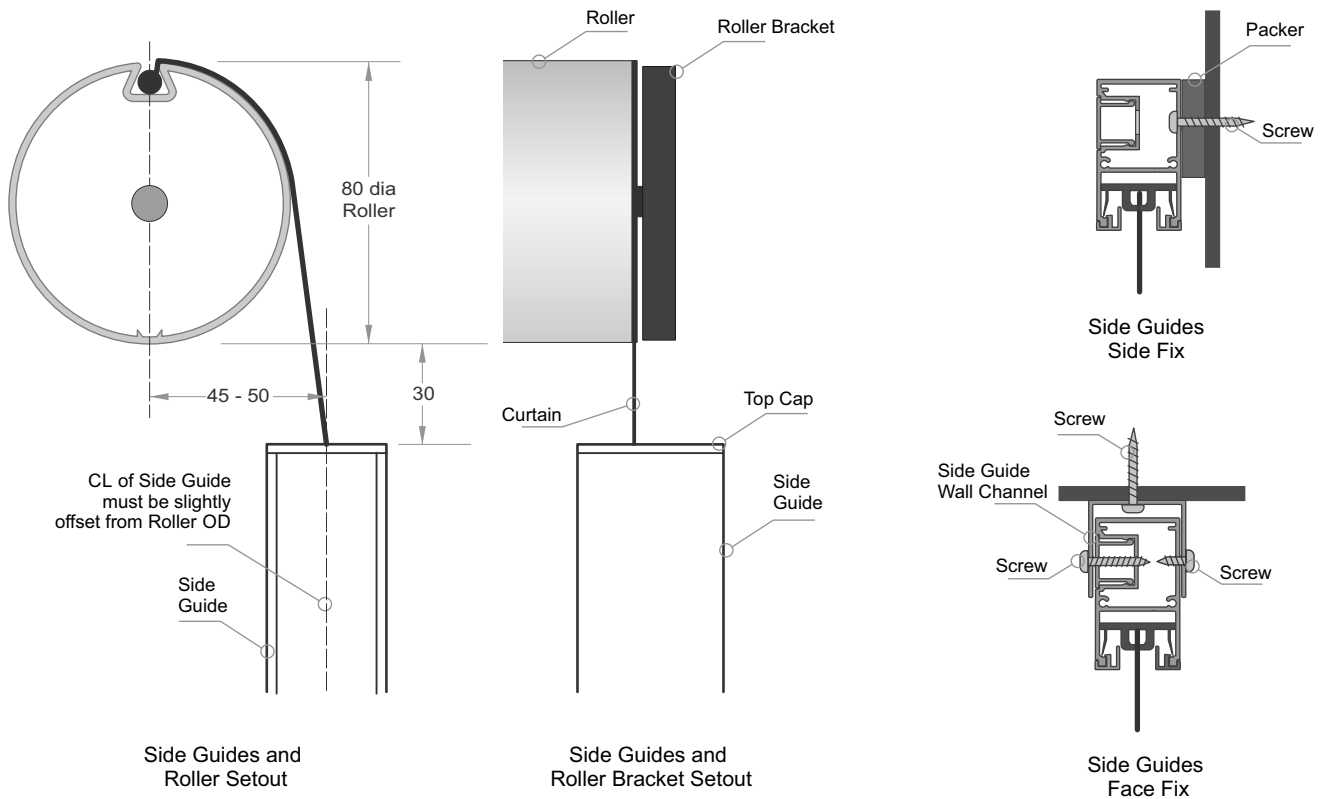

Juralco SolarZip™ Awning System - Installation

Installation With Pelmet Box

Note: Prior to delivering to site, unpack and check all items

- 1 - Carefully unpack and check for damage.
- 2 - Check the Awning, making sure it has been made to site measurements.
- 3 - Remove Pelmet Front Cover. Remove the Roller and attached Screen and Bottom Bar
- 4 - Attach Pelmet Box Base using Packers if needed to square up.
Note - Base must be firmly mounted into the building structure and be level.
- 5 - Reinsert the Awning/Roller tube 13mm dia square axle into Gearbox/Motor end.
Drop the adjustable 12mm dia axle and bearing to the other bracket. Screw in place.
- 6 - Insert and tighten all screws.
- 7 - Install the Side Guides. Screw attach to the Pelmet Base.
Use packers and Screw attach to Wall. All to be square and parallel.
- 8 - Release the Bottom Bar and feed into the side guides.
- 9 - Check for smooth operation, Adjust limits.
- 10 - Clip Pelmet Box Front cover in place, screw attach at bottom.
- 11 - Always clean off all fingermarks, leave the site clean and tidy.

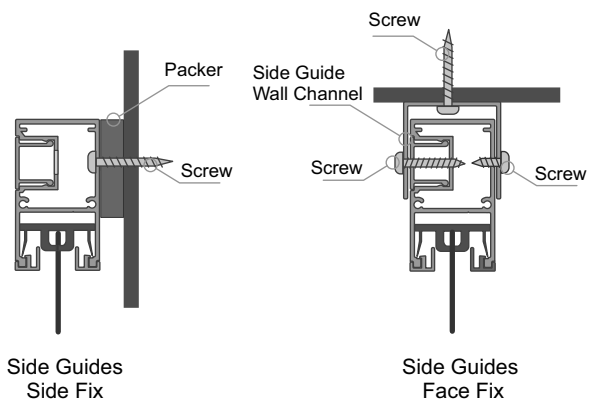
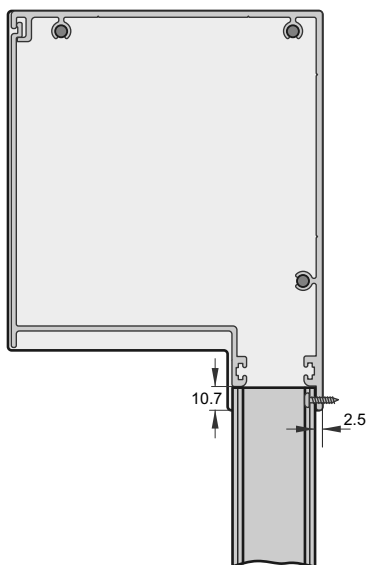
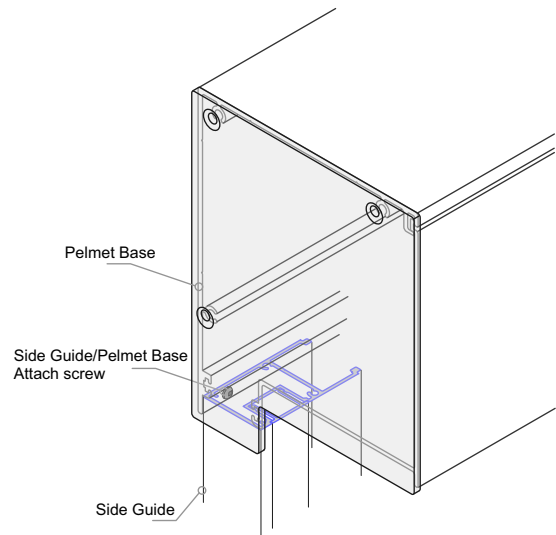
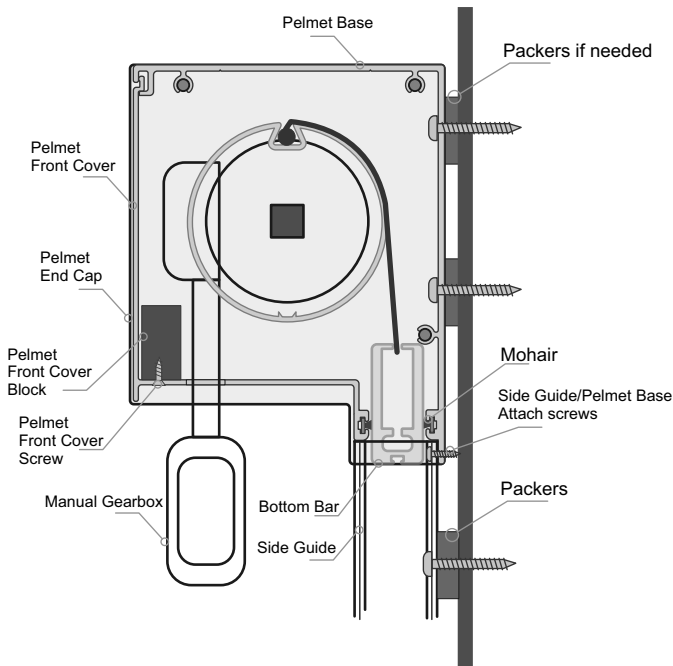

Juralco SolarZip™ Awning System - Cutting Allowances

Extrusion Cutting Allowances	MANUAL GEAR BOX, No Pelmet	MOTORISED GEARBOX, No Pelmet
	Axle = OA Width - 160mm	Axle = OA Width - 145mm
	Bottom Rail = OA Width - 140mm	Bottom Rail = OA Width - 140mm
	Guides = OA Height - 120mm	Guides = OA Height - 120mm
	Wall Channel = OA Height - 120mm	Wall Channel = OA Height - 120mm

Extrusion Cutting Allowances	MANUAL GEAR BOX, with Pelmet Box	MOTORISED GEARBOX with Pelmet Box
	Axle = OA Width - 167mm	Axle = OA Width - 145mm
	Bottom Rail = OA Width - 140mm	Bottom Rail = OA Width - 140mm
	Guides = OA Height - 150mm	Guides = OA Height - 150mm
	Wall Channel = OA Height - 160mm	Wall Channel = OA Height - 160mm
	Pelmet Box = OW Width - 7mm	Pelmet Box = OA Width - 7mm
	Cover Box = OA Width - 7mm	Cover Box = OA Width - 7mm

Canvas Cutting Allowances	FOR ALL TYPES
	Width = OA Width - 100mm
	Height = OA Height + 100mm

Juralco SolarZip™ Awning System Worksheet/Order Form
Juralco Aluminium Building Products Ltd, 48 Bruce McLaren Rd, Henderson, Auckland
Phone: (09) 478 8018 Fax : (09) 478 7883

Use one order form per each SolarZip order. Check all information carefully before sending this order.
 Juralco will not commence production until a signed order has been received .
 Remember , this is a one off custom unit made to your measurements and specifications.

Customer Name.....**Date**.....

Address.....

Delivery Address.....

Phone No...... **Contact**..... **Order No** **Awning No**.....**of Total**.....

1 Enter Overall Measurements

Overall Drop Overall width

From Top of Headbox if used, or Top of Roll to Floor level. Overall Width, to outside of Side guides

- Any combination of dimensions.
- Drop 500min - 2800max, Width 1000min - 4000max

SolarZip Awning

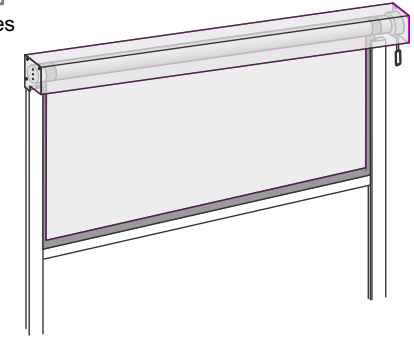

2 Select Mount Type

Open Type

Pelmet Box

Bask

3 Select Motor or Gearbox

If for Bask, must be Motorised

Motor Gearbox

4 Select Motor or Gearbox End, viewed from Front

LH RH

5 If Gearbox Select Handle Length

NA 1200mm 1600mm 2000mm 2400mm Wall Clip

6 Select Powder Coat Type

Duralloy

Duratec

Specify PC Colour and Code

7 Select Fabric Type and Colour

Planasol

Dickson

Solarview

Specify Fabric Colour and Code

8 Motor Controls, if Motor

Switch Remote

9 Volo Wind sensor, if required

Yes No

10 Additional Motor Remote Control? BIDI/Awning + Portable controller. Tick to select

P1 P6 P18

11 Notes:

Juralco SolarZip™ Awning System

These two pages are an extract from the Department of Building and Housing

- Building Work that does not require a Building consent - pages 21 to 24. Online at www.dbh.govt.nz/bc-no-consent
- These are new exemptions dated Dec 2010

While every effort has been made to ensure that this information is correct at time of writing, it is provided for guidance only and Juralco will accept no liability for, nor warrants the accuracy of this guidance. It is the sole responsibility of the of the purchaser to confirm current status of consent requirements with the relevant territorial authority before purchase and installation.

Awnings

Awnings.

Exemption (ja) of Schedule 1

A building consent is not required for the following building work:

- (ja) the construction, alteration, or removal of any fabric, glass, or metal awning on any building that-
 - (i) is on the ground or first storey level; and
 - (ii) does not exceed 20 sqmt in size.

Guidance:

Awnings are usually coverings that are fabric, glass or metal. They are normally attached to the exterior of a building and are commonly used for protection from sun, rain or as a wind buffer (eg, a shadesail or window awning). The installation of awnings that are 20 sqmt or less on any building at a ground floor or first floor level will comply with this exemption.

Size is a factor for large awnings, as they can damage the walls they are attached to or adjacent property or potentially injure people in high winds. Accordingly, any awnings larger than 20 sqmt require a building consent.

This exemption relates to awnings which are currently attached or are to be attached to a building's external envelope or exterior surfaces.

Awnings may be removed, altered and constructed, providing this work complies with the Building Code. Particular emphasis should be placed on weather tightness detailing when removing, altering and constructing such structures. All mechanical connections (eg, nuts, bolts, coach screws etc) which penetrate the building envelope and provide support to awnings must provide adequate resistance to moisture getting into the structure. Please note, this exemption does not relieve the owner of any other requirements under the Resource Management Act 1991 and or local district plan rules and provisions.

Examples where this exemption could apply:

A shadesail is to be attached above a deck at first floor level of a dwelling. The proposed shadesail has a total area of 18 sqmt, and meets all Building Code requirements.

The removal of an existing 12 sqmt awning providing shade at the entry to a building (situated at first floor level).

Examples where building consent is required:

A glass awning is to be fitted to an apartment on the sixth floor of the building. Though the awning has a total coverage of 14 sqmt, it is not exempt because of its height above ground and a building consent is required.

Territorial Authority discretionary exemptions

Territorial authority discretionary exemptions

Exemption (k) of Schedule 1

A building consent is not required for the following building work:

- (k) any other building work in respect of which the territorial authority (or, as the case requires, the regional authority) considers that a building consent is not necessary for the purposes of this Act because that building work-
 - (i) is unlikely to be carried out otherwise than in accordance with the building code; or
 - (ii) if carried out otherwise than in accordance with the building code, is unlikely to endanger people or any building, whether on the same land or on other property.

Guidance:

Exemption (k) allows a discretionary decision to be made by a territorial authority (city or district council) or regional authority (regional council) to exempt proposed building work from the requirement to obtain a building consent in the circumstances specified in (i) and (ii), above.

Members of the public may ask their local council to consider their proposed building work under this exemption. However, the decision to allow any exemption under this part of Schedule 1 is totally at the council's discretion, based on the risk of building work not complying with the Building Code or endangering people or property.

Local councils should have procedures for making formal decisions under exemption (k) to exempt building work, that meet the specific criteria of (i) and (ii) above, from the requirement to obtain a building consent.

In all cases, the Department recommends that the decision, reason for the decision and the outcome of the decision be recorded by the local council and placed on the property file that relates to the building work.

Juralco SolarZip™ Awning System - Powder Coating Care and Maintenance

Powder Coating Installation Care

Warning re use of solvents:

- In some cases strong solvents are recommended for thinning various types of paints and also for cleaning up mastics and sealants.
- These can be harmful to the extended life of the powder coated surface, and must not be used for cleaning purposes.
- It is important to note that the damage will not be visible immediately and may take up to 12 months to develop.

If paint splashes or sealants and mastics need to be removed then the following may be safely used:
Methylated Spirits, Ethyl Alcohol, Isopropanol or preferably a mild detergent in warm water.

Joinery Protection during Installation:

All the activity on a construction site means that your powder coated items may get knocked or scratched, splattered with mortar, plaster, textured coating or paint during the later stages of construction.

Please ensure that all powder coated articles are masked or covered at this time. It is far easier to prevent accidents than to try and correct them. Should your joinery receive mortar or paint splashes see that these are removed before cure and follow the instructions contained in this brochure.

Typical sticker used to warn other trades of the need to protect and mask off powder coated joinery (applies to anodised joinery also)

"IMPORTANT ALL TRADES"
This valuable aluminium joinery will suffer permanent damage from: plaster, mortar and paint splashes - Protect if splashes occur - Immediately wash down joinery with water or meths - Do not allow splashes to harden! - Do not use solvents! - Do not remove this label until final clean completed.

This photograph display damage that has occurred on site, post installation. The photo of the masked joinery displays clear signs of damage that could have occurred were it not masked. Please ensure that your joinery is protected right through the entire construction process.



Powder Coating Maintenance

External - Maintenance Program:

To extend the life of external powder coated articles and to comply with warranty requirements for powder coated aluminium joinery, a simple, regular maintenance program must be implemented.

The effects of ultra violet light, atmospheric pollution, dirt, grime and airborne salt deposits will all accumulate over time and must be removed or surface staining and weathering will occur, leading to an unsightly appearance.

For external coatings, cleaning should take place every six months. In areas where pollutants are more prevalent, such as beachfront houses and industrial or geothermal areas, then a cleaning program should be carried out on a more frequent basis ie. every one to three months.

Cleaning your powder coating:

1. Carefully remove any loose surface deposits with a wet sponge.
2. Use a soft brush (non abrasive) and a mild household detergent (do not use solvents) in warm water, remove dust, salt and other deposits.
3. Rinse off with clean fresh water.



Restoring weathered or scratched surfaces:

Repair of Scuffed or Scratched surfaces
Dulux Spray Cans are available in all colour card colours.

Repair of Small Scratches or Chips.
Dulux Dabsticks are ideally suited for the repair of small scratches.
Dabsticks may not be available in all colour card colours.

Repair of Weathered areas .
Dulux Gloss Up is a light to medium cutting cream ideally suited for gloss restoration and has been specifically designed for this purpose.
Gloss Up contains no waxes or silicone and is a one step system.



Contact Dulux Powder Coatings , ph 0064 9 441 8244

All pages © Copyright Juralco Aluminium Building Products Ltd, 2023

