

Note:
Where impact noise from pipes is an issue, fix all pipes on resilient brackets.

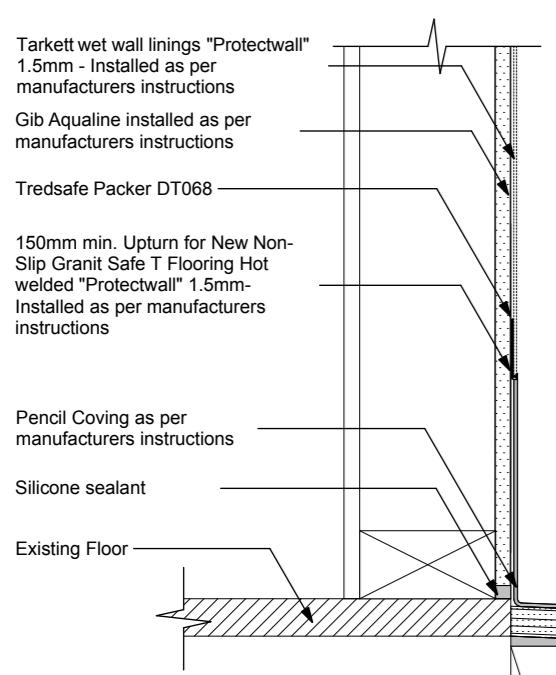

W.A.S Shower Floor to Wall Detail

- TIMBER FLOOR NOTES**
1. Allow to provide New Grade SG8, H3.2 Timber joists under wet area shower
 2. Joists are to be set down 25mm and packed upon to suit fall
 3. Joists Located adjacent to existing joists laminated as per Clause 2.4.4.7 NZS 3604
 4. New Joists sizes to match existing joists
 5. Joists are to be Grade SG8 min. and at 400mm crs. max.
 6. Joists to be supported by and span to bearers at each end

Fixing Sheets
Non-Tiled Areas
'GIB Aqualine' sheets may be installed vertically or horizontally. Sheets are fixed with 'GIB Grabber' screws or; 'GIB® Nails' at 300 mm centres around the perimeter of the sheet, and with 'GIBFix®' adhesive on all intermediate studs and dwangs. Adhesive must not be used under fasteners. A 5-10mm gap must be left between the floor and the bottom of the sheet.

- Fasteners**
- For 10mm GIB Aqualine use minimum 25mm x 6g GIB Grabber Drywall Screws
 - For 13mm GIB Aqualine use minimum 32mm x 6g GIB Grabber Drywall Screws.

- Fastener Centres**
- GIB Grabber Drywall Screws at 100mm centres to perimeter of wall and to all intermediate studs
 - Adhesive is not to be used in place of mechanical fastenings.

GIB Aqualine sheets may be installed vertically or horizontally. Sheets are fixed with GIB® Grabber screws at 100mm centres to perimeter of wall and to all intermediate studs. Adhesive must not be used in place of screws.

Ceilings
Supports of timber or steel battens or ceiling joists must be 450 centres for 10 mm GIB Aqualine, or 600 mm centres for 13 mm GIB Aqualine.

GIB Aqualine sheets must be fixed with GIB Grabber screws at 600 mm centres around perimeter and at 200 mm centre along supports. Alternatively, sheets are screw fixed at 600 mm centres along the supports and GIBFix adhesive fixed at 200 mm centre between.

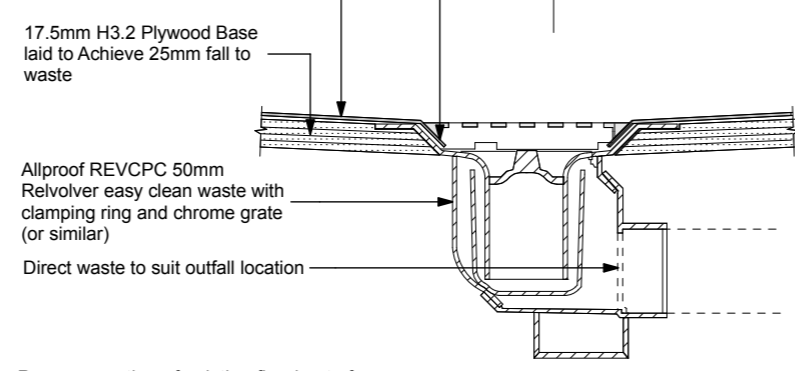
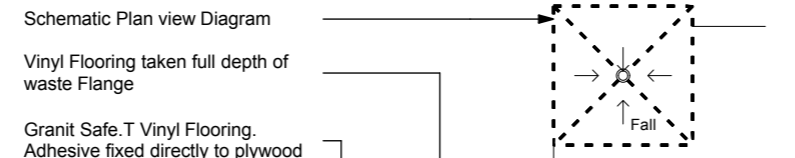

Remove section of existing flooring to form new W.A.S Base

New Shower to have a minimum of 25mm fall to G.T over 1m.

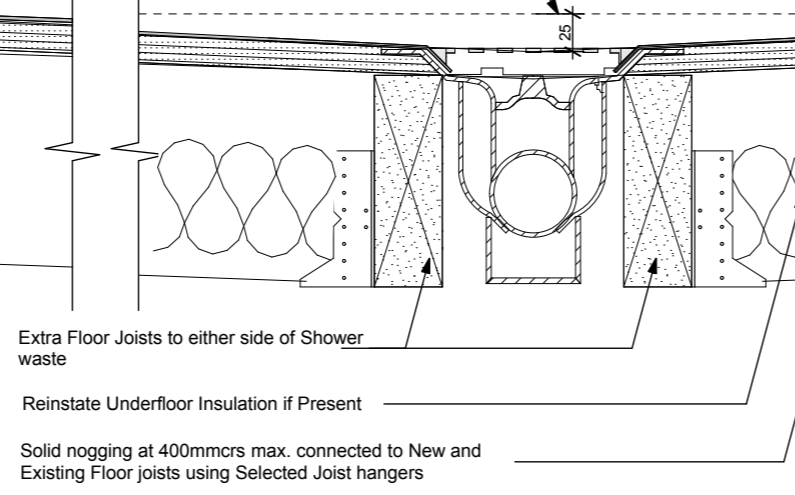

- IMPORTANT!**
- Make sure all specifications and instructions are followed carefully.
 - Contact your Tarkett representative if you are unsure about any part of the installation.
 - Seal Gib Plasterboard linings with Gib-Seal, or one coat Water Based Sealer.
 - Use the same batch number for each continuous surface (if material from several boxes is used, they should have the same manufacturing serial number and be used in consecutive order).
 - Let the flooring acclimatise for a while before laying.
 - The subfloor must be flat, level, clean, without marks (no felt pen, marker, etc.), sound, dry, solid, hard, smooth and not exposed to moisture. Absorbency must be checked.
 - Use only adhesives recommended by Tarkett. Always follow the adhesive manufacturer's instructions.
 - The work must be completed with an inspection: ensure that the newly laid floor is free from adhesive residues.

SUBFLOOR
The subfloor must be level, flat, clean, free from marks (no felt pen, marker of any type, ballpoint pens, paint, etc., that could cause discoloration due to migration) sound, dry, solid, hard, smooth (the absorbency must be checked) and not exposed to moisture. The preparation/dryness of the subfloor and installation procedures should all be in accordance with the current relevant Standard within the country of use. Check with the manufacturer.

LAYING DIRECTION ROLLS
Plan the sheet direction for the area to be installed to ensure whenever possible that joins do not coincide with doorways, main traffic lanes, sinks or urinals. If the room is reasonably square, the sheets should run parallel to the incoming light. In long, narrow rooms it is best to install the sheets along the length of the room. Cut the sheets to length. If coving is necessary, the sheets should be cut longer than the room. All consecutive sheets should be installed in the opposite direction to the previous sheet installed. Butt joint when edges are straight, or overlap the edges by 3 cm and trim the two sheets simultaneously.

GLUING
Glue with an acrylic adhesive emulsion recommended by Tarkett. Apply 250 to 300 g/m2 using a finely serrated trowel.

COVING
Install Pencil coving having a minimum upstand of 150mm and provide Butterfly Mitres into corners following the manufacturers installation instructions.

WELDING
Hot welding is recommended in all areas. Important! Do not weld until the adhesive has bonded completely (wait 24 to 48 hours). Groove the joints using a hand grooving tool or a machine before welding. Weld with hot air and a Tarkett Speed Welding Nozzle or equivalent.

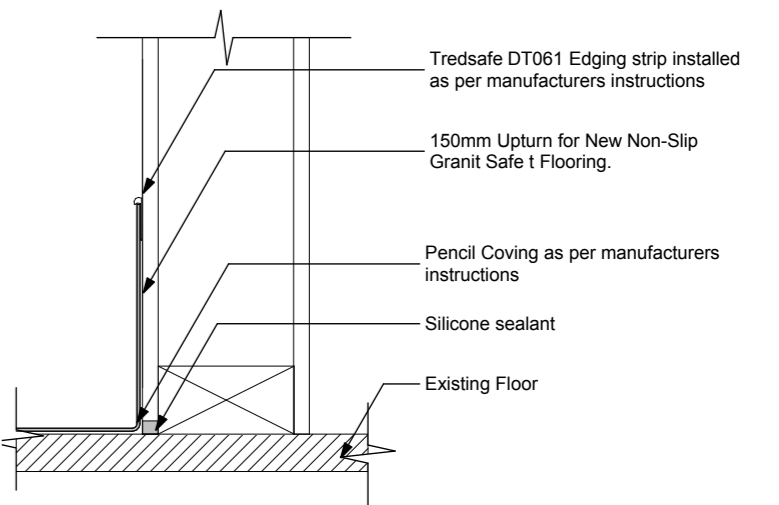
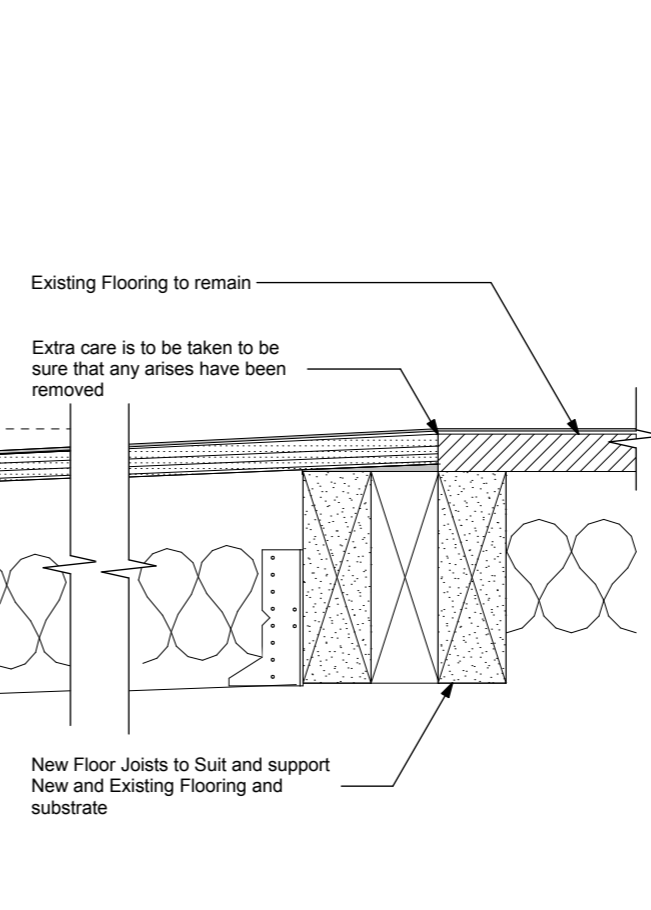

Bathroom (Non wet area) Floor to Wall Detail

Shower enclosures
Shower floors and bases may be constructed with or without upstands, and where installed for use by *people with disabilities* shall have level thresholds.

When enclosures, such as walls, screens, doors or curtains are used they shall be continuous from floor level or top of upstand to 1800 mm minimum above floor level and not less than 300 mm above the shower rose.

Where shower trays are used, the junction between tray and wall linings shall be constructed in accordance with Figure 4 (a) or (b). **Acceptable Solution E3/AS1**

Where the shower floor has no upstand or where a wall, screen, door or curtain is omitted, the floor shall have a fall of no less than 1:50 towards the *floor waste*. The fall shall apply to the floor area within a radius of 1500 mm taken from a point vertically below the shower rose, or from any wall within that radius

