



MEM2400 Series

Mechanical electromagnetic locks



The innovative slimline MEM2400LP Mechanical Electro Magnetic Lock has been designed as an alternative to standard magnetic locks especially suited for situations where door height or narrow profile door frames create installation restrictions and appearance is of paramount importance.

The patented MEM incorporates both magnetic and mechanical design principles to achieve a superior holding force of up to 1000kg, whilst being 75% smaller than a standard 600kg Electro Magnet.

The MEM2400 is capable of opening with up to 70kg side pressure on the door and has the added security function of “Early Warning” alarm condition. The device comes with the FSH patented “Anti-Tamper-Bracket” as standard.



Features

- Slimline design 75% smaller than a standard 600kg magnet
- High holding force up to 1000kg and releases under side load of up to 70kg
- Low power consumption 24 VDC/120mA
- Dual-voltage 12V/24V DC selectable
- Full monitoring lock status sensor (LSS)
- Door status sensor (DSS)
- Early warning alarm (EW)
- Anti-tamper bracket to protect the armature plates fixing bolt

Warranties

Mechanical	5 years
Finish	allegion.co.nz/finisheswarranty
Electronic	1 year

Technical specifications

Model	MEM2400LP
Light Feature	Light panel (LP)
Function	Surface mount, outward opening doors
Holding Strength	Up to 1000kg
Voltage / Current	Dual voltage 12/24 VDC 12 VDC/240mA 24 VDC/12mA
Monitoring	EW / LSS / DSS
Dimensions	MEM = 158mm (W) X 35mm (H) x 30mm (D) Armature plate = 120mm (W) x 30.6mm (H) x 12.5mm (D) Anti-tamper bracket = 194mm (W) x 38mm (H) x 30mm (D)

Mounting details

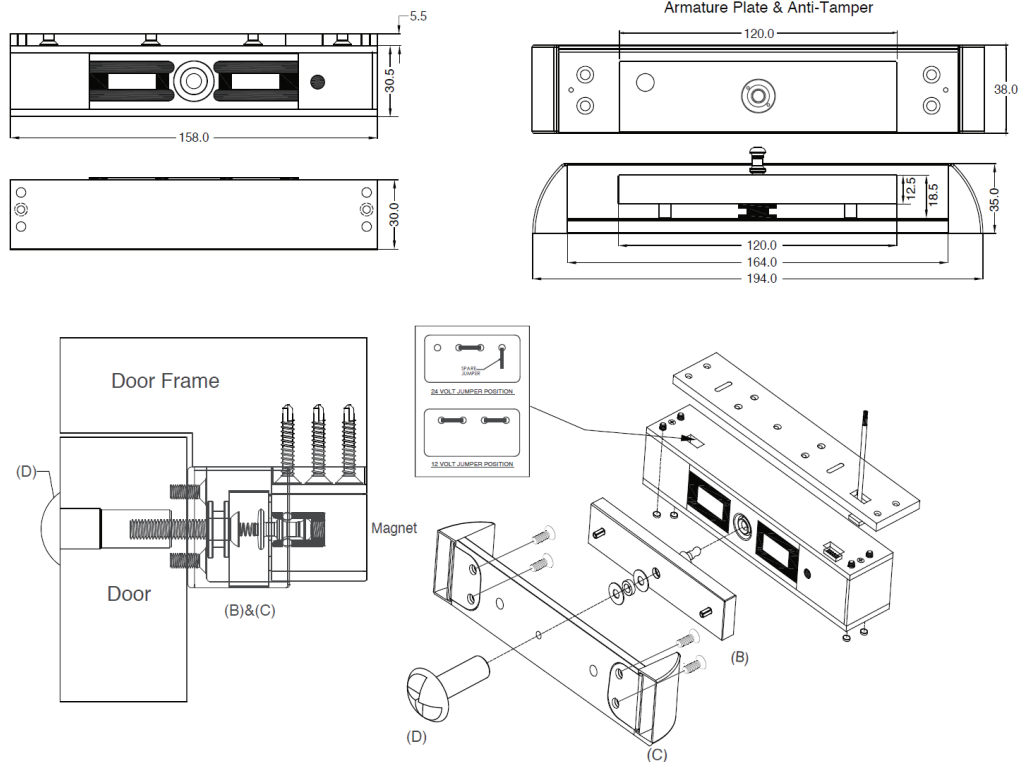

Testing and Compliance



Fire:
Tested to 4 hours on fire door assemblies as specified in AS/NZ 1905.1 – 1997 Part 1 Fire Resistant Doorsets

Accessories

MEM2400L Adjustable L-Bracket for Narrow Header Frames

