



Code **HK 100 N**

Material Casing:#304 Satin Stainless Steel, 1.2mm Thickness
Motor 200W Brush Type: Dual Ball Bearings, 7500 RPM
 105°C auto resetting safety overload thermostat

Power Use 240V, 50Hz, 2000W, 9.2A

Sound Level 70db (+/- 3)

Drying Time Less than 15 seconds

Drip Proof Rating IPX 1

Heater Element 2000W

Heater Assembly 87°C auto resetting thermostat
 141°C auto resetting safety thermal cut off

Warm Air Speed 10.8m/s

Warm Air Temp Ambient +20°C

Timing Protection 60 seconds power safety cut off - auto reset

Timing Duration 2 second delay turn off after last read

Sensor/Range Infrared Automatic - 180mm +/-20mm preset
 100 - 300mm adjustable distance

Casing Security 2 SS theft resistant hex drive screws (hex key supplied)

Net Weight 6.0kg

Dimensions 268mmW x 273mmH x 100mmD

Note Unit can be hard wired by electrician or used with cord and plug provided
 Installation template & instructions included



Slimline Auto Operation Hand Dryer

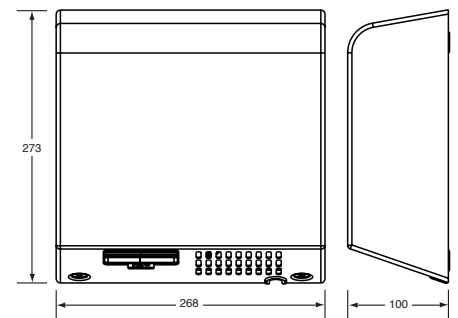

Code **HK 2200 SA (F)**

Material Casing:#304 Satin Stainless Steel, 1.2mm Thickness
 Nozzle: Diecast Zinc, Chrome Plated

Motor 100W Brushless, 2850 RPM
 105°C auto resetting safety overload thermostat

Power Use 240V, 50Hz, 2200W, 9.17A

Sound Level 64db (+/- 3)

Drying Time 25-30 seconds

Drip Proof Rating IPX 1

Heater Assembly 87°C auto resetting thermostat
 142°C auto resetting safety thermal cut off

Warm Air Speed 14.5m/s

Warm Air Temp Ambient +30°C

Timing Protection 60 seconds power safety cut off - auto reset

Sensor/Range Infrared Automatic - 180mm +/-20mm preset
 100 - 300mm adjustable distance

Casing Security 2 SS theft resistant hex drive screws (hex key supplied)

Net Weight 6.1kg

Dimensions 320mmW x 220mmH x 175mmD

Note Unit can be hard wired by electrician or used with cord and plug provided
 Installation template & instructions included



Auto Operation Hand Dryer

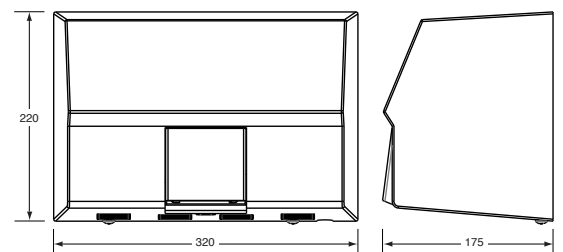

Specify **HK 2200 SS (F) - Push Button Operation**

Same as above except Push Button Operation



The photographs and line drawings of the products in this catalogue are representational only. Metlam Australia Pty Ltd reserves the right to, and from time to time, make changes and improvements in design and dimensions.