

dbBatten™

Acoustic Battens



Product overview

dbBatten™ range is a modular acoustic batten designed for function with modern aesthetic. It is suitable to be installed direct to both ceiling and wall via our patent-pending, glue-free and DIY Ready-Clip™ install system.

Made from 100% polyester fibre, of up to 60% recycled content, dbBattens are light weight and non-irritant, can be direct fixed or rafted and suspended for exceptional sound absorption. As well as being simple to install, dbBatten can be removed and re-purposed with minimal fuss, reducing waste and improving the sustainability of interior finishes.

Available in two standard lengths, or we can custom size to suit your space and design. We can print texture, wood-grain, custom block colour or pattern directly to the batten.

dbBatten™ with Ready-Clip™ is your smart acoustic solution.

Benefits

Precise installation

Our dbBatten™ acoustic battens come with everything needed for installation, including installation guide for easy alignment of battens and fixing locations

Better spaces

Improved acoustics: Audibly reduces reverberation time

Visual impact: A variety of available material colours offering ~78% light reflectance. Panels can be subtle or a feature design. Ask us about customisation

Future proofing

Durable panel construction with high impact resistance provides long-term stability and performance

CUSTOMISATIONS



Custom prints



Ready Clip™ system



CNC cut

dbBatten™

Acoustic Battens

2230mm

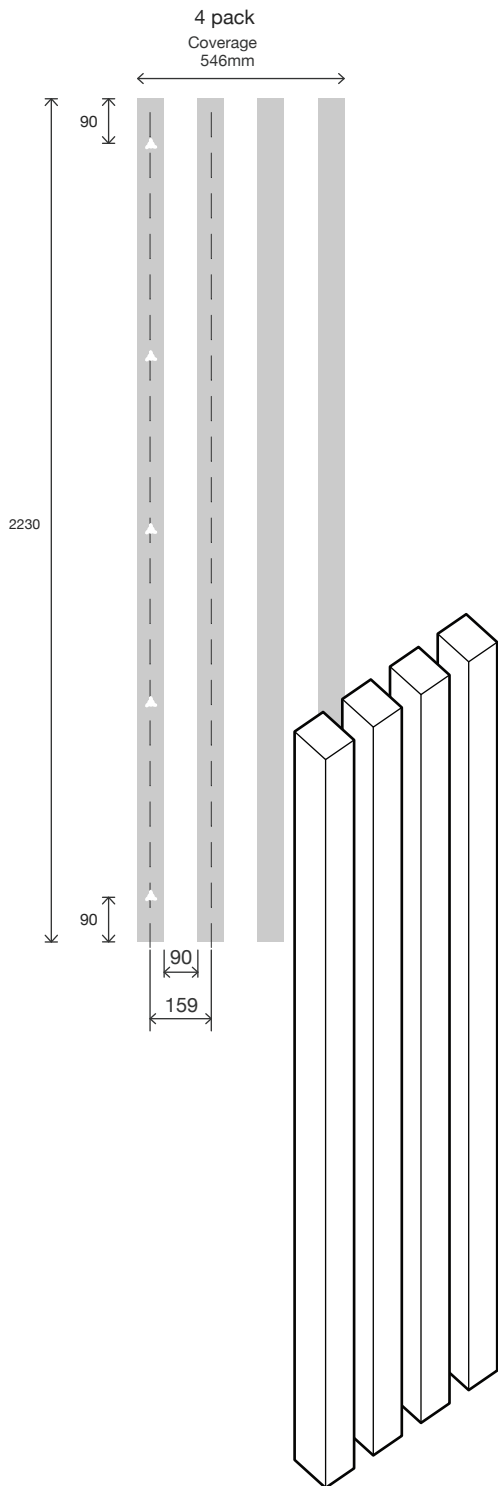

1030mm

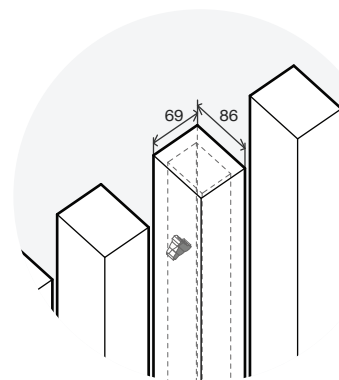
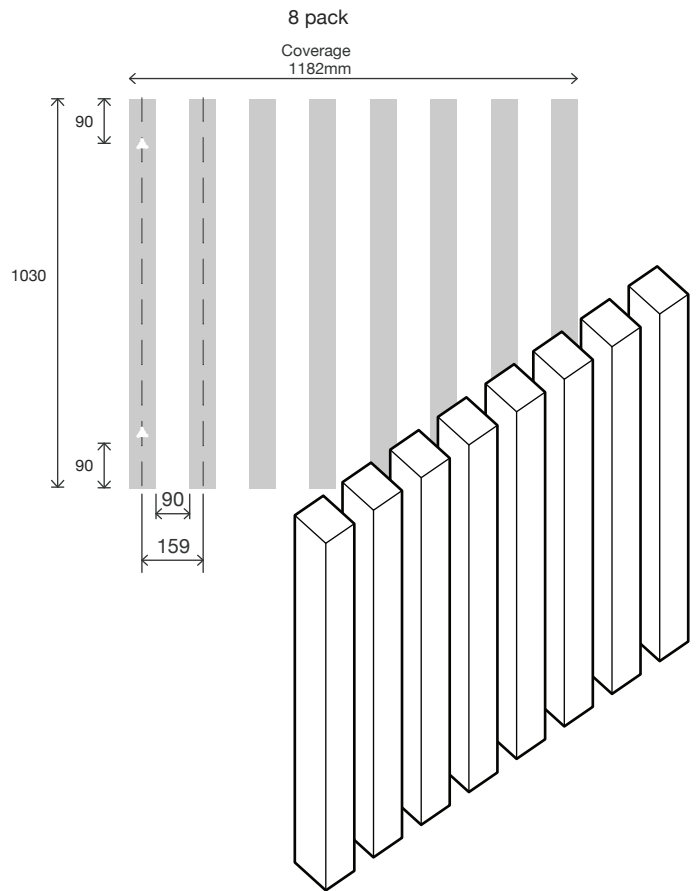

Ready-Clip™

Standard colours

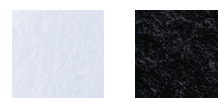

Alpine Onyx

Custom colours available



DBSORB Ltd Acoustic Systems
 Phone: (+64) 09 553 6775
 Email: sales@dbSORB.co.nz www.dbSORB.co.nz
 Address: 91b Morrin Rd, St. Johns, Auckland 1072
 Copyright © 2022 DBSORB Ltd
 All Rights Reserved



dbBatten™

Acoustic Battens

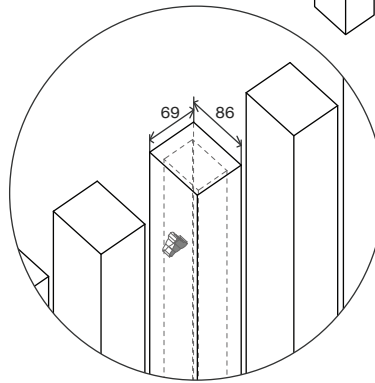
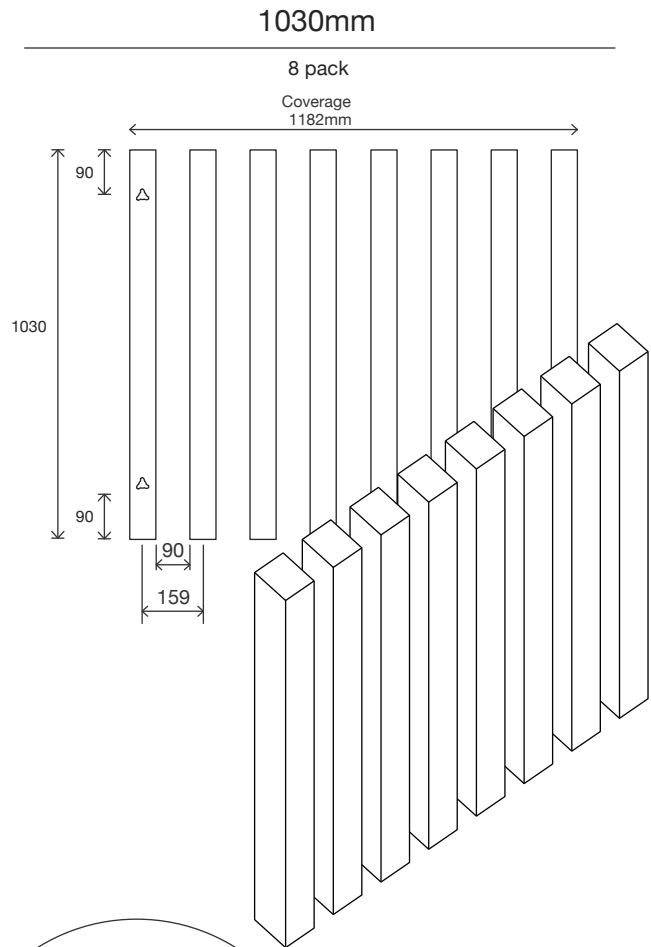
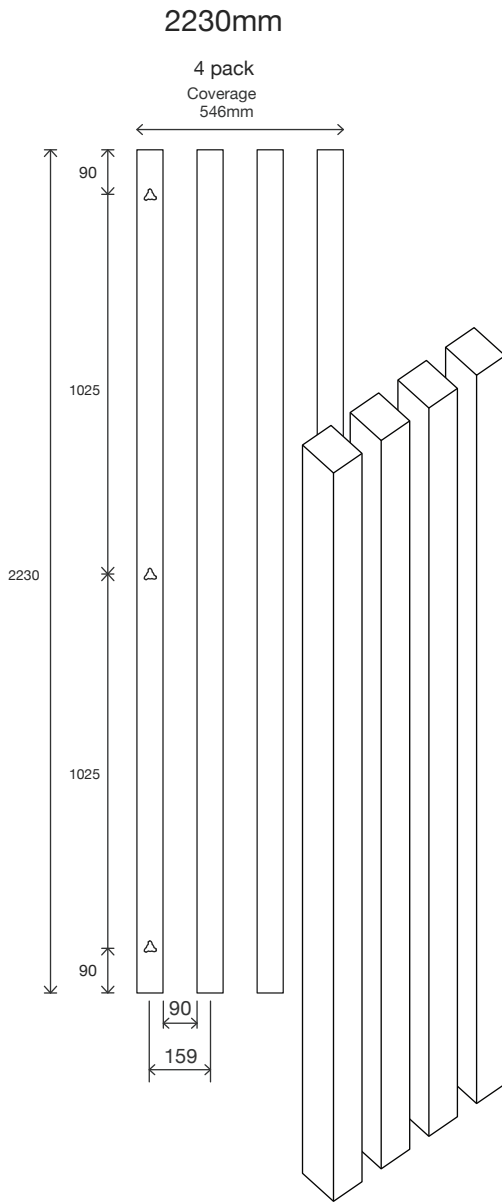

Ready-Clip™

Standard colours



Alpine



Onyx



DBSORB Ltd Acoustic Systems
 Phone: (+64) 09 553 6775
 Email: sales@dbsorb.co.nz www.dbsorb.co.nz
 Address: 91b Morrin Rd, St. Johns, Auckland 1072
 Copyright © 2022 DBSORB Ltd
 All Rights Reserved



NRC 1.05



Composition:
100% PET (up to 60% recycled content)



No loose fibres



Antibacterial



Made in NZ
Non-toxic, Non irritant
Glue free, Low VOC



Ready Clip™ system