

# Cloud™

## Suspended Decorative Baffle



### Product overview

Dbsorbs Cloud™ range of suspended baffle installations create a modern aesthetic with excellent acoustic performance. The Cloud installations are designed to effectively reduce reverberation across a broad range of frequency.

Our Cloud baffle includes an adjustable suspension kit, requiring minimal assembly for installation that allows it to be suspended at a range of heights.

The Cloud baffle can be used to mask services above, as a cloud-like feature in open spaces, or to effectively position over large desks and work spaces.

### Applications

Ceiling & Wall:  
Office Interiors, Showrooms, Hospitality, Education and Residential.



Composition:  
100% PET (up to 60% recycled content)



Fire rating 24mm:  
ASTM E-84-17: Class A, FS:5 - SD:65  
EN 13501-1:2007+A1:2009: B - s1, d0



No loose fibres



Antibacterial



Environmental:  
Global Recycled Standard (GRS) 4.0  
OEKO-TEX® Confidence In Textiles – STANDARD 100  
Tested for harmful substances Annex 6\*  
Low VOC

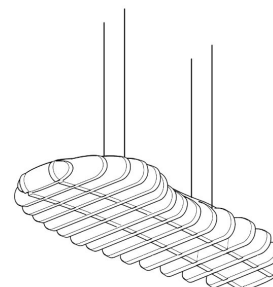
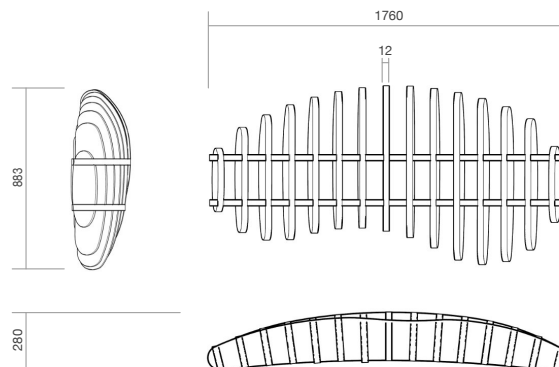

DBSORB Ltd Acoustic Systems  
Phone: (+64) 09 553 6775  
Email: sales@dbsorb.co.nz www.dbsorb.co.nz  
Address: 91b Morrin Rd, St. Johns, Auckland 1072  
Copyright © 2022 DBSORB Ltd  
All Rights Reserved