



**PROMASTOP® UniCollar®**  
**Plastic Pipe & Other Services Penetration Seals**



[www.promat-ap.com](http://www.promat-ap.com)

Solely for distribution in New Zealand



PROMASTOP® UniCollars® are a fire stopping device containing intumescent material designed to maintain the integrity of the fire resistant element through which plastic pipes pass. The collars are suitable for installation in various floors and walls similar to that in which they have been tested.

In the event of a fire, the intumescent material in PROMASTOP® UniCollar® rapidly expands, closing off the plastic pipe or combustible insulation and forming an insulating barrier. This intumescent compound continues to expand throughout the fire and forms a non combustible char which stops the fire passing into adjacent fire compartments.

However, it is important to note that there are many different kinds of plastic and they react to fire in different ways. This means that fire collars may have to be tested on many types and sizes of pipe. Please note that local regulations must be accurately assessed if this is appropriate or necessary. Examples of plastic pipes are uPVC, HDPE, PP, PPR, ABS, PE and Pex/Al/Pex.

At time of this publication, there is no British Standard covering this specific section of fire stopping. Nevertheless, the general conditions of BS 476: Part 20: 1987 are used to evaluate penetration seals.

Australian Standard AS 4072: Part 1: 2005 "Components for the protection of openings in fire resistant separating elements. Part 1: service penetrations and joints" calls for all types of plastic pipe and all sizes to be tested. This means that any assessments written to AS 4072: Part 1: 2005 must be able to refer to tested specimens that clearly show the type of plastic has been tested with the collar in the same orientation and size as to be used in practise.

It is currently acceptable to test new types of plastic using uPVC as a benchmark.

PROMASTOP® UniCollar® has undergone fire tests in numerous countries around the world to many standards. Please contact Promat to check if the approval of the required application is already covered.

## Packaging

PROMASTOP® UniCollar® is packaged in individual boxes each containing 2250mm length of collar or 150 segments. The collar is designed so that it can be cut and snapped in modules of 15mm.

One box contains the equivalent of 5 x 110mm collars. Please see table below for a usage guide to the approximate number of collars and brackets each full length of PROMASTOP® UniCollar® equates to in most typical on-site applications.

The table shows the suggested lengths of collar (segments) required for various inside diameters (I/D) of plastic pipes. In difficult situations it may be necessary to use longer lengths of collar to assist with installation.

The number of collar units per box may vary depending on installer's skill and attention to detail.

At time of this publication, tests have not been carried out on plastic pipes greater than 200mm outside diameter. Please consult Promat for details of such applications.

For uPVC pipes with 110mm outside diameter or less, add two segments if the collar has to fit around a pipe joiner.

## Dimension

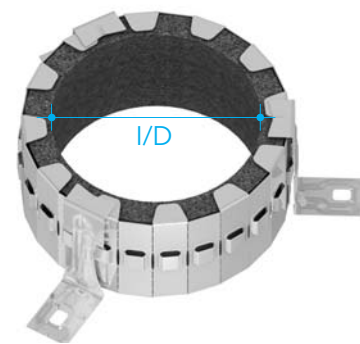

## Usage guide

Inside diameter mm (I/D) inches	43	50	55	63	69	75	83	90	110	114	125	140	160	200
Segments per collar (UL listing if featured)	15	17	18	20 (19)	21	22	24	25	29	30	33	36	40 (42)	49
Approximate number of collars per box	10	8.5	8	7.5	7	6.5	6	6	5	5	4.5	4	3.5 (3.75)	3
Number of brackets per collar for floor application	2	2	2	2	2	3	3	3	3	3	4	5	5	5
Number of brackets per collar for wall application	2	2	2	2	2	3	3	3	3	3	3	5	5	5

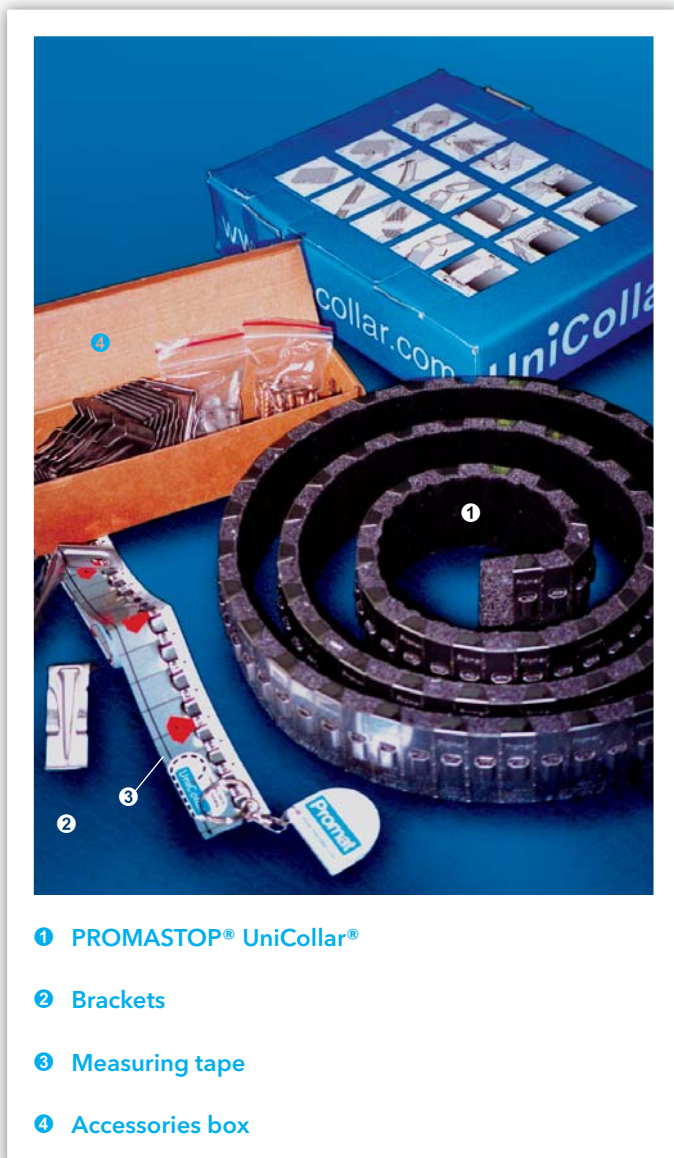

- 1 PROMASTOP® UniCollar®
- 2 Brackets
- 3 Measuring tape
- 4 Accessories box

## Removing casing and accessories

Each package of PROMASTOP® UniCollar® contains the fixings and other accessories required for installation (see pictures on [page 4](#)).

Please read the information in this manual in conjunction with the diagrams printed on the rear of the package and use of the measuring tape provided as an accessory in the package:

- Open the package at the position clearly marked with an arrow.
- Remove the accessories box before pulling out one end of the PROMASTOP® UniCollar®. The collar strip will uncoil.
- Ensure the soft Graftex side of the collar strip faces up. The steel has perforations to ease the snapping of the length located at 15mm centres.
- Use only sufficient length (segments) required of the collar from the package. For example, approximately 600mm of a segment pulled out is adequate and convenient for a 110mm cut of the collar.

## Cutting/snapping the collar

- Correctly identify the required outside diameter of the plastic pipes to which the PROMASTOP® UniCollar® will be applied. The diagrams printed on the package provide concise information on the number of segments required for various sizes of plastic pipes.
- Either count the number of the 15mm segments required or measure the collar strip using the tape provided. One side of the measuring tape is marked with each pipe size. The correct number of segments and directions are clearly indicated on the other side of the tape.
- Hold the measuring tape on the collar strip and align both ends of the tape and the strip.
- Cut through the soft Graftex side of the collar strip at an appropriate position, e.g. cut at segment 29 for a 110mm outside diameter pipe. It is important to note that, for safety purpose, the strip should be cut in an opposite direction from fingers at all times and this exercise should be performed in a consistent manner.
- Hold the collar strip between finger and thumb on each side and as close as possible to the desired cut section. Fold in a downward direction as far as possible. The cut Graftex will open. Repeat the folding and unfolding sequence until the steel snaps.

## Assemble the collar

- Both cut ends of the Graftex should be square. For easier fixing, cut these square ends to a slight angle. Shape the cut collar section (casing) to the approximate outside diameter of the plastic pipe. For small pipes (e.g. < 75mm), pay attention to the square ends of these casings to ensure they have been shaped correctly.
- Push one of the prongs of a bracket through the notch at one end of the casing. Fold the casing around the plastic pipe and push the other prong through the notch at the other end of the casing. If pushing is difficult, the bracket can be gently hammered into position. Attach this bracket followed by others onto the floor/wall.

If it is difficult to position the first bracket, additional bracket(s) can be positioned against the strip casing. The correct number of brackets must be used and both ends of the casing must be connected with one bracket. The prongs of all brackets must be fully engaged through the notch on the casing, i.e. the prong should go in one side and out from the other side, and does not get caught inside the casing.

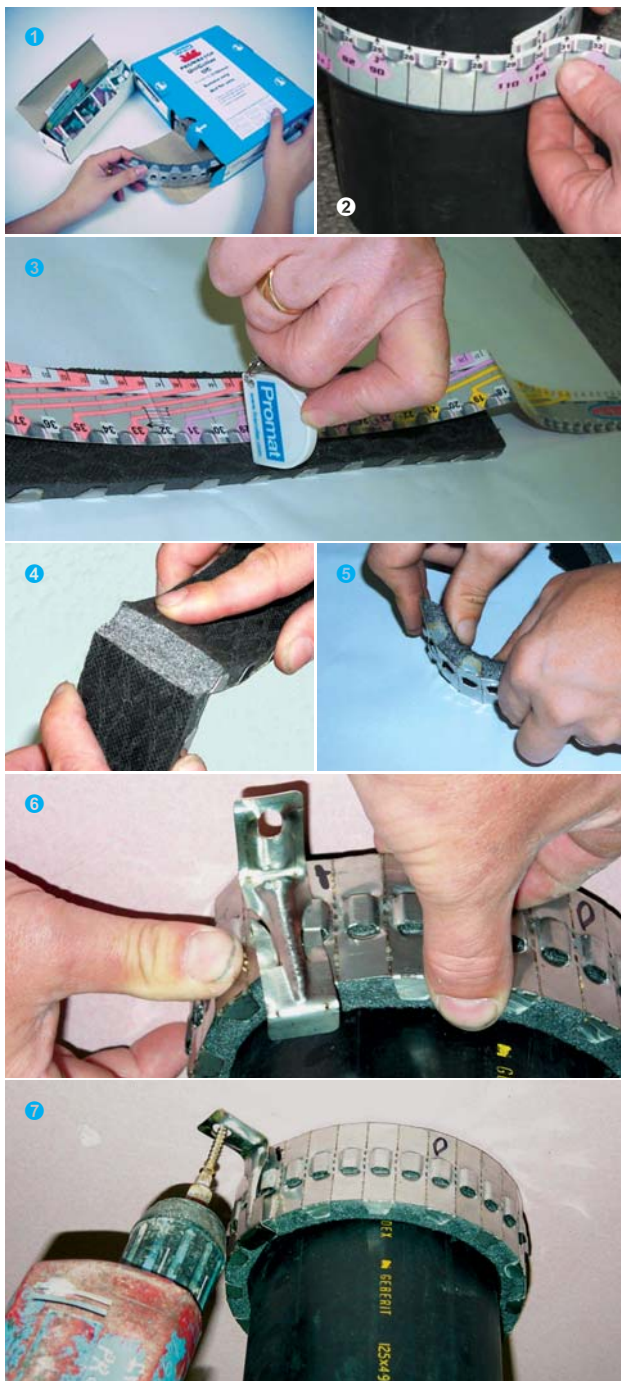

- 1 Pull out the PROMASTOP® UniCollar® strip and accessories box
- 2 Identify outside diameter of the plastic pipe using the measuring tape provided
- 3 Place the measuring tape on the soft Grafitex side of the collar strip and cut the Grafitex strip
- 4 Bend and snap the collar strip accordingly
- 5 Shape the cut collar section (casing) to suit the pipe
- 6 Fit the casing around the pipe with one bracket first to joint ends
- 7 Attach other brackets onto the floor/wall

## Plastic pipe penetration seals

### Retrofit installation to underside of floors

PROMASTOP® UniCollar® has been tested up to 240 minute fire resistance with various plastic pipes up to 200mm outside diameter when fixed to soffit of concrete/masonry floors (with an equal or greater fire resistance level) through the provided brackets using 20mm x 5mm steel bolt anchors, on condition that the floor is in a secure condition for holding the anchors.

Backfill all annular gaps greater than 8mm between the plastic pipe and the floor with PROMASEAL® Mortar or other commercial grade mortar mix. A suitable water resistant sealant (e.g. PROMASEAL® Supa Mastic) may be applied around the pipe on top side of the floor if a water seal is required.

If the gap is less than 8mm, apply a bead of PROMASEAL®-A Acrylic Sealant approximately 8mm deep into the gap on underside of the floor.

### Retrofit installation to both sides of walls/partitions

PROMASTOP® UniCollar® has been tested up to 240 minute fire resistance with various plastic pipes up to 200mm outside diameter, depending on types and sizes of the pipes using the recommended number of the provided brackets.

For concrete/masonry walls, use the 20mm x 5mm steel bolt anchors provided. For steel/timber framed lightweight partitions, use 40mm x 10g laminating screws provided. The walls or partitions must be in a secure condition that will hold the anchors.

All annular gaps between the pipe and the walls/partitions must be minimum 2mm and filled with a bead of PROMASEAL®-A Acrylic Sealant.

Please consult Promat for details of PROMASTOP® UniCollar® retrofit installation to underside of floors and both sides of walls/partitions. For complete UL listing to these applications, please visit <http://www.ul.com>.

## Other Services Penetration Seals

### Retrofit installation to concrete/masonry floors

Position PROMASTOP® UniCollar® around the services and fix to the underside of the slab in the same manner as fitting for plastic pipes. Then fill any gaps inside the collar caused by the orientation of the service with PROMASEAL® Grafitex. Size of services should not exceed the inside diameter of the 100mm collar.

### Retrofit installation to plasterboard walls

Position PROMASTOP® UniCollar® around the services and fix to the wall in the same manner as fitting for plastic pipes. Then fill any gaps inside the collar caused by the orientation of the service with PROMASEAL® Grafitex. Size of services should not exceed the inside diameter of the 100mm collar.

Up to -/240/240 fire resistance in accordance with the requirements of BS 476: Part 20: 1987 and AS 1530: Part 4: 2005; insulation criteria will vary depending on type and size of plastic pipes AND the type of penetrating elements, OR

Up to -/120/120 fire resistance in accordance with the requirements of BS 476: Part 20: 1987, AS 1530: Part 4: 2005 and/or AS 4072: Part 1: 2005; insulation criteria will vary depending on type and size of building services AND the type of penetrating elements

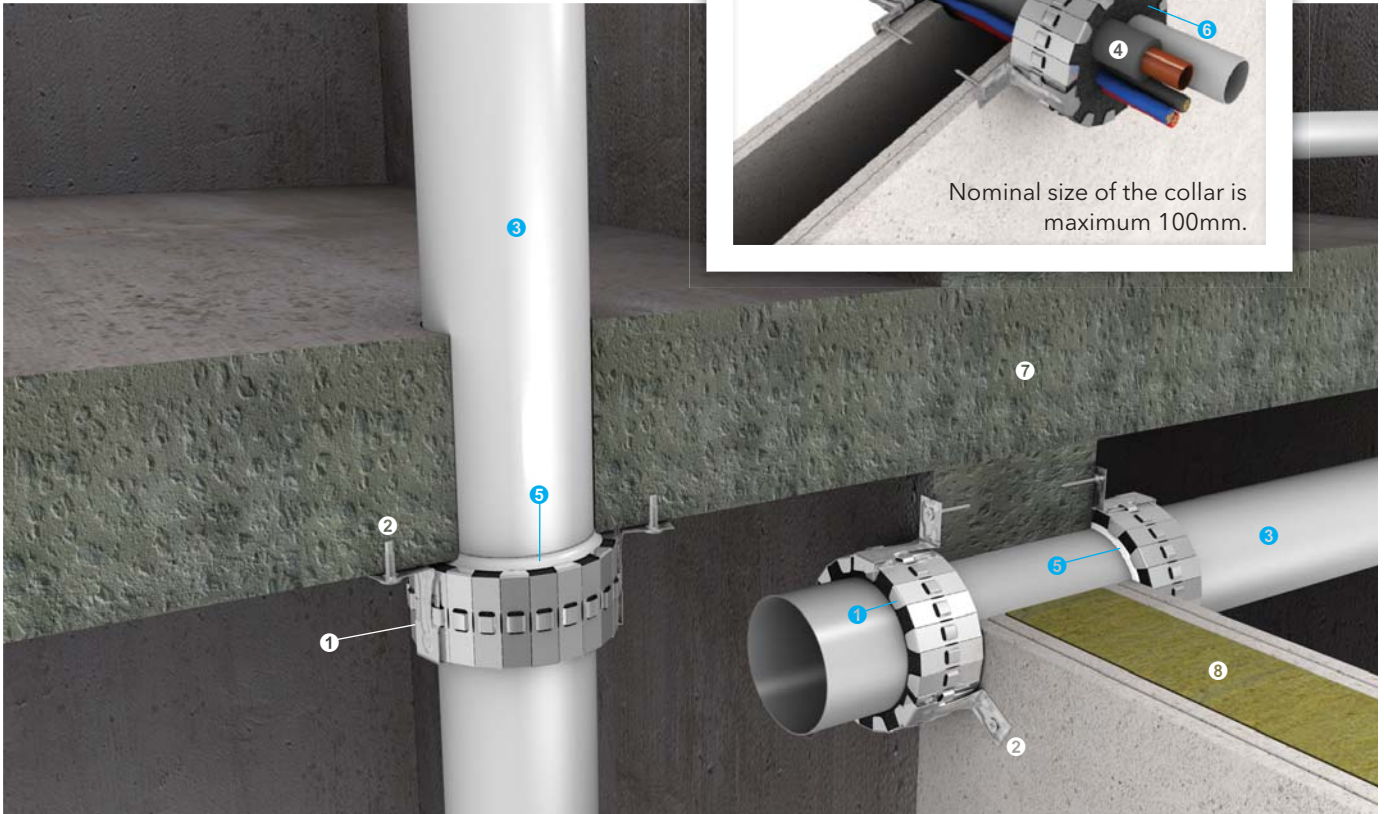
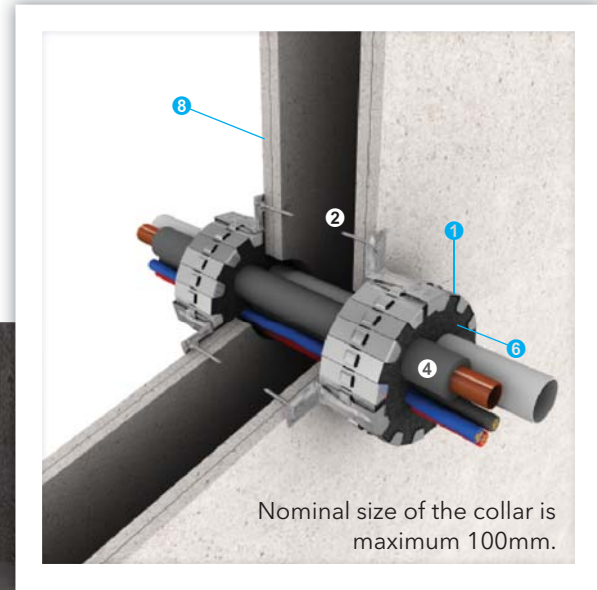

- ① PROMASTOP® UniCollar®
- ② Brackets attached with suitable fixing, i.e. steel bolt anchors for masonry/concrete floors and walls OR laminating screws for lightweight partitions
- ③ Various plastic piping
- ④ Various building services, e.g. electrical cables, plastic (uPVC or PEX) pipes and/or insulated copper pipes
- ⑤ All gaps caulked with PROMASEAL®-A Acrylic Sealant to achieve the required fire resistance performance
- ⑥ All gaps between collars and services filled with PROMASEAL® Grafitex
- ⑦ Fire resistant concrete/masonry floors or walls
- ⑧ Fire resistant steel/timber framed lightweight partitions

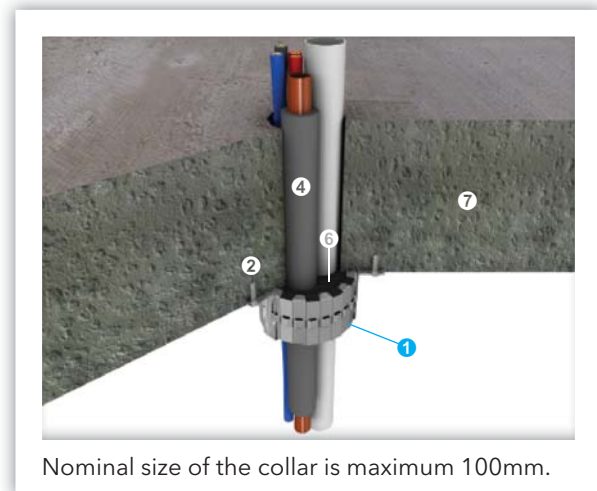

Promat provides a wide range of systems for compartmentation, fire resistant air and cable ducts, structural steel protection, fire stopping and partitions. For assistance with any passive fire protection problems, contact the nearest Promat office.

## Promat Australia Pty Ltd

1 Scotland Road  
Mile End South, SA 5031  
T 1800 PROMAT (776 628)  
F +61 (8) 8352 1014  
E mail@promat.com.au

## New South Wales Office

Unit 1, 175 Briens Road  
Northmead, NSW 2152  
T 1800 PROMAT (776 628)  
F +61 (2) 9630 0258  
E mail@promat.com.au

## Victoria Office

Suite 205, 198 Harbour Esplanade  
Docklands, VIC 3008  
T 1800 PROMAT (776 628)  
F 1800 334 598  
E mail@promat.com.au

## Queensland Office

1/68 Lisgar Street  
Virginia, QLD 4014  
T 1800 011 376  
F 1800 334 598  
E mail@promat.com.au

- The technical data provided in this publication is based on mean values prevalent at time of publication and is thus subject to fluctuation. It should not be regarded as a guarantee to system performance.
- All data contained herein conforms to and frequently surpasses generally accepted fire protection standards recognised by most professional fire science practitioners and regulatory authorities worldwide. The same general principle is equally applicable to all Promat products and systems. Promat has access to a considerable body of test authentication data and this can be provided on a complimentary basis upon request. It should be noted however that this publication replaces all previous editions in its entirety. Any form of reproduction by any means – manual, electronic, digital or otherwise – is strictly prohibited and subject to prior approval in writing from Promat. All rights related or connected to the Promat logo, Promat registered trademarks, featured illustrations, written information and technical reports in this publication are the sole, exclusive and copyright property of Promat and its legal partner companies.

## Your local Promat supplier



[www.forman.co.nz](http://www.forman.co.nz)

Toll Free Number 0800 45 4000

Promat Asia Pacific organisation

[www.promat-ap.com](http://www.promat-ap.com)

• Australia • China • Hong Kong • India • Malaysia • Singapore • South Korea

an **etex** company