

A modern office interior featuring a ceiling with wooden slat baffles. The office has cubicles with wooden desks and partitions, and large windows in the background. The lighting is warm and focused on the workstations.

ARMSTRONG
METALWORKS®
BAFFLES

Inspiring Great Spaces®

Armstrong®
CEILING SOLUTIONS

ARMSTRONG METALWORKS® BAFFLES

Create exciting linear
visuals with Armstrong
MetalWorks® Baffles

THE CRAFTSMAN

Eighty-two years of experience, eighty hand-held processes,
one piece of leather.



R.M. Williams

BENEFITS

- A multitude of design options using standard or custom profiles, lengths, finishes, modules and configurations, limited only by imagination
- Attractive linear ceiling system that screens the open plenum
- Fast and easy installation
- Durable extruded aluminium Baffle profiles
- Heavy duty U-Profile Suspension Channel
- Extensive range of colour options, including Wood Effects
- Simple "end to end" Baffle connection or terminate with standard End Caps

APPLICATION AREAS

- Open plan spaces
- Foyers / lobbies
- Reception areas
- Airports / Transport terminals
- Waiting areas
- Meeting rooms
- Restaurants

Project: Brisbane International Airport
Product: MetalWorks Narrow Baffles – Satin White

Front Cover Project: Deakin Downtown – Melbourne, VIC
Product: MetalWorks Tube Baffles – American Oak with black R-H 200 Hook On acoustic infill panels

COLOUR OPTIONS



Other colours
available upon
request

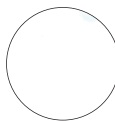

Satin White



Black



Light Bamboo



Dark Bamboo

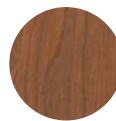

Walnut

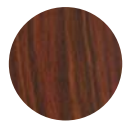

Dark Walnut

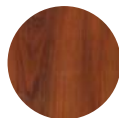

Cherry



Dark Cherry

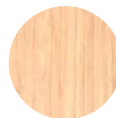

Light Maple

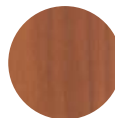

Maple



Oak



Cabreuva



Prado

BAFFLE PROFILE SOLUTIONS

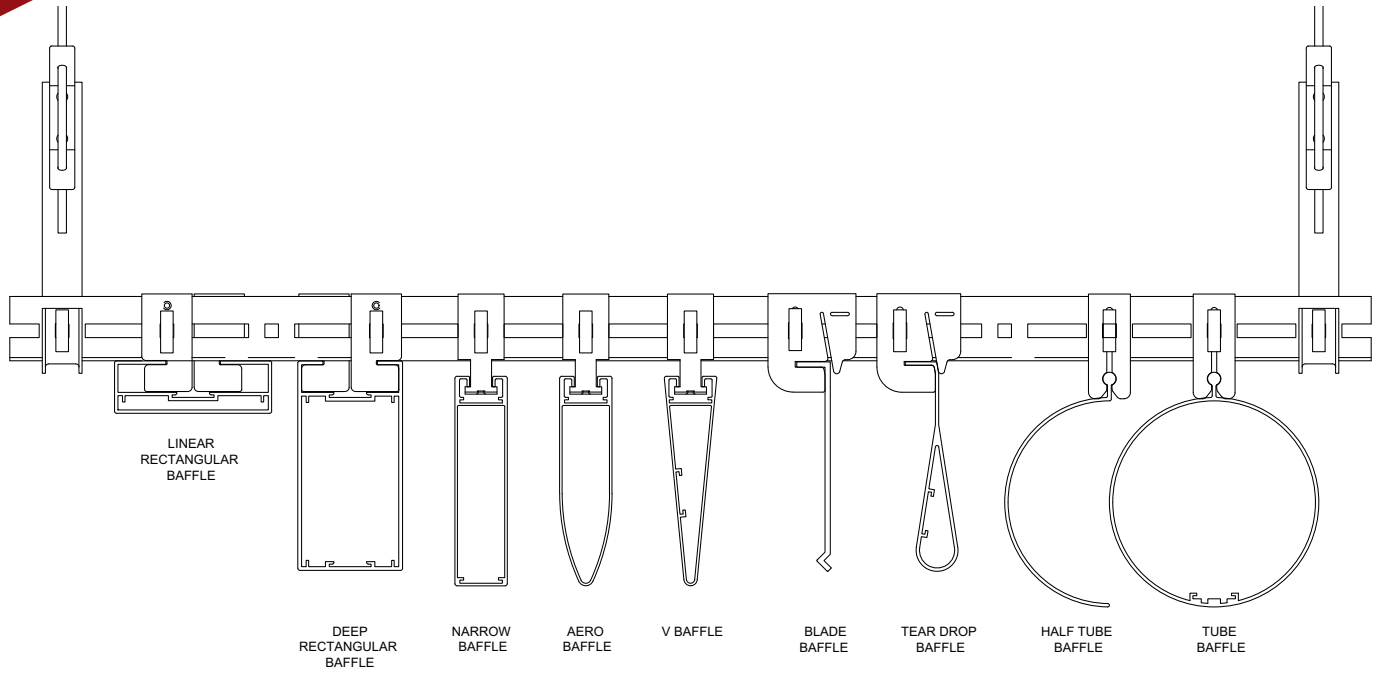

Linear Rectangular Baffle		Deep Rectangular Baffle		Narrow Baffle		Aero Baffle	V Baffle	Blade Baffle	Tear Drop Baffle	Half Tube Baffle	Tube Baffle
Depth	Width	Depth	Width	Depth	Width	Depth	Depth	Depth	Depth	Diameter	Diameter
25	50, 75, 100	100	50, 75, 100	100	25	100	100	100	100	50	50
50	50, 75, 100	150	50, 75, 100	150	25	150	150	150	150	75	75
75	50, 75, 100	200	50, 75, 100	200	25					100	100
		250	50, 75, 100								
		300	50, 75, 100								

Note: All dimensions in mm

Specification: Armstrong MetalWorks® (Linear / Deep / Narrow Rectangles, V, Blade, Tear Drop, Half Tube, Tube) Baffles Ceiling System with concealed U-Profile Suspension System

Baffle Material: Extruded Aluminium

Surface Finish: Powdercoated Satin White or Black, with custom colours and Wood Effects available

Edge Detail: Square Edge, with End Caps available, or connected with Baffle Joiner

Module Sizes: Baffles to be installed as per specification, with spacing dependant on profile and at 25mm increments along U-Profile Acoustic Infil Solutions available

System Weight: Varies based on Baffle profile

Service Integration: Refer to Installation Guide

- Contact your Armstrong Ceilings Representative for stock availability
- Other profiles and sizes available upon request. Minimum order quantity may apply



Conforms with BCA Spec.
C1.10 and tested to AS/NZS
3837:1998 – Group 1,
ISO 5660 – Group 1–S



Humidity
Resistance
RH99%



SUSPENSION SYSTEM AND COMPONENTS

Baffle Installation with U-Profile Suspension Channel

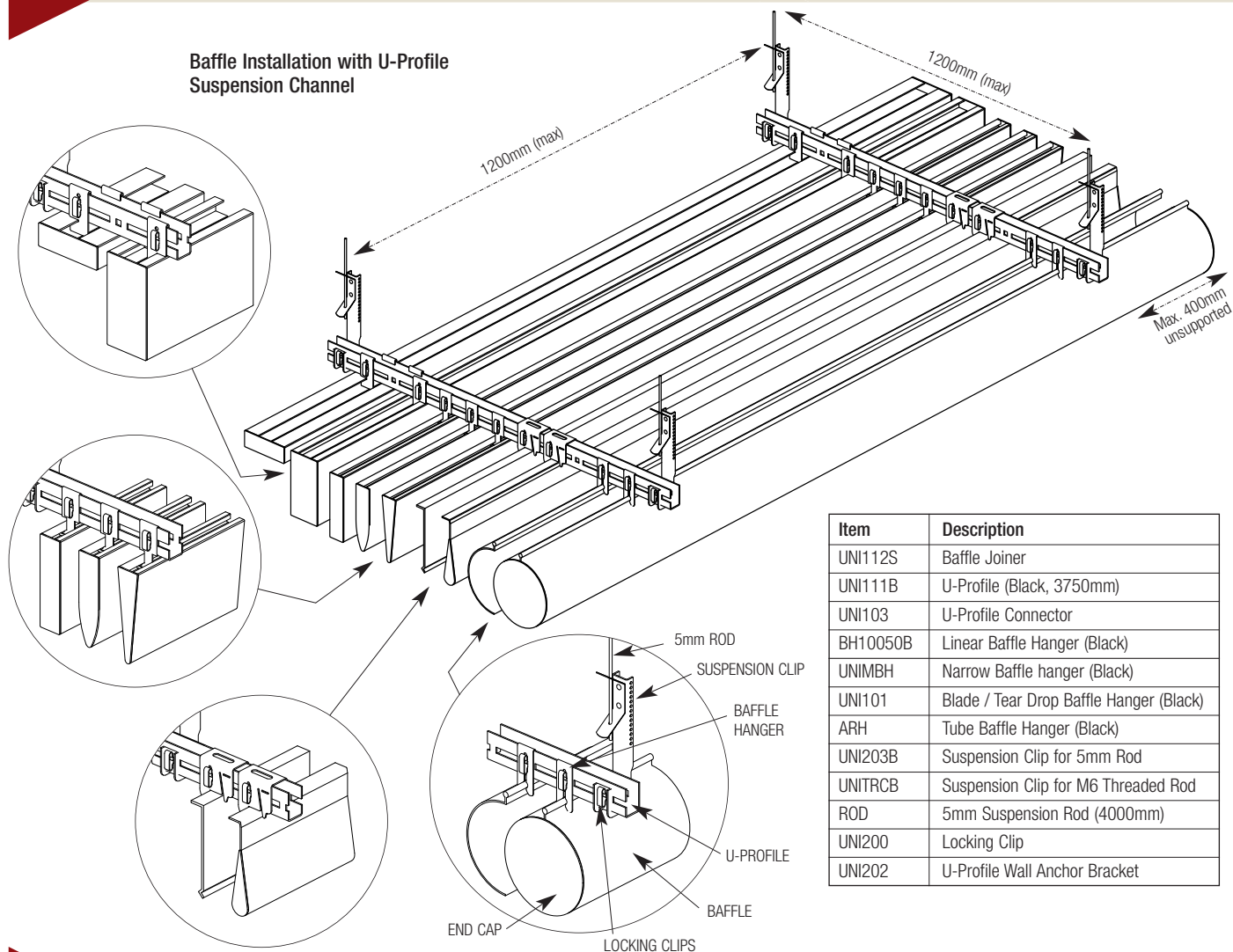

Item	Description
UNI112S	Baffle Joiner
UNI111B	U-Profile (Black, 3750mm)
UNI103	U-Profile Connector
BH10050B	Linear Baffle Hanger (Black)
UNIMBH	Narrow Baffle hanger (Black)
UNI101	Blade / Tear Drop Baffle Hanger (Black)
ARH	Tube Baffle Hanger (Black)
UNI203B	Suspension Clip for 5mm Rod
UNITRCB	Suspension Clip for M6 Threaded Rod
ROD	5mm Suspension Rod (4000mm)
UNI200	Locking Clip
UNI202	U-Profile Wall Anchor Bracket

CONTACT

Armstrong World Industries Pty Ltd

NSW/ACT

Armstrong World Industries Pty. Ltd.
Unit 4, 1 Basalt Road, Pemulwuy NSW 2145
Telephone (02) 9748 1588
Facsimile (02) 9748 7244

VIC/TAS

Armstrong World Industries Pty. Ltd.
Unit 1, 88 Henderson Road, Rowville VIC 3178
Telephone (03) 8706 4000
Facsimile (03) 8706 4040

www.armstrongceilings.com.au

Email: scentre@armstrongceilings.com

AWP0118 Printed on Zanders Mega Recycled paper

QLD/NT

Armstrong World Industries Pty. Ltd.
6 Barrinia Street, Slacks Creek QLD 4127
Telephone (07) 3809 5565
Facsimile (07) 3809 5507

SA

Total Building Systems Pty. Ltd.
160 Grand Junction Road, Blair Athol SA 5084
Telephone (08) 7325 7555
Facsimile (08) 7325 7566

WA

Ceiling Manufacturers of Australia Pty. Ltd.
5 Irvine Street, Bayswater WA 6053
Telephone (08) 9271 0777
Facsimile (08) 9272 2801

New Zealand

Forman Building Systems Ltd.
20 Vestey Drive, Mount Wellington, Auckland 1060
Telephone +64 (9) 276 4000
Facsimile +64 (9) 276 414

Inspiring Great Spaces® is a trademark of AFI Licensing LLC. All other trademarks are property of AWI Licensing LLC and/or affiliates.
© 2017 AWI Licensing LLC.

Inspiring Great Spaces®

Armstrong®
CEILING SOLUTIONS