

## **CEILING SYSTEMS**

[ Between us, ideas become reality.™ ]

### **Armstrong Blue Tongue™ Aluminium Grid and Axiom™ Perimeter/Pelmet Systems**

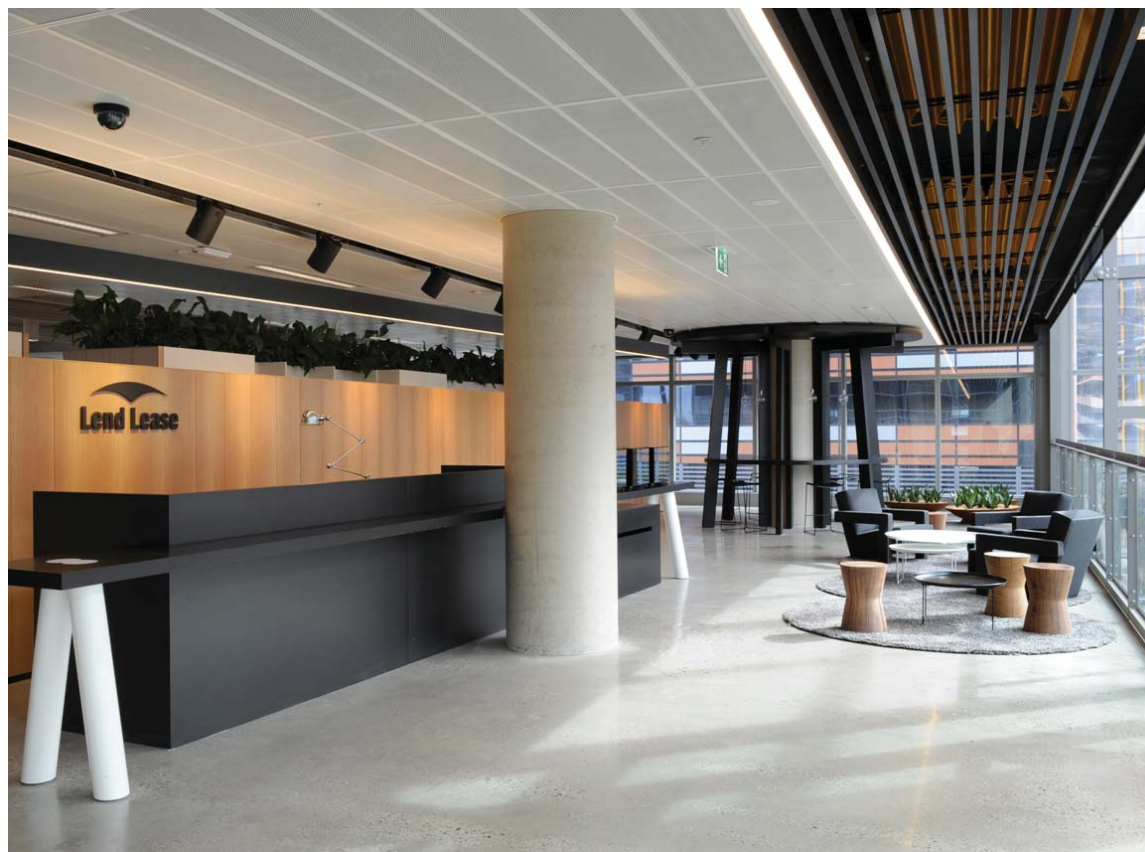

# Armstrong Blue Tongue™ Aluminium Grid and Axiom™ Perimeter/Pelmet Systems

## Armstrong Blue Tongue™ Aluminium Grid Systems

Extruded aluminium grid systems are the natural complement to Armstrong acoustic ceiling panels in A-Grade commercial applications.

Armstrong delivers more than 30 years of expertise in extrusion technologies and aluminium ceiling solutions to the Australian and New Zealand markets.

Armstrong offers a complete range of Modular, One Way and Two Way Accessible Systems, featuring “Blue Tongue” interlocking technology, for both Mineral Fibre and Metal ceiling panels

## Features of the Armstrong “Blue Tongue” Systems

- Full and rapid demountability and re-use of components
- Complete range of interlocking accessories
- Choice of module sizes, including 1200x1200, 1350x1350 and 1500x1500
- Engineered and tested system to support full range of mechanical services
- Full access to plenum
- Complete integration with Axiom Perimeter/Pelmet Systems
- Pre-engineered accessories are available for rapid installation

## Technical Features

- Produced from proven 6063 T5 grade extruded aluminium
- Polyester Powdercoat hardened finish
- Complete integration with Armstrong “Axiom” Perimeter/Pelmet Systems
- Compliant to AS/NZS2785:2000 – Suspended Ceiling Code
- 30 year manufacturers Ceiling System Warranty

## Axiom Perimeter/Pelmet Solutions

To complete the ceiling Armstrong provides a comprehensive range of perimeter solutions, including: wall angles, margin trims and even our proprietary Axiom™ composite pelmet and slotted air handing systems.

## Custom Ceiling Solutions

In addition to a wide range of standard systems, the Armstrong Technical Services Group has the capacity of developing custom solutions to suit most commercial ceiling requirements.



Clean mitred cross runner intersection.

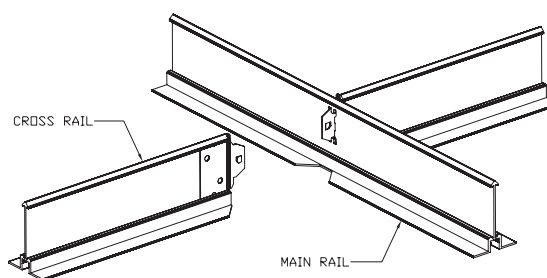

Armstrong “Blue Tongue” positive lock connection.

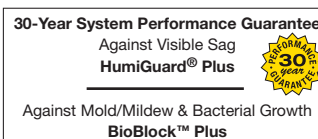

# One Way Ceiling Systems

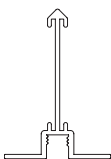
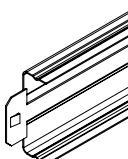
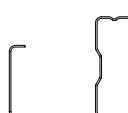
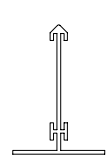
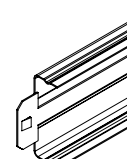
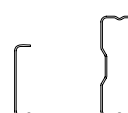

## One Way System for Mineral Fibre Panel - Component Specification

Module	Detail	Top Hat Main Bar	Locking "C" Splines	"C" Splines	Detail	Flat Face Main Bar	Locking "C" Splines	"C" Splines
								
<b>1200mm</b>	<b>Item:</b>	ALOWETHMR	ALSPLINE4	ALSPLINE1C	<b>Item:</b>	ALOWEFFMR	ALSPLINE4B	ALSPLINE1B
	<b>Height</b>	45	35	25	<b>Height</b>	45	35	25
	<b>Face Width</b>	32	11.5	10	<b>Face Width</b>	32	11.5	10
	<b>Length</b>	3600	1200	1187	<b>Length</b>	3600	1200	1187
	<b>Routs</b>	400cc.			<b>Routs</b>	400cc.		
<b>1350mm</b>	<b>Item:</b>	ALOWETHMR	ALSPINE 5	ALSPLINE 2C	<b>Item:</b>	ALOWEFFMR	ALSPLINE5B	ALSPLINE2B
	<b>Height:</b>	45	35	25	<b>Height</b>	45	35	25
	<b>Face Width</b>	32	11.5	10	<b>Face Width</b>	32	11.5	10
	<b>Length:</b>	3600	1350	1345	<b>Length:</b>	3600	1350	1345
	<b>Routs:</b>	450cc.			<b>Routs</b>	450cc.		
<b>1500mm</b>	<b>Item:</b>	ALOWETHMRH	AISPLINE 6	ALSPLINE 5A				
	<b>Height:</b>	50	35	35				
	<b>Face Width</b>	32	11.5	11.5				
	<b>Length:</b>	4500	1500	1487				
	<b>Routs:</b>	500cc						

**Note:** Details on Axiom Perimeters, Wall Angles and Accessories - refer page 9

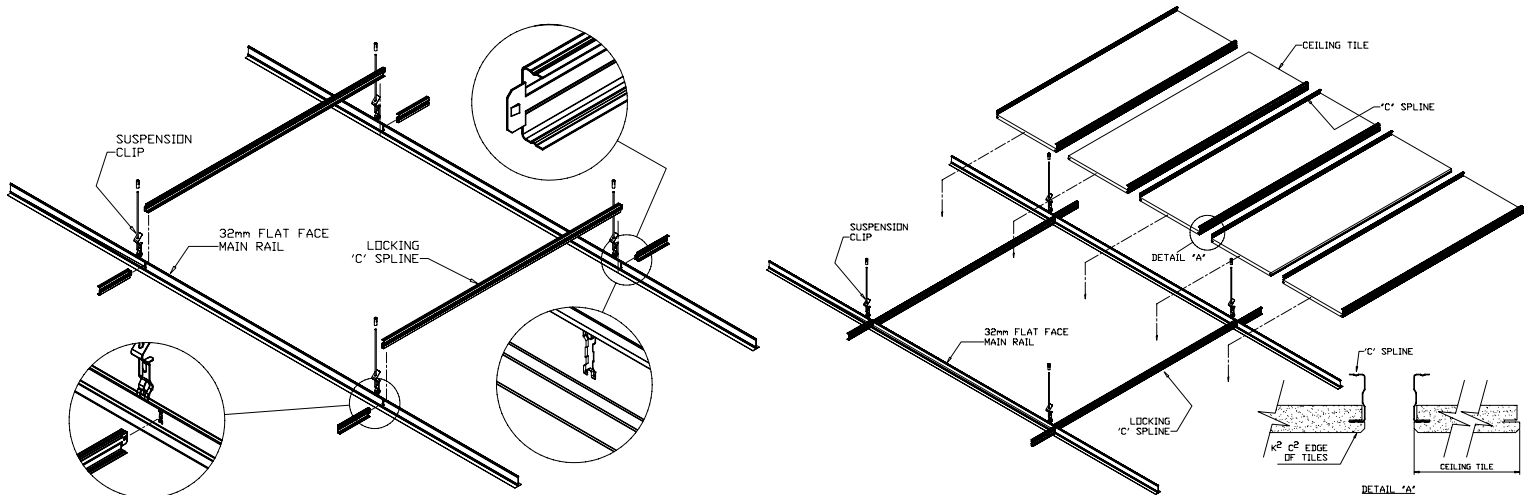

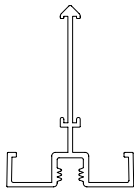
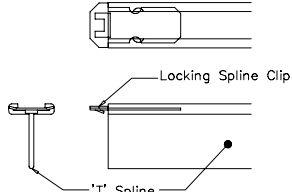

### One Way System for Metal Panel - Component Specification

Detail	Top Hat Main bar	Locking Spline
		
<b>Item:</b>	ALOWHTHMR	ALSPLINEOWH
<b>Height (mm)</b>	50	21
<b>Width (mm)</b>	35	15
<b>Length (mm)</b>	3600	1200*

\* Note: Locking splines available for other modules including 1350 and 1500mm

**Note:** Details on Axiom Perimeters, Wall Angles and Accessories – refer page 9

### Key Features for Armstrong One Way Systems

- Up-market visual of One Way System
- Full Accessibility of plenum
- Simple removal of panels
- Robust and high tolerance system, without creep or racking
- Cleanest visual, with minimum exposed grid
- Custom sizes available

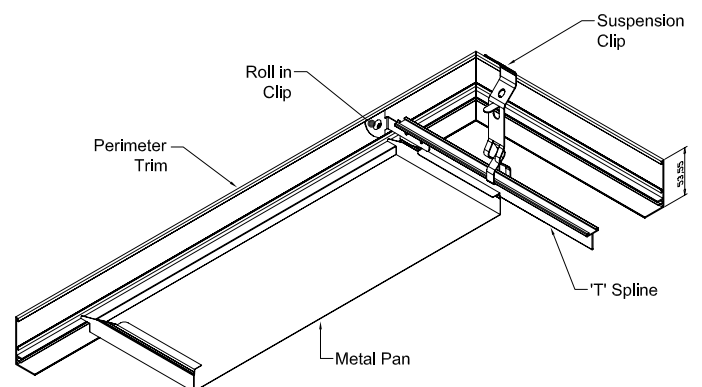
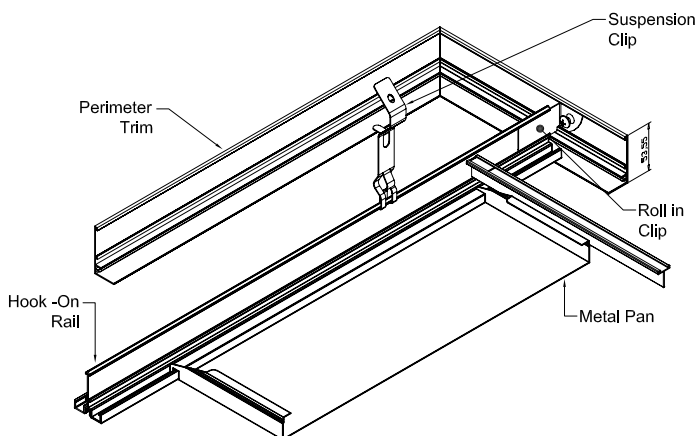

Additional information and detailed drawings on the Armstrong Blue Tongue One Way Accessible System can be found at [www.armstrongceilings.com.au](http://www.armstrongceilings.com.au)

# Axiom Perimeters / Wall Angles and Accessories

## Perimeter / Transition Trims

<b>Item:</b>	ALPT4500LL	ALPTQLFF45	ALPTFF	ALPT3600PB	ALPTBHT	ALMRTH3600OS	ALMRTH4050OS	ALMRTH4500OS
<b>Description</b>	Top Hat with 70mm Upturn	Flat Face	Flat Face with Horizontal Leg for 13 PB	Top Hat with Horizontal Leg for 13 PB	Bulk Head Trim	Top Hat Punched one side @ 1200cc.	Top Hat Punched one side @ 1350cc.	Top Hat Punched one side @ 1500cc.
<b>Height (mm)</b>	70	45	45	45	38	45	45	50
<b>Length (mm)</b>	4500	3600	3600	3600	3600	3600	4050	4500
<b>Width: (mm)</b>	41	24	32	32	28	32	32	32

## Perimeter Trims / Accessories for One Way MetalWorks Hook On System

<b>Item:</b>	ALPTONEWAY	ARM-036	ARM-035	ARM-034	ARM-033
<b>Description / Application</b>	Perimeter Trim	Perimeter Trim Joiner Grub screw fastening	Main Runner Joiner	Roll In Clip Connects Main Runner to Perimeter Trim	Roll In Clip Connects Locking Spline to Perimeter Trim
<b>Dimensions</b>	51(h) x 25 (w) x 3600mm				

## Perimeter Trims: Wall Angles

<b>Item:</b>	AL009RICP	AL009RICD	AL008RIC
<b>Description</b>	Shadow line Suits roll in clip	Lipped Shadowline Suits roll in clip	Std "L" Suits roll in clip
<b>Height (mm)</b>	29	30	20
<b>Width (mm)</b>	29	29	20
<b>Length (mm)</b>	3600mm	3600mm	3600mm

## Accessories

<b>Item No.</b>	ALRICS	ALMRJL	ALMRJL90	ALMRJGS	ALRICL	ALLP	GSD	ALSCL
<b>Description</b>	Roll In Clip Small	Main Bar Joiner.	90 Degree Bracket	Grub screw Main Bar Joiner	Roll in Clip Large	Locking Plate For Roll In Clip (ALRICL)	Grub screw - driver	Suspension Clips
<b>Application of Accessory Item</b>	Connects all sections with all wall angles and Perimeter Trims / Pelmet	Connects all Main beams: 45 and 50mm sections	Used with all Main beams 45 and 50mm sections	Connects all Main beams: 45 and 50mm sections	For connecting Main or Cross Runners to Perimeter Trims	Eliminates mechanical fastening	For use with Grub screw Main Bar Joiner and Roll in Clip Large	For use on all Main Beam and Perimeter Trims and Axiom Pelmet

# CEILING SYSTEMS

[ Between us, ideas become reality.™ ]

## Armstrong, the Global Leader in Acoustic Ceilings

### NSW

Armstrong World Industries Pty. Ltd.  
99 Derby Street,  
Silverwater NSW 2128  
Telephone (02) 9748 1588  
Facsimile (02) 9748 8449

### VIC/TAS

Armstrong World Industries Pty. Ltd.  
29-39 Mills Road,  
Braeside VIC 3195  
Telephone (03) 9580 9633  
Facsimile (03) 9587 5139

### QLD/NT

Armstrong World Industries Pty. Ltd.  
6 Barrinia Street,  
Slacks Creek QLD 4127  
Telephone (07) 3809 5565  
Facsimile (07) 3809 5507

### SA

Up-Side Building Systems  
376 Cormack Road,  
Wingfield SA 5013  
Telephone 1300UPSIDE  
Facsimile (08) 8349 5956

### WA

Ceiling Manufacturers of Australia Pty. Ltd.  
5 Irvine Street,  
Bayswater WA 6053  
Telephone (08) 9271 0777  
Facsimile (08) 9272 2801

### New Zealand

Forman Building Systems Ltd.  
PO Box 12349,  
Penrose, Auckland  
Telephone 64-9-276 4000  
Facsimile 64-9-276 4141

[www.armstrongceilings.com.au](http://www.armstrongceilings.com.au)

