

METRO SERIES
F500MS HINGED DOOR, OPEN OUT

CROSS SECTION

Date 01.11.09 Scale 1:2

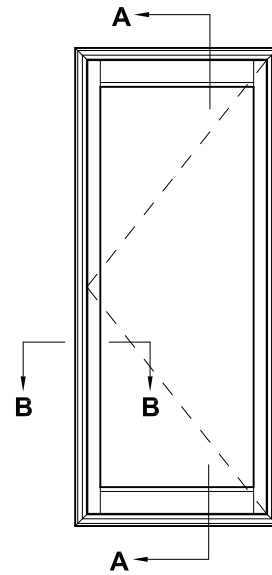
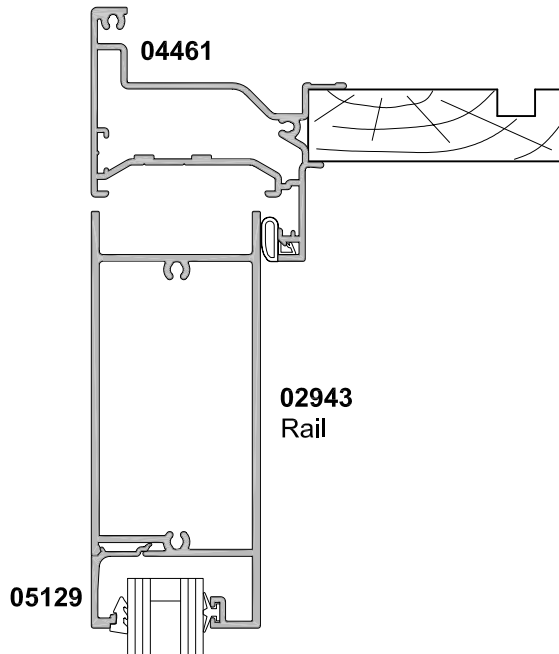

SECTION A-A

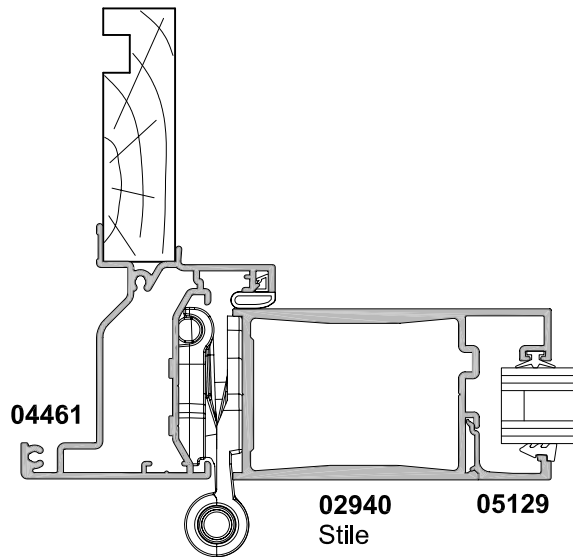
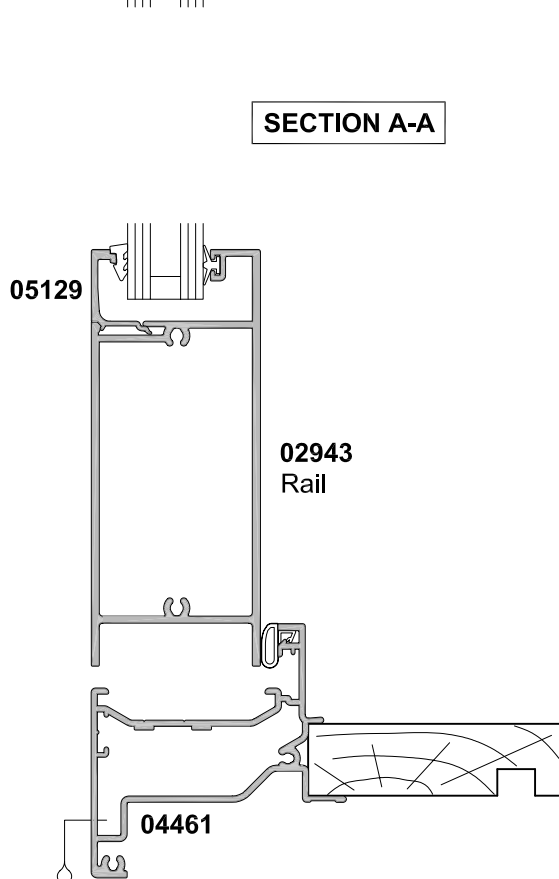

SECTION B-B

METRO SERIES
F520MS HINGED DOOR, OPEN IN
CROSS SECTION

Date 01.11.09 Scale 1:2

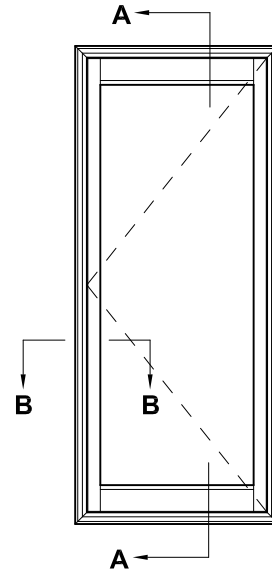
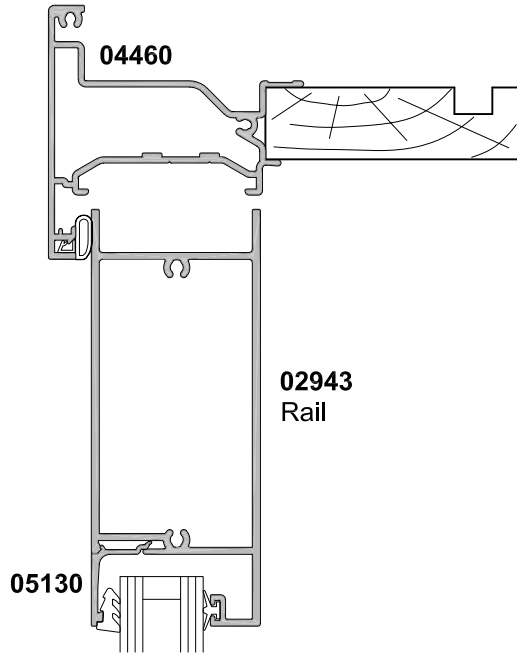

SECTION A-A

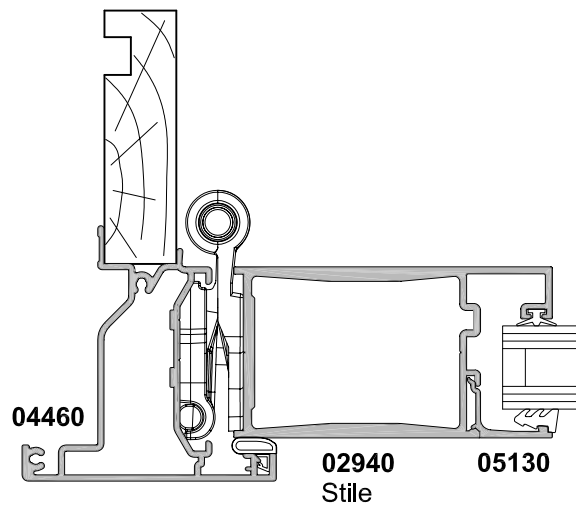
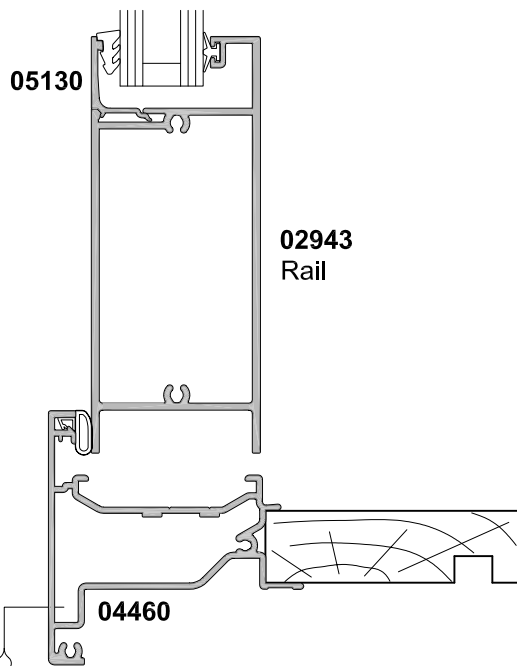

SECTION B-B

CROSS SECTION

Date 01.11.09 Scale 1:2

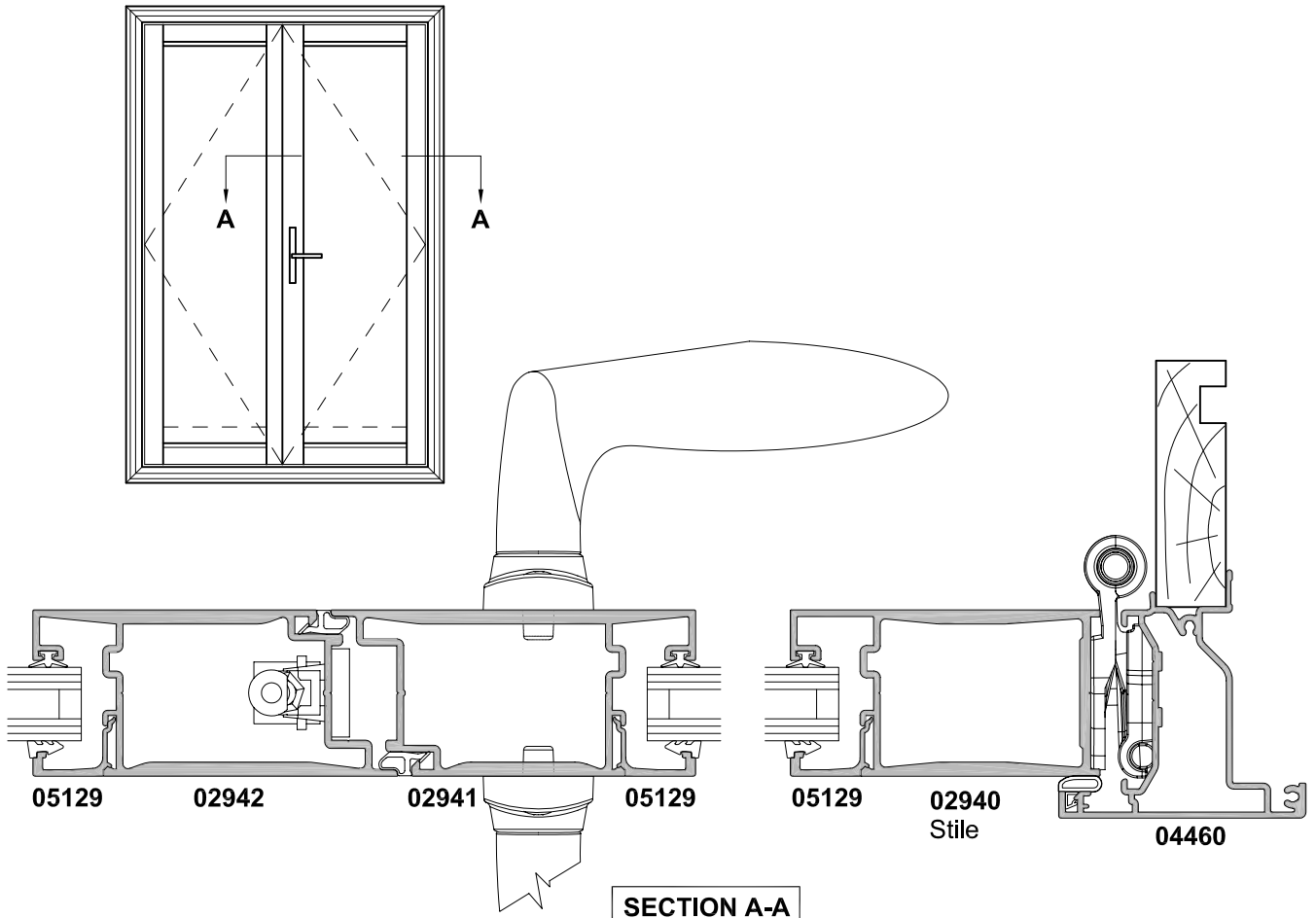

SECTION A-A

OPEN IN FRENCH DOOR

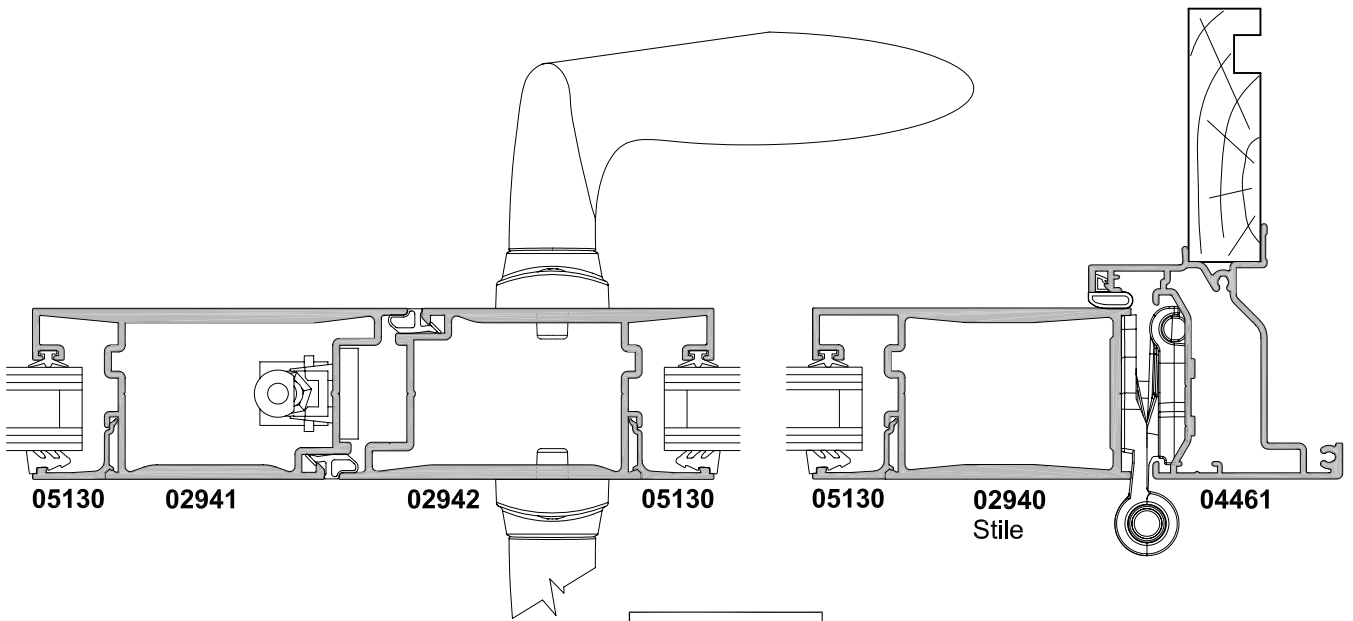

SECTION A-A

OPEN OUT FRENCH DOOR

METRO SERIES
F520MS OPEN IN & F500MS OPEN OUT
HINGED DOOR COUPLED SIDELIGHT

CROSS SECTION

Date 01.06.11 Scale 1:2

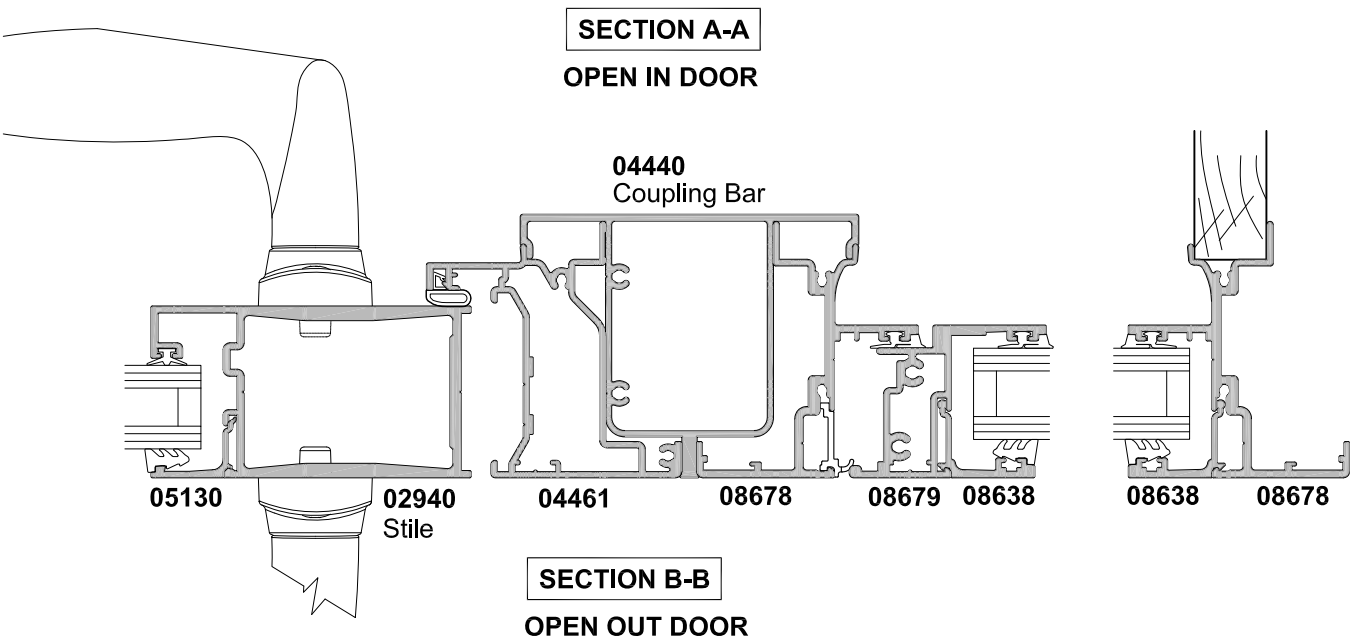
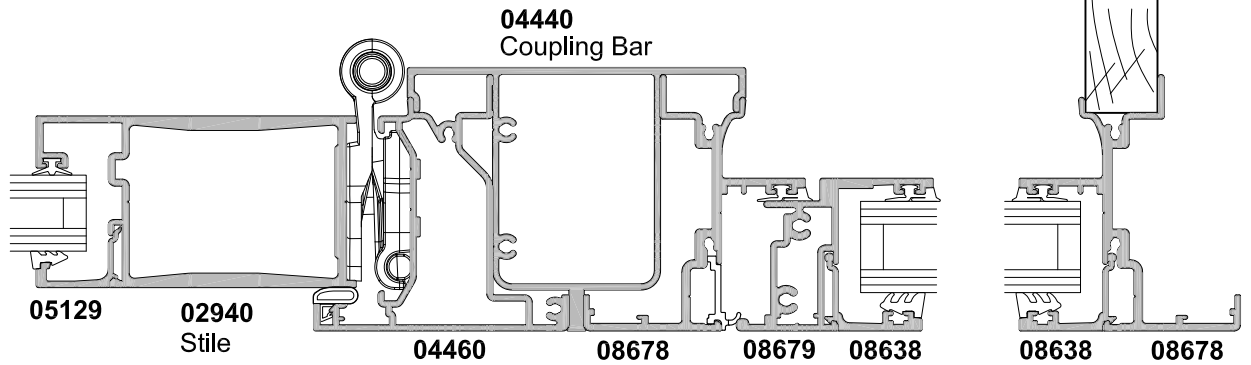
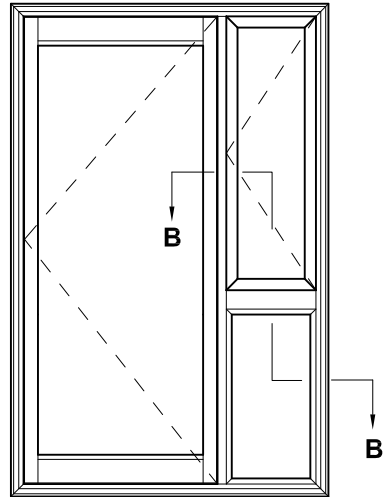
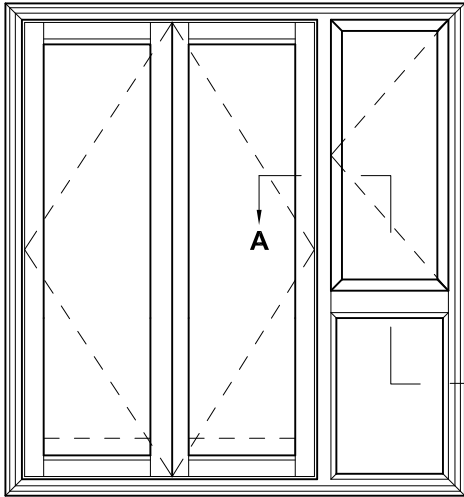

METRO SERIES
F520MS OPEN IN & F500MS OPEN OUT
HINGED DOOR COUPLED OVERLIGHT

CROSS SECTION

Date 01.06.11 Scale 1:2

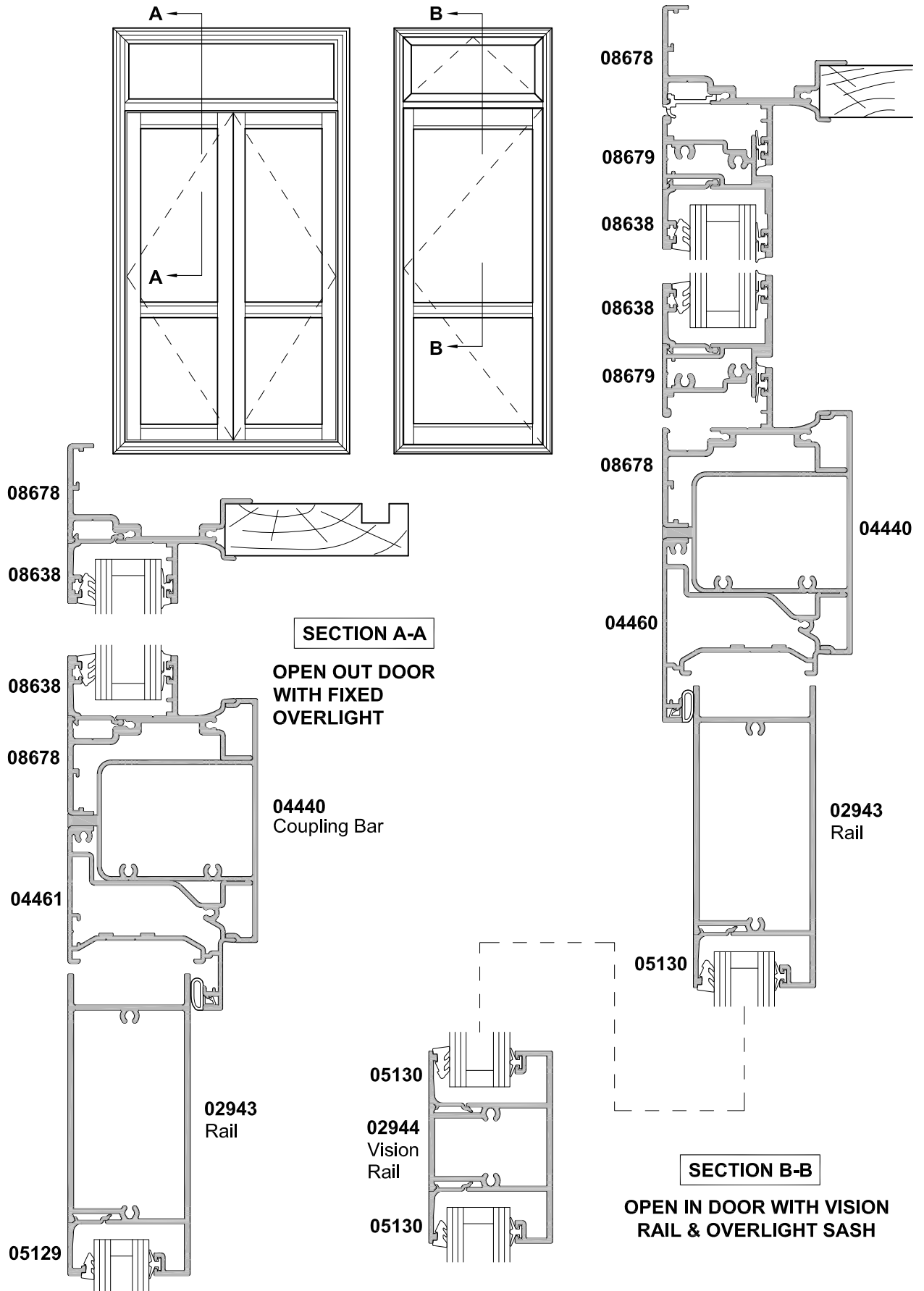

**METRO SERIES
HINGED DOOR
COUPLING OPTIONS**

CROSS SECTION

Date 01.06.11 Scale 1:2

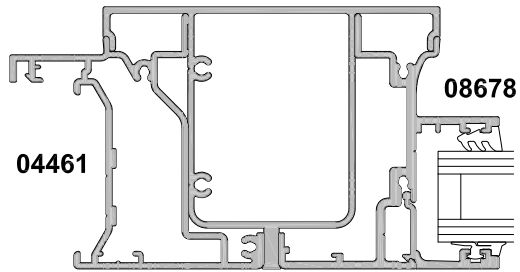

04440
180° COUPLING BAR

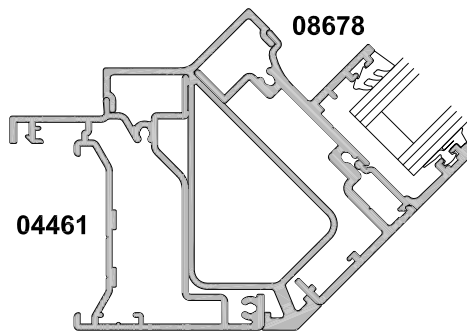

04443
135° COUPLING BAR

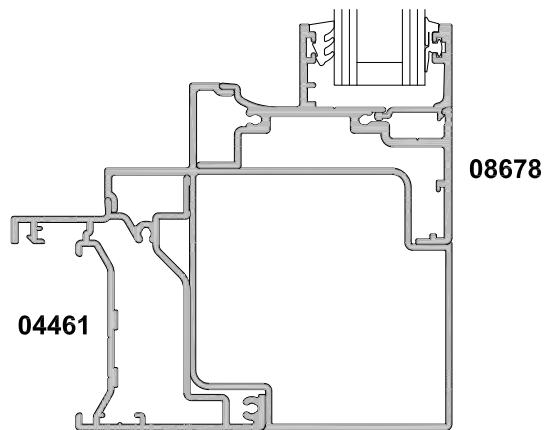

04444
90° COUPLING BAR

METRO SERIES
F520MS OPEN IN & F500MS OPEN OUT
MULLION SIDELIGHT

CROSS SECTION

Date 01.11.09 Scale 1:2

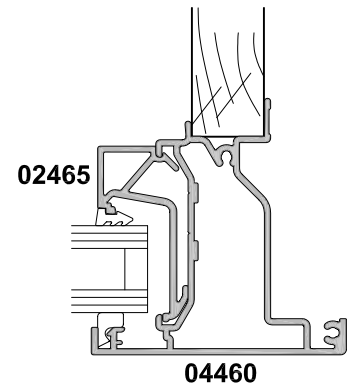
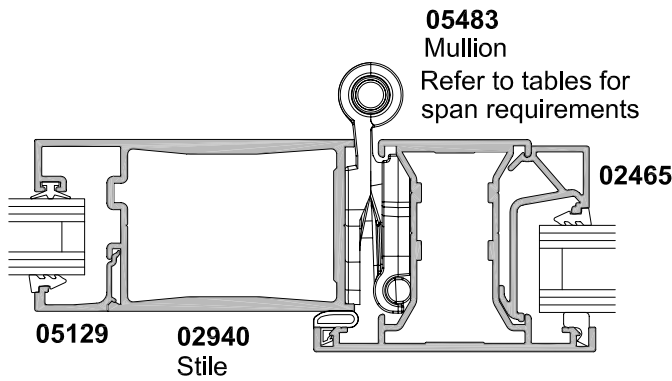
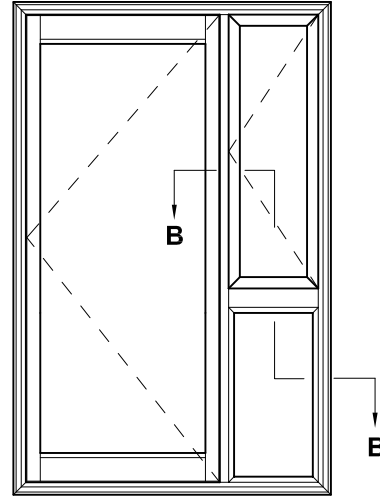
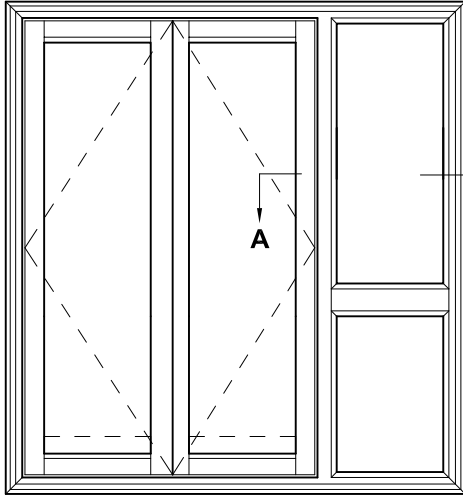

SECTION A-A

OPEN IN DOOR

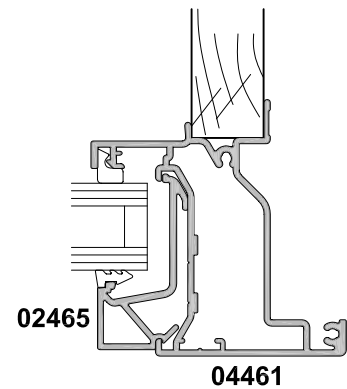
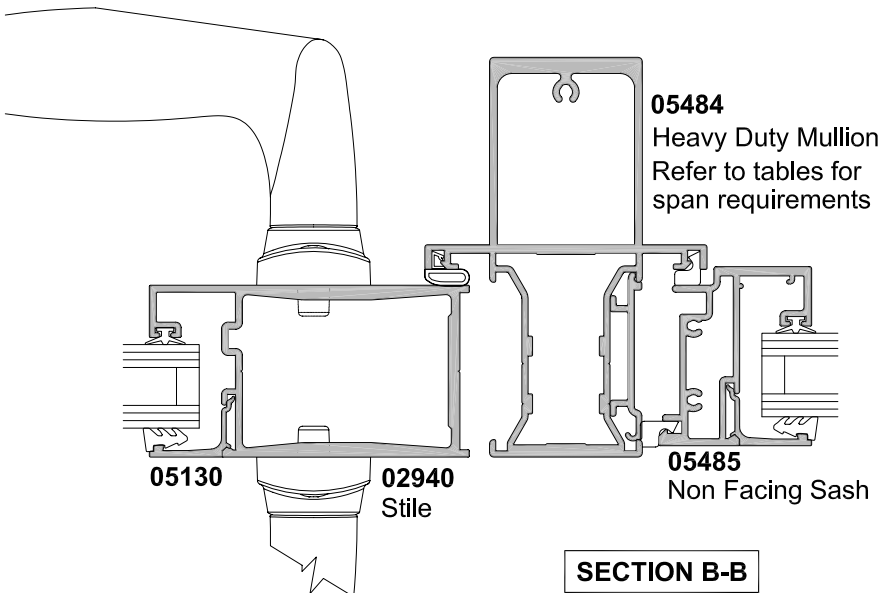

SECTION B-B

OPEN OUT DOOR

METRO SERIES
F520MS OPEN IN & F500MS OPEN OUT
HINGED DOOR TRANSOM OVERLIGHT

CROSS SECTION

Date 01.11.09 Scale 1:2

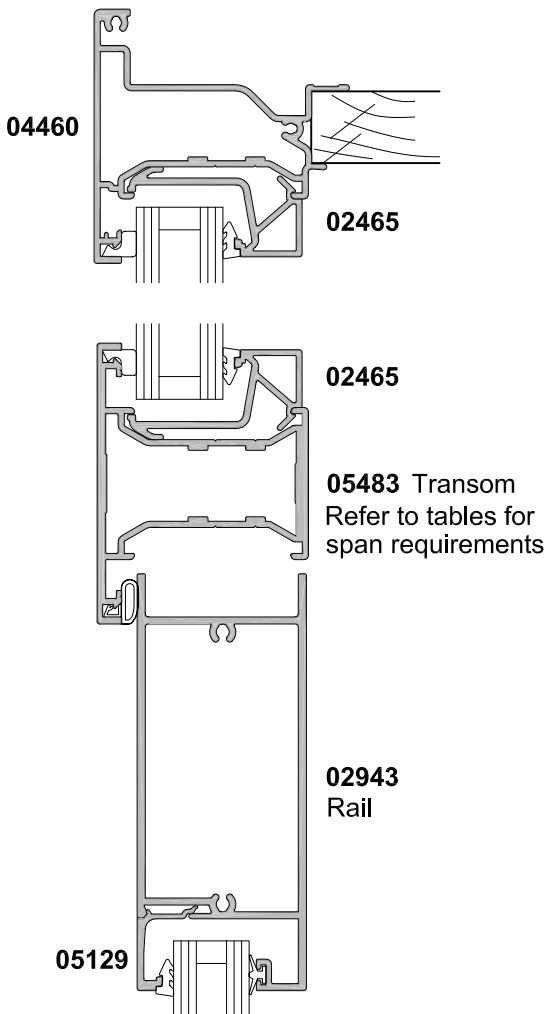
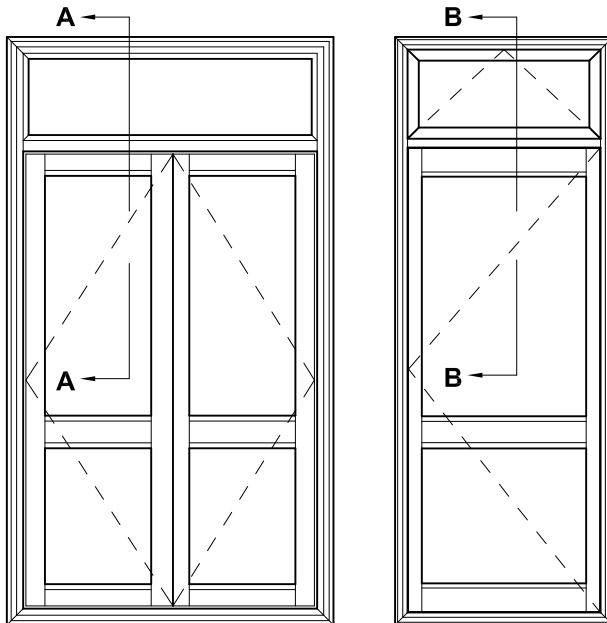

SECTION A-A

DOUBLE GLAZED OPEN IN DOOR

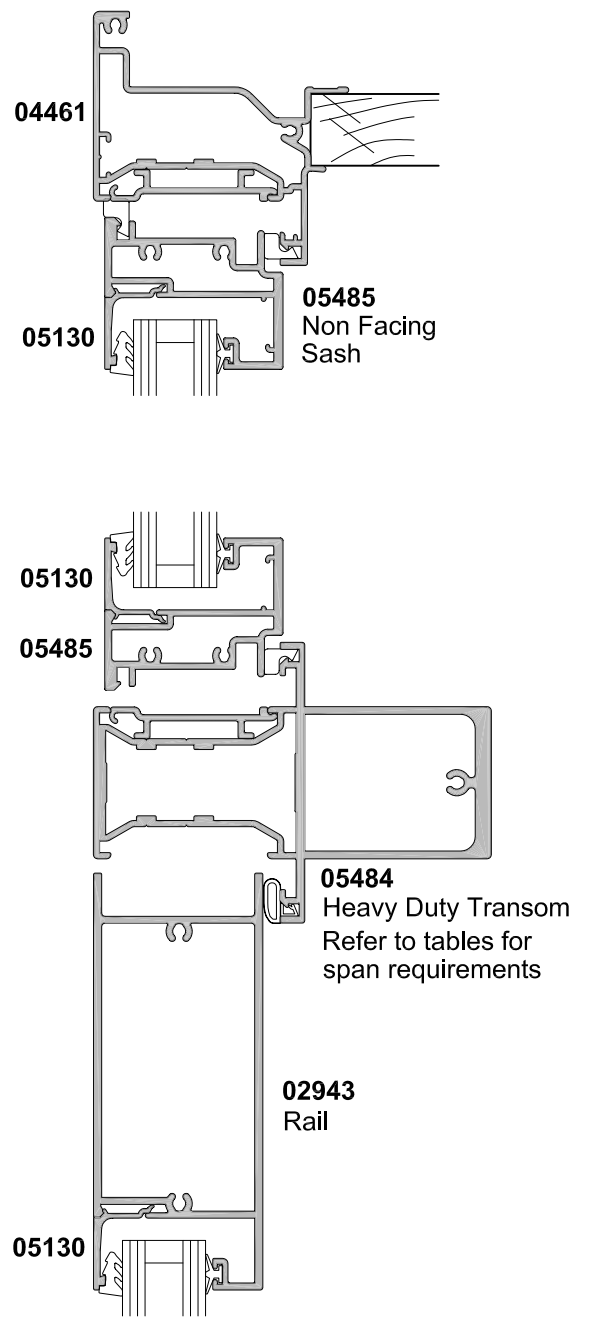

SECTION B-B

DOUBLE GLAZED OPEN OUT DOOR

METRO SERIES
PIVOT DOOR MAGNUM PANEL
CROSS SECTION

Date 01.11.19 Scale 1:2

PIVOT DOORS ARE ONLY SUITABLE FOR SHELTERED LOCATIONS

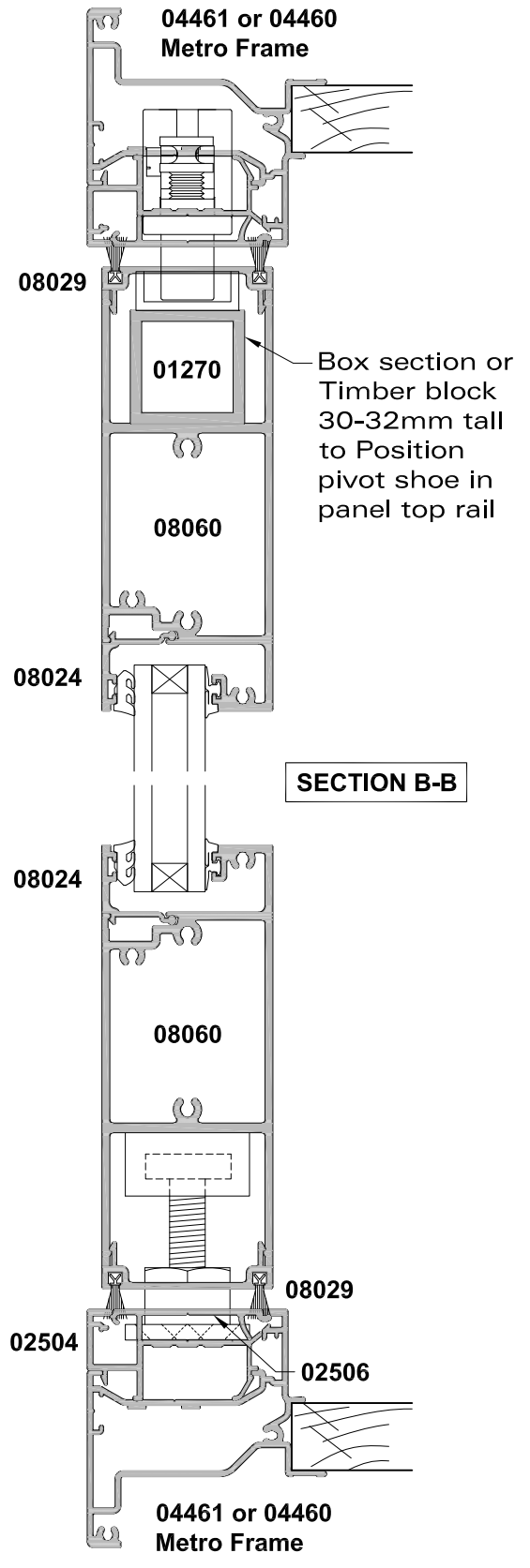
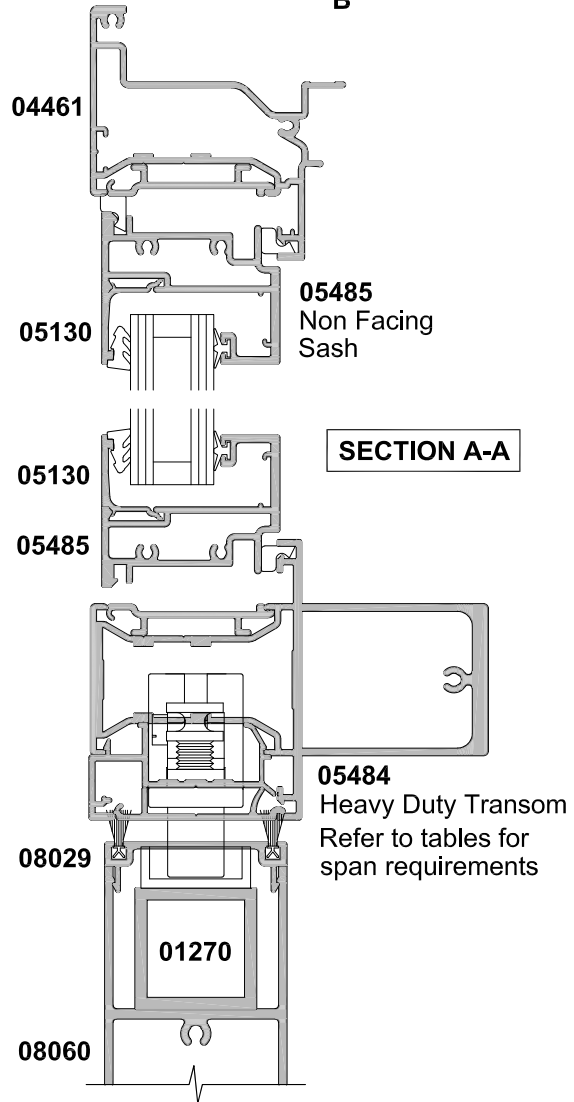
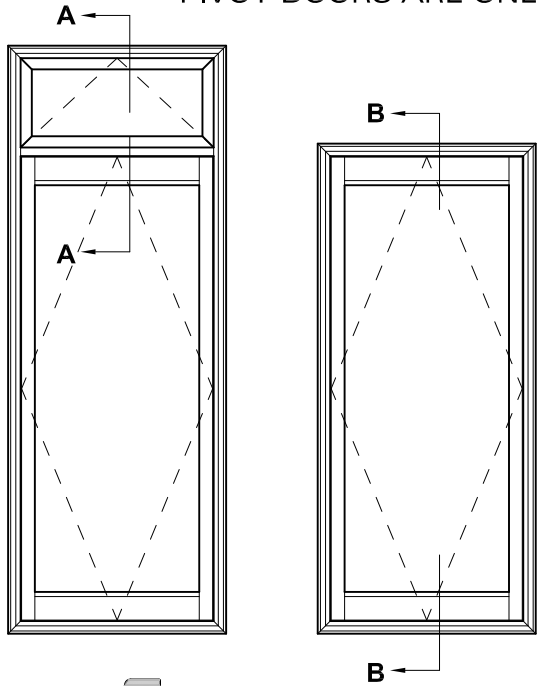

**METRO SERIES
PIVOT DOOR MAGNUM PANEL**

CROSS SECTION

Date 01.11.19 Scale 1:2

PIVOT DOORS ARE ONLY SUITABLE FOR SHELTERED LOCATIONS

