

Details on this page are indicative only. Responsibility for flashing design and cladding junctions remain with the designer of the building. Support angles and built out framing will need to be engineered to suit the application.

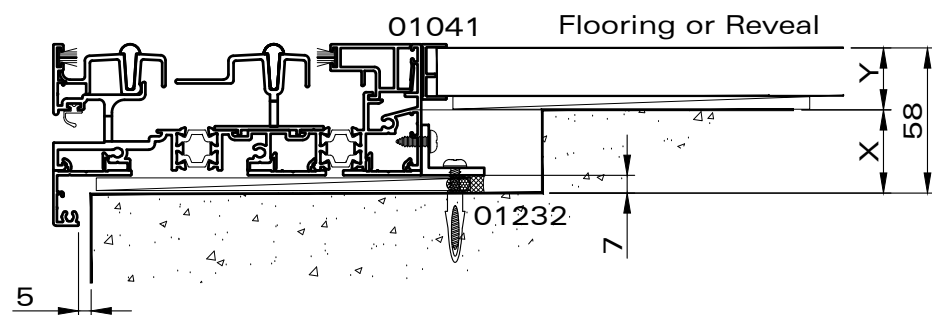
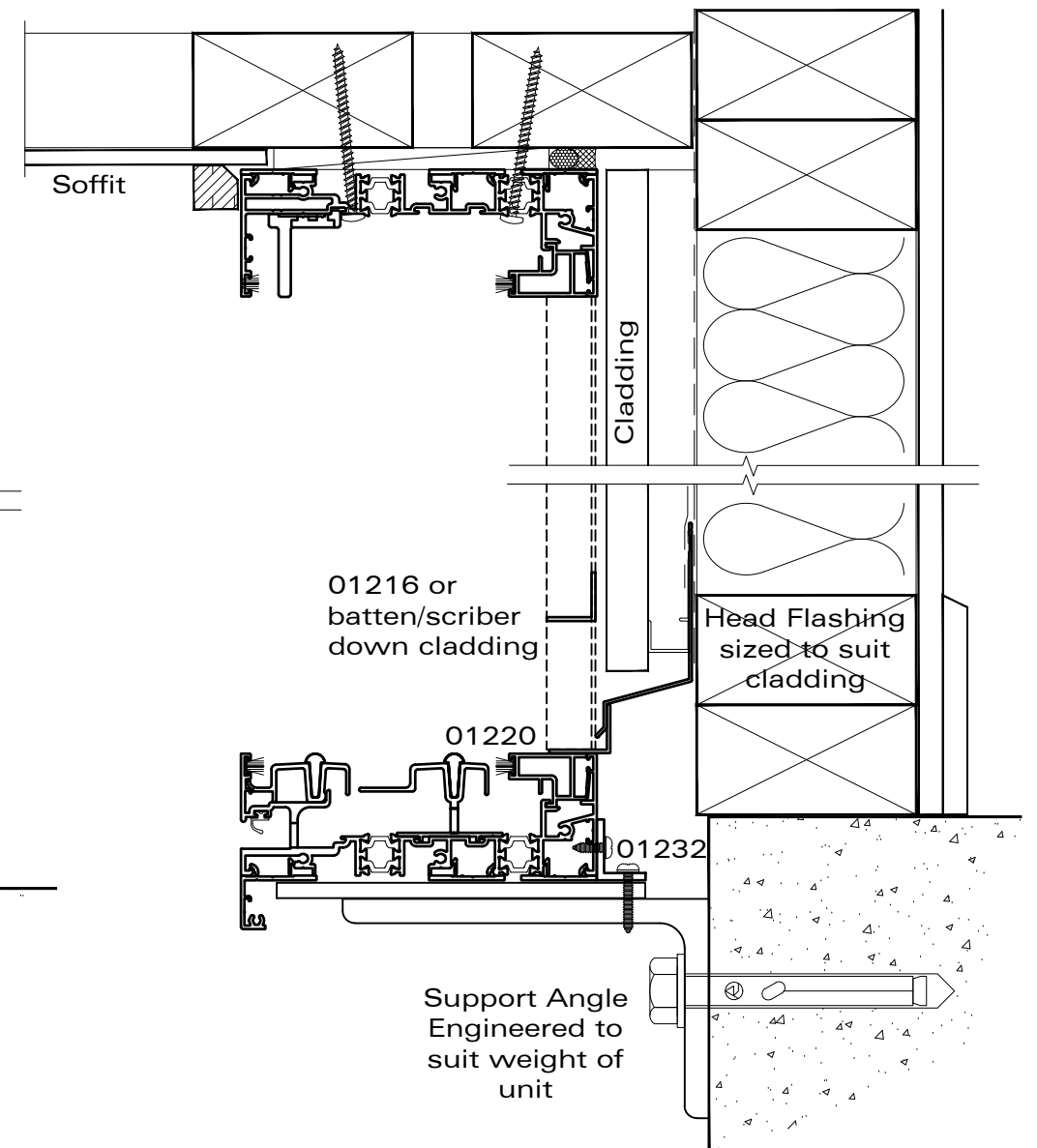
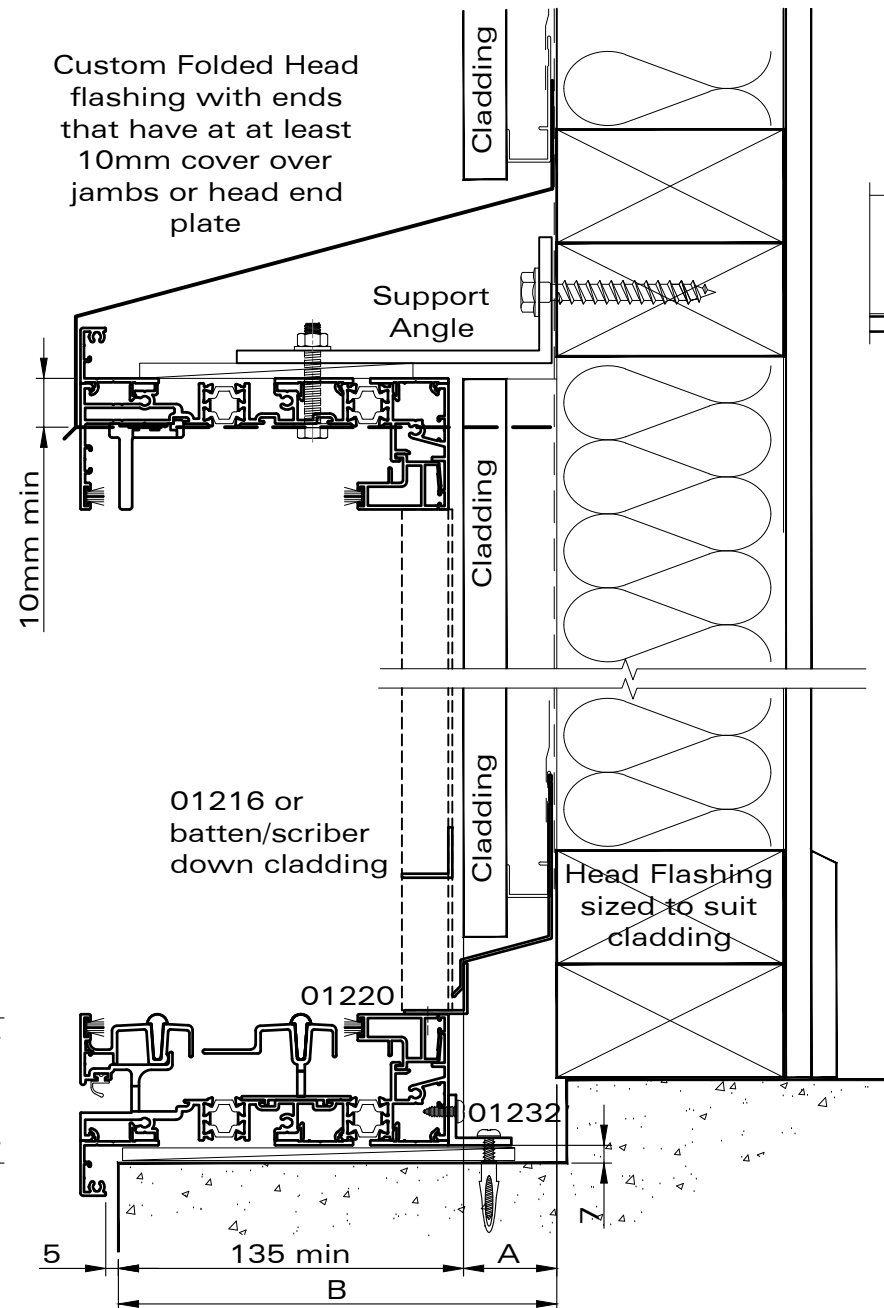
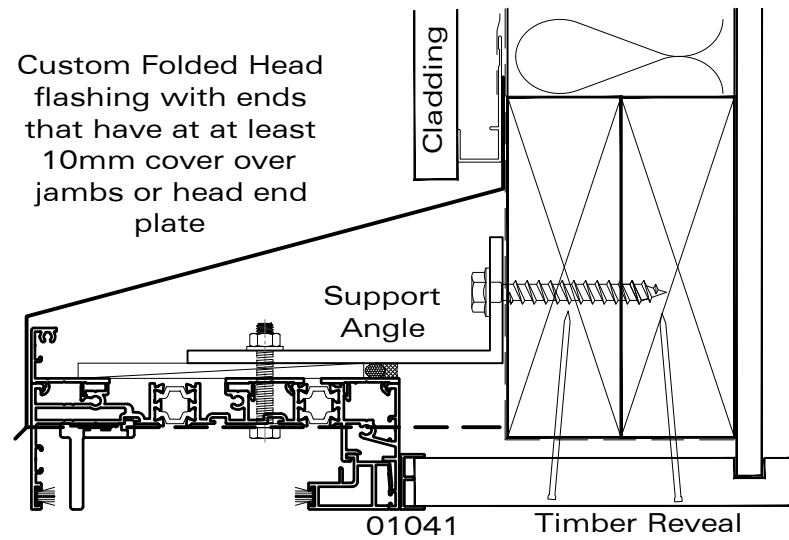
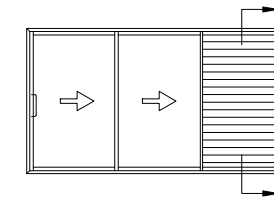
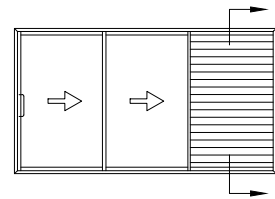

Rebate Height (X) = 58 - (Y) Flooring Thickness

Rebate Depth (B) = 135 + (A) Cladding Thickness

Alternative Sill and Head Support Options



Details on this page are indicative only. Responsibility for flashing design and cladding junctions remain with the designer of the building. Support angles and built out framing will need to be engineered to suit the application.

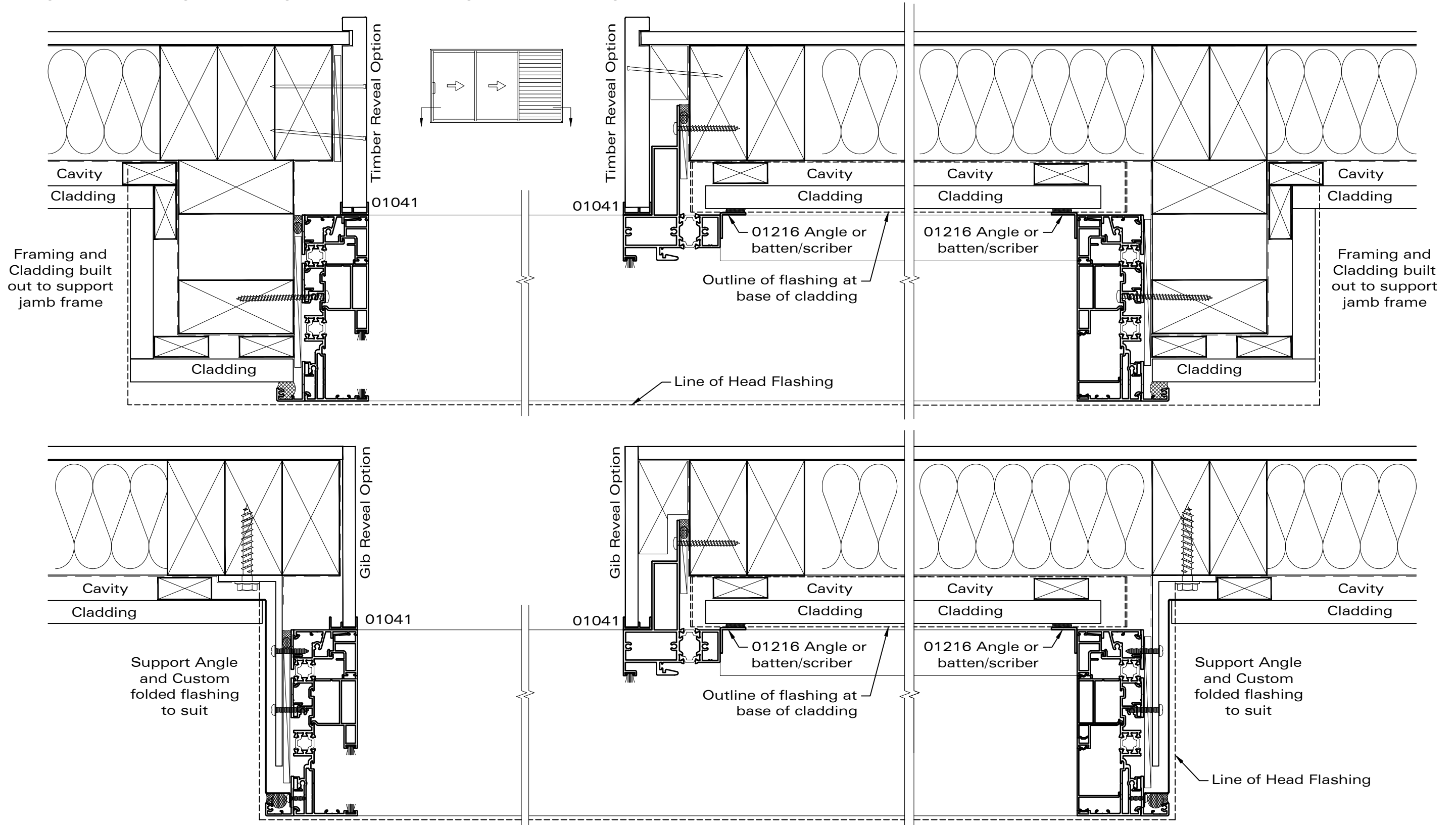

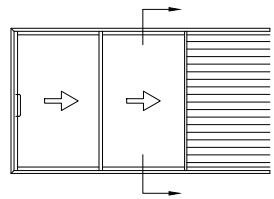

Details on this page are indicative only. Responsibility for flashing design and cladding junctions remain with the designer of the building. Support angles and built out framing will need to be engineered to suit the application.

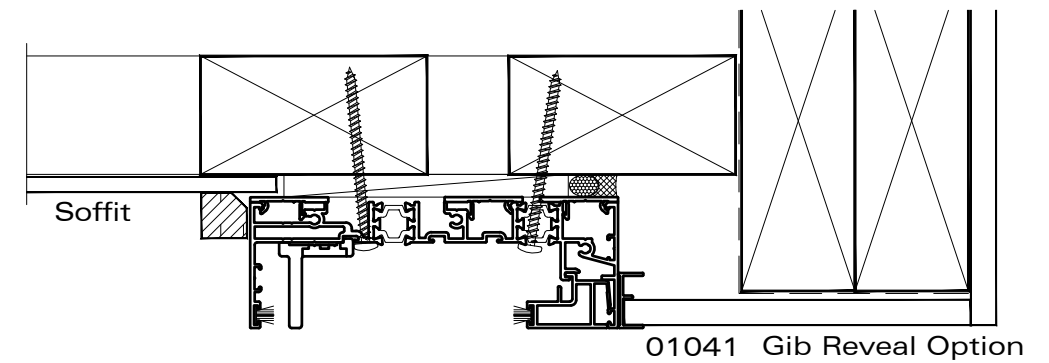
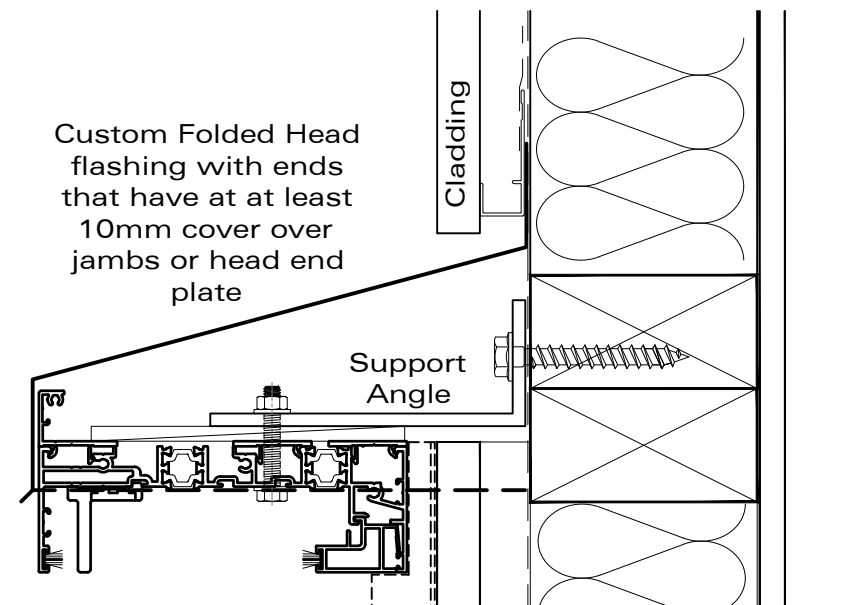
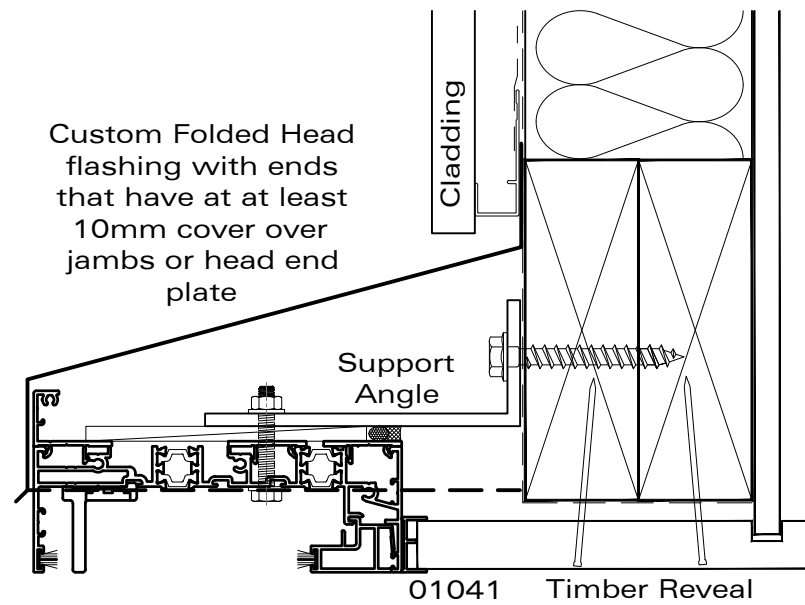
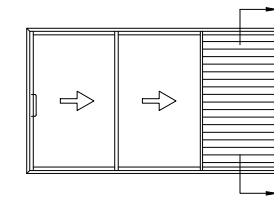
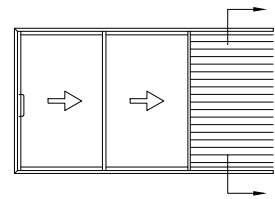

Alternative Interior finishing and Sill/Head Support Options

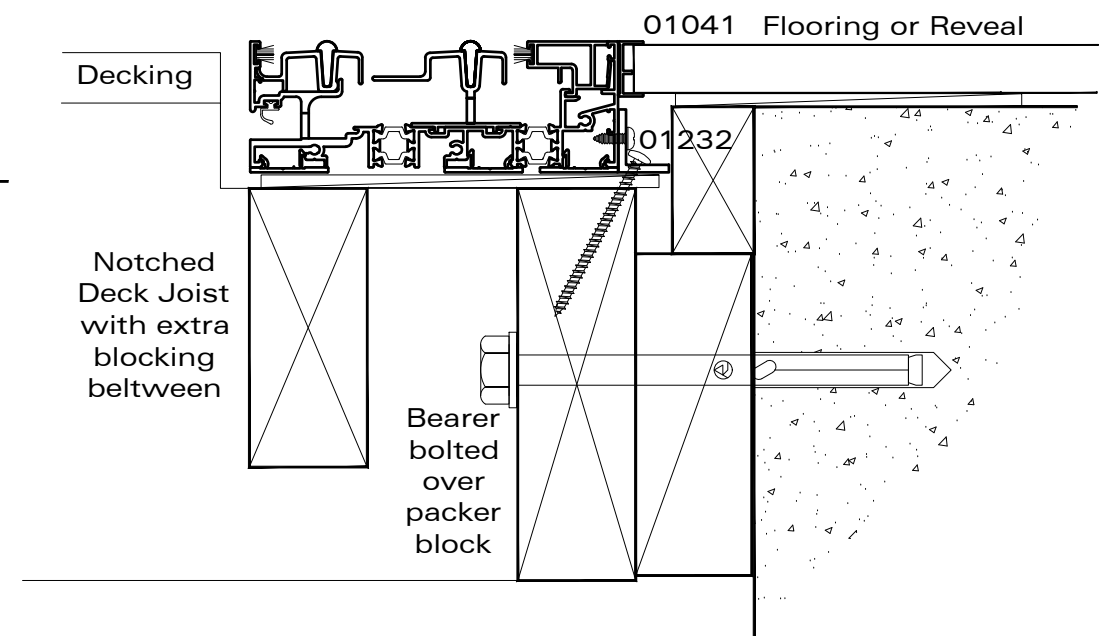
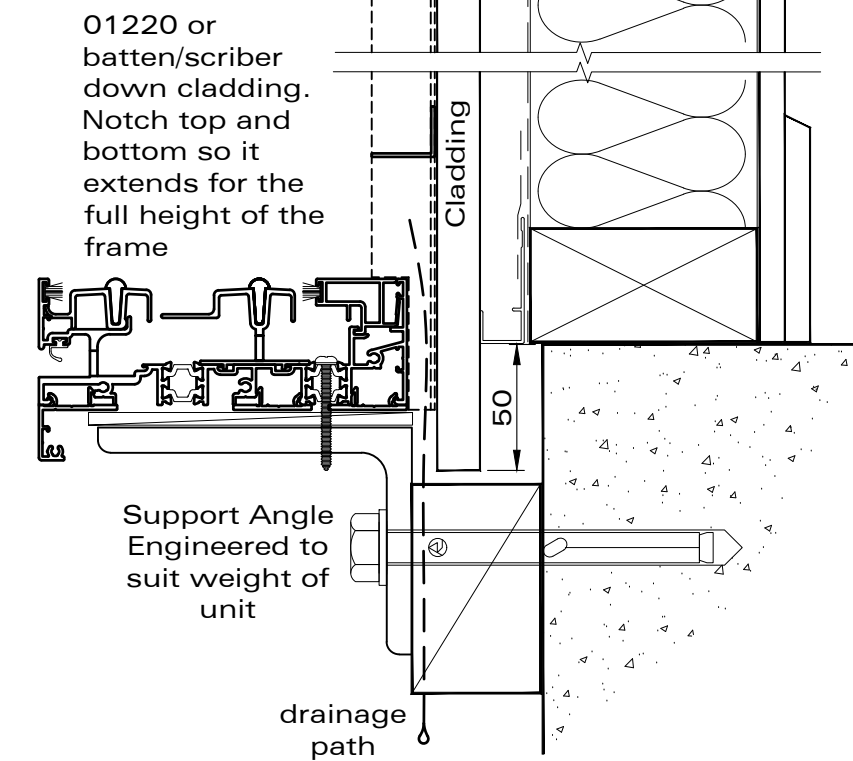
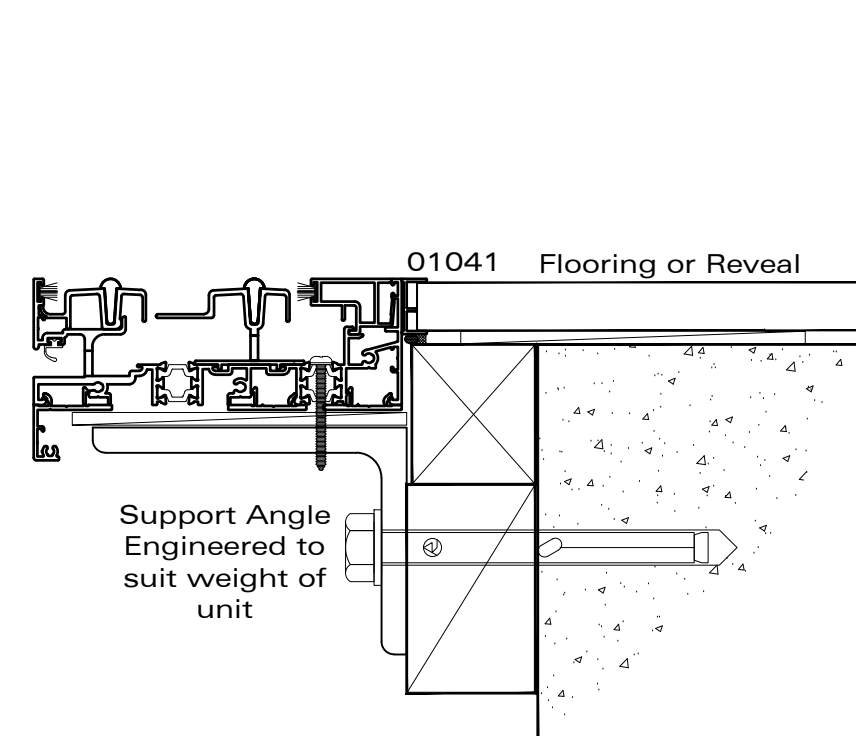



Details on this page are indicative only. Responsibility for flashing design and cladding junctions remain with the designer of the building. Support angles and built out framing will need to be engineered to suit the application.

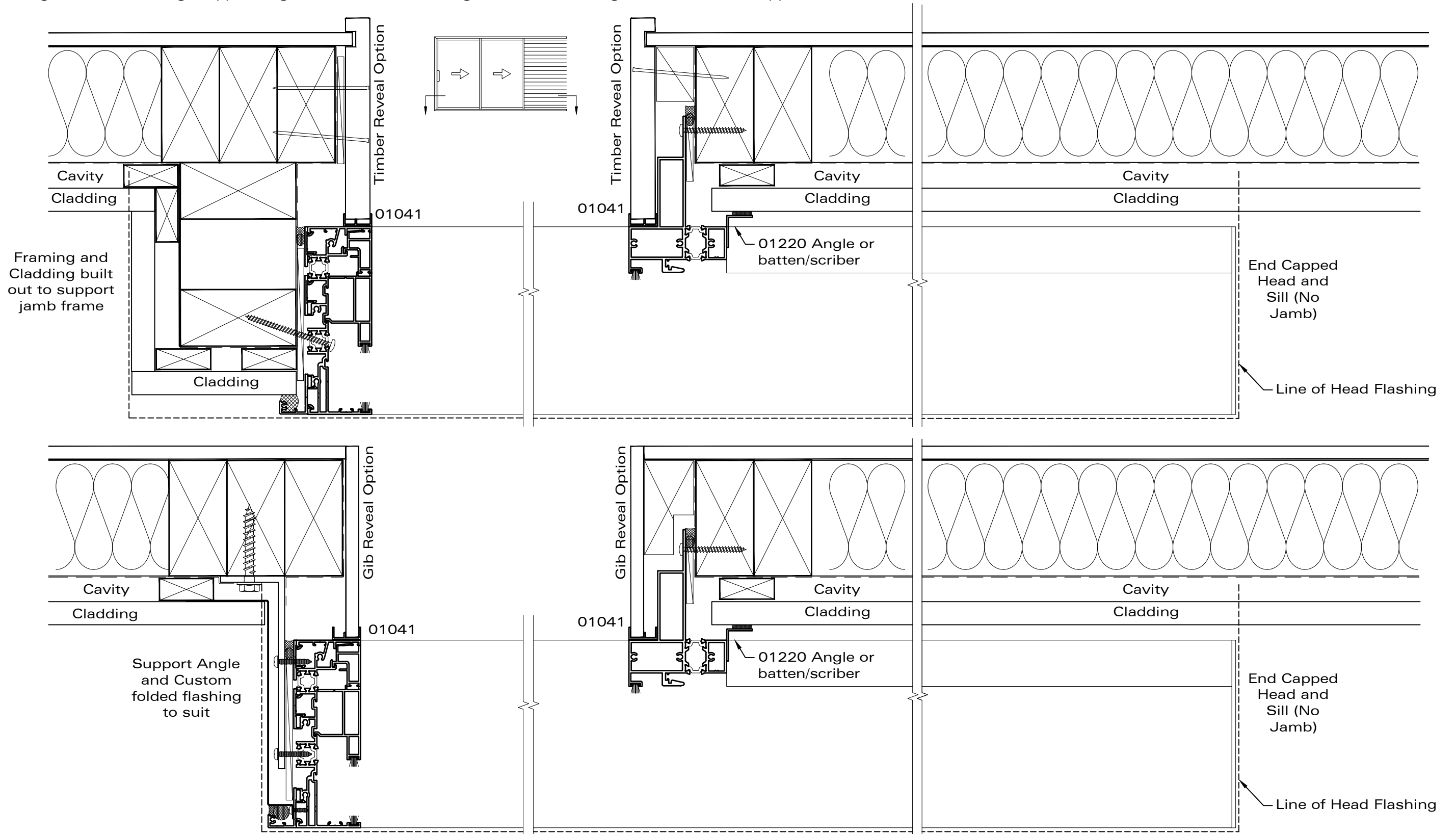

NB. Technical specification subject to change without notice.

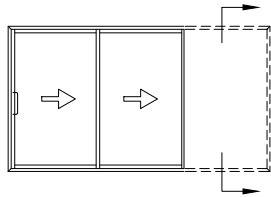

Details on this page are indicative only. Responsibility for flashing design and cladding junctions remain with the designer of the building.  
it is optional whether a jamb frame is used inside the cavity. Refer to over wall Sectionals for ideas on detailing the frame outside of the cavity.

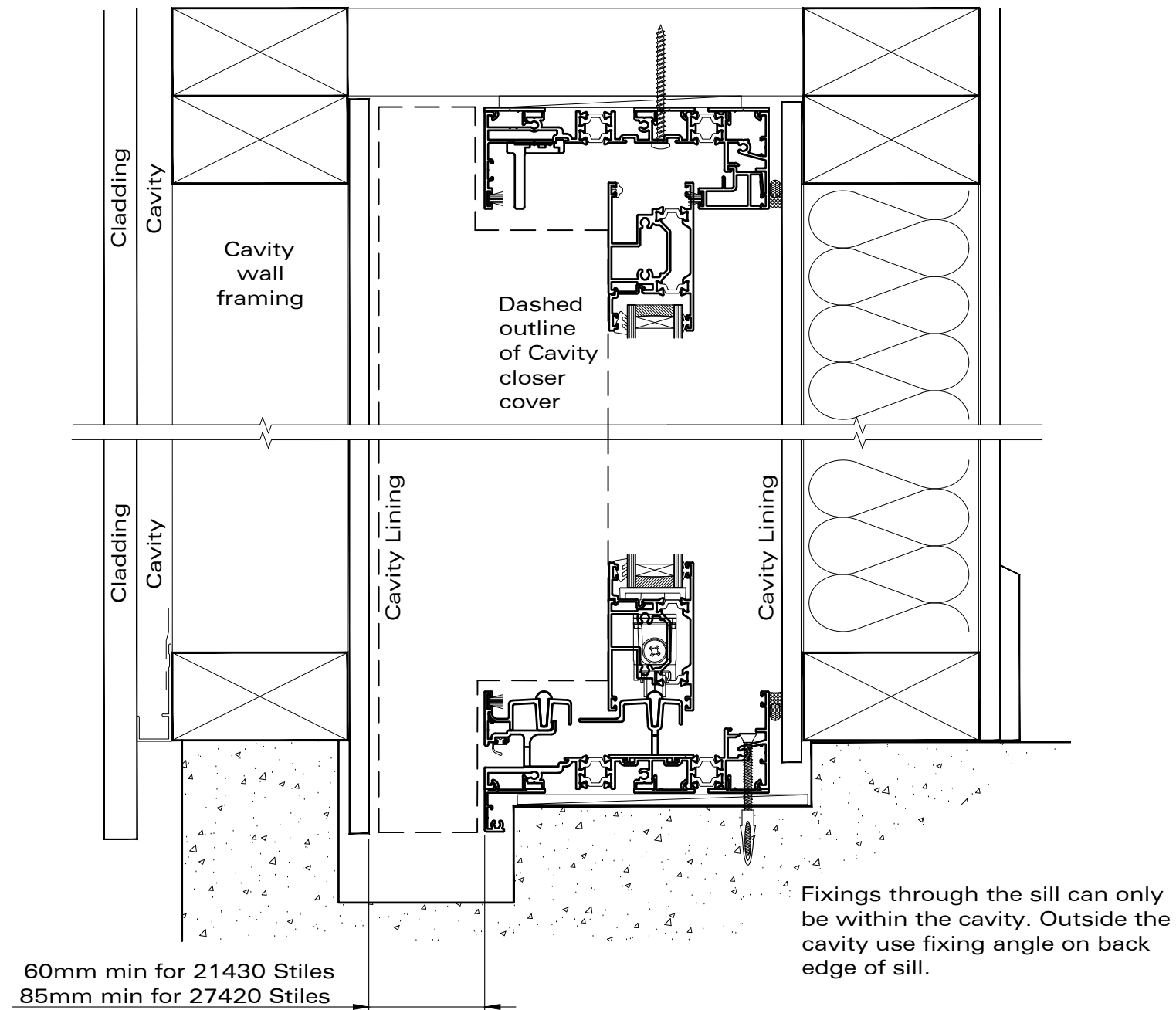

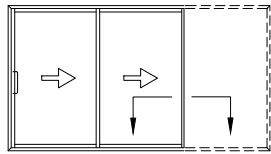

Details on this page are indicative only. Responsibility for flashing design and cladding junctions remain with the designer of the building.  
it is optional whether a jamb frame is used inside the cavity. Refer to over wall Sectionals for ideas on detailing the locking end Jamb Frame.

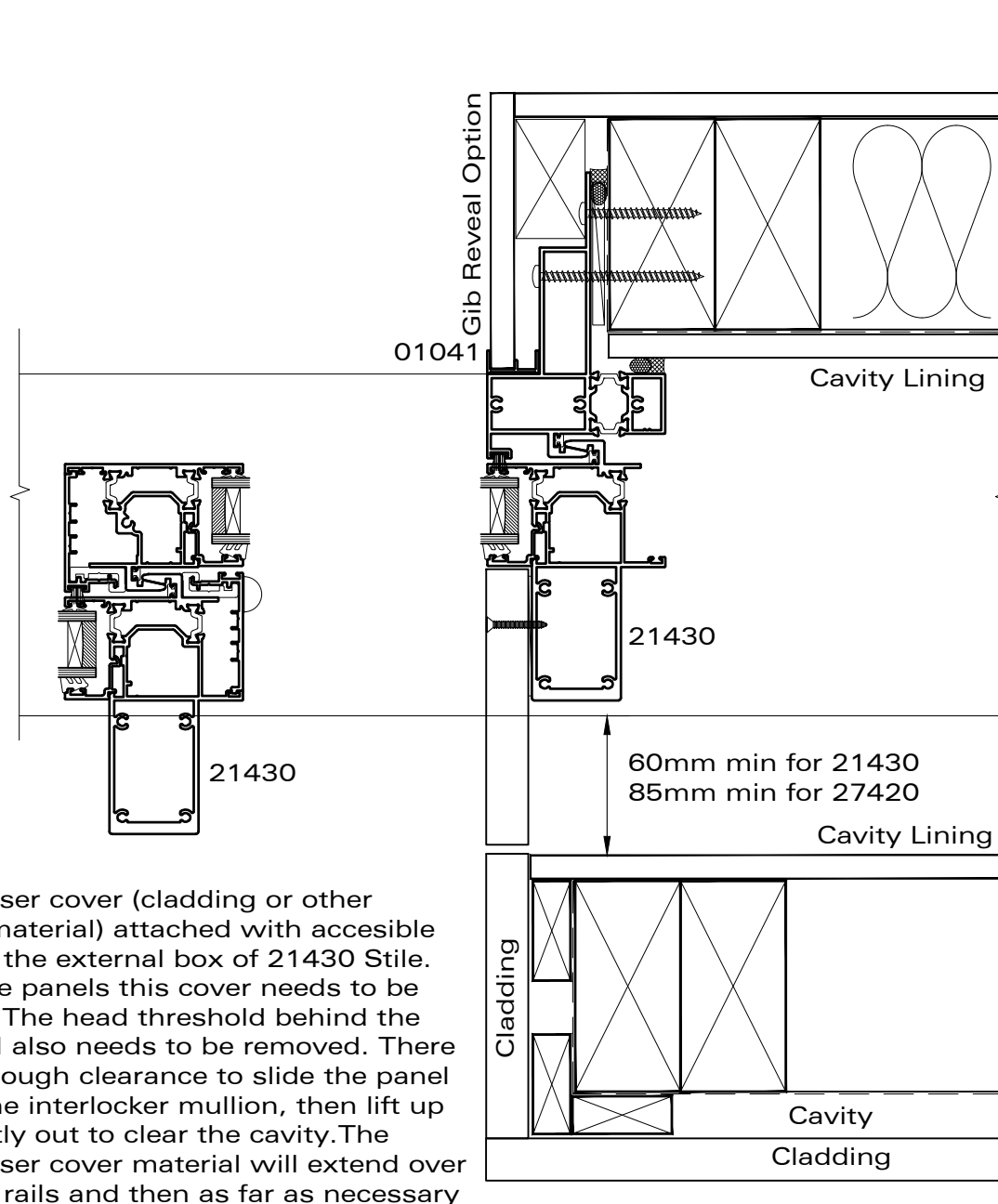

Cavity closer cover (cladding or other building material) attached with accessible fixings to the external box of 21430 Stile. To remove panels this cover needs to be removed. The head threshold behind the lock panel also needs to be removed. There is then enough clearance to slide the panel clear of the interlocker mullion, then lift up and slightly out to clear the cavity. The Cavity closer cover material will extend over the panel rails and then as far as necessary to blank off the cavity (see previous page).

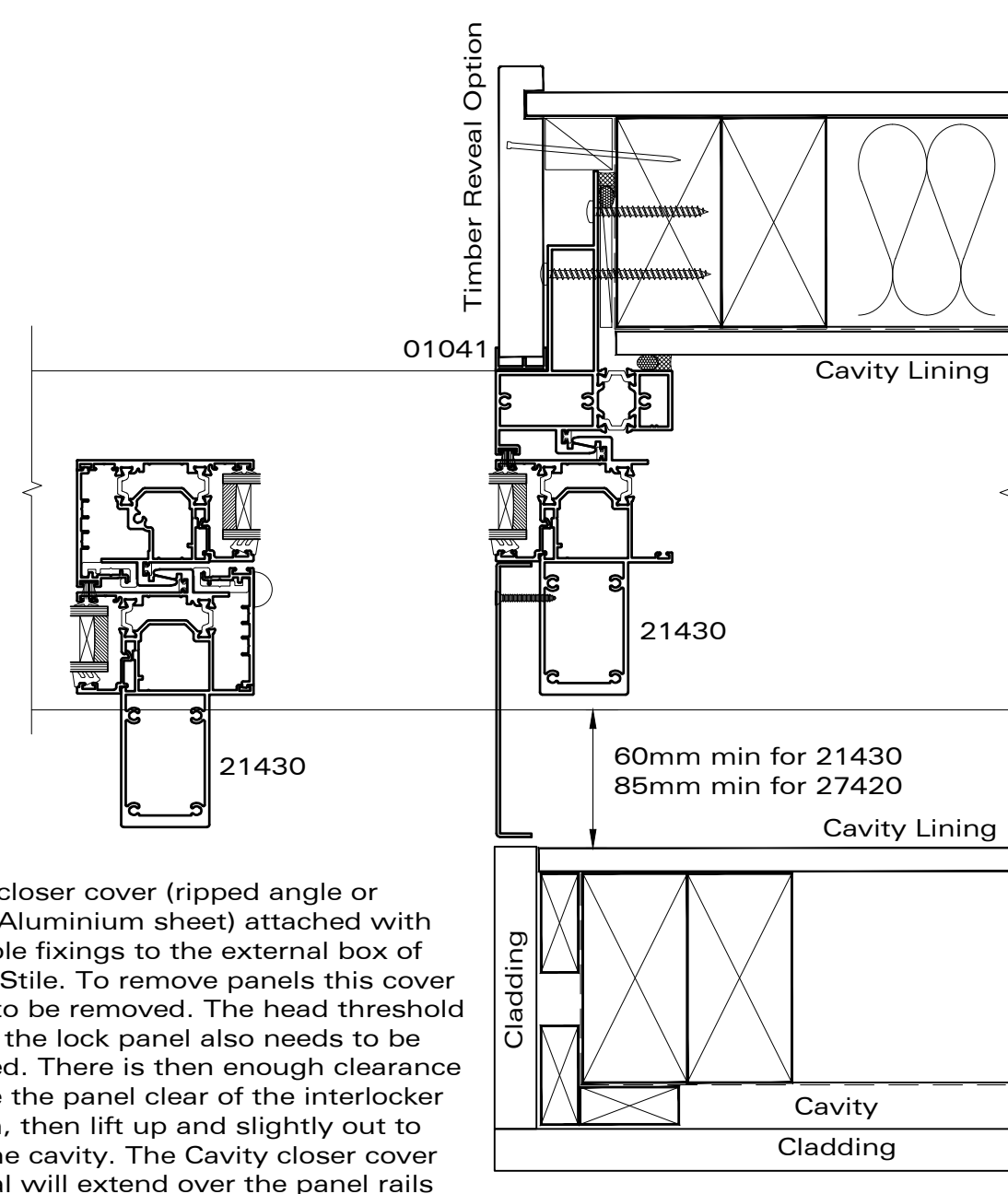

Cavity closer cover (ripped angle or folded Aluminium sheet) attached with accessible fixings to the external box of 21430 Stile. To remove panels this cover needs to be removed. The head threshold behind the lock panel also needs to be removed. There is then enough clearance to slide the panel clear of the interlocker mullion, then lift up and slightly out to clear the cavity. The Cavity closer cover material will extend over the panel rails and then as far as necessary to blank off the cavity (see previous page).