

# A900RS PROFILE BALUSTRADE RAIL OPTIONS

GLAZED

Cad Ref. APBA05-0    Scale 1:2    Date 01.01.09

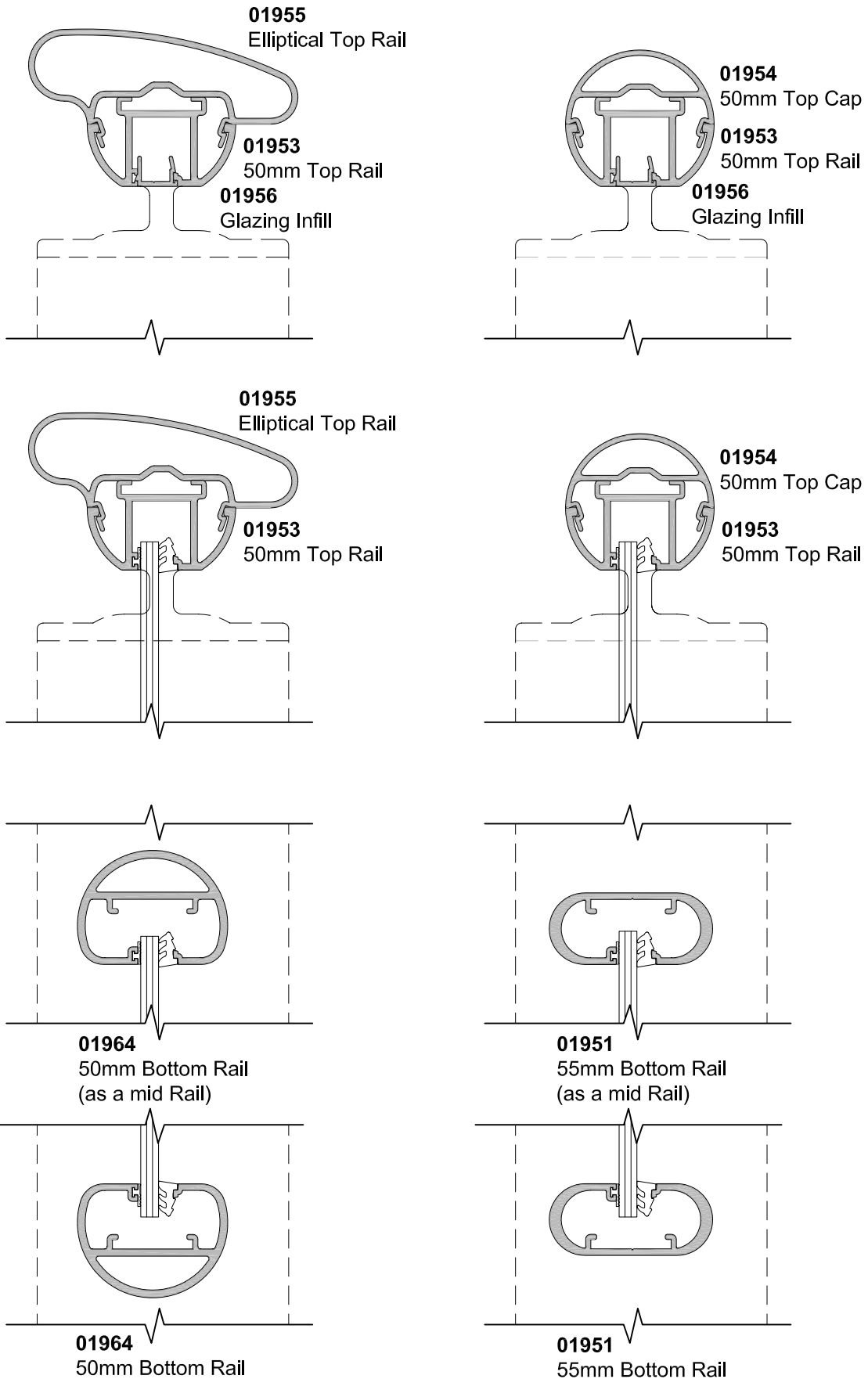

# A900RS PROFILE BALUSTRADE RAIL OPTIONS BALUSTER

Cad Ref. APBA06-0    Scale 1:2    Date 01.01.09

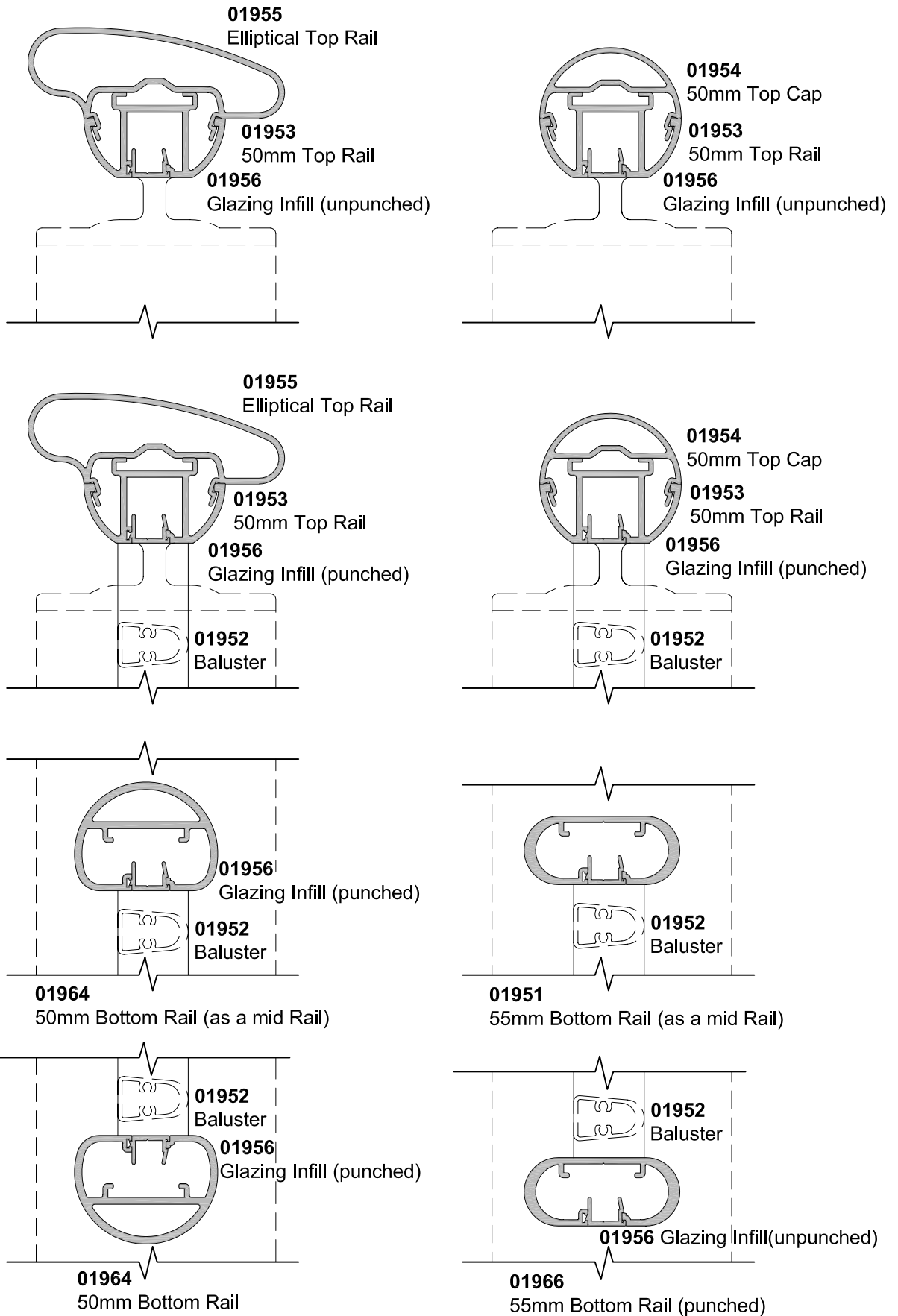

# A900RS PROFILE BALUSTRADE RAIL OPTIONS CURVED RAIL

Cad Ref. APBA07-0    Scale 1:2    Date 01.01.09

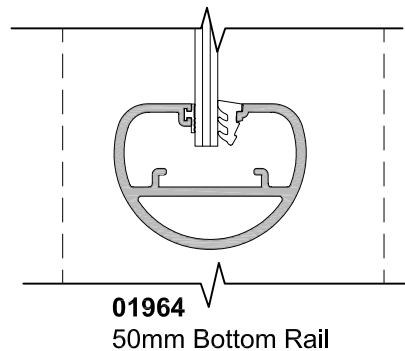
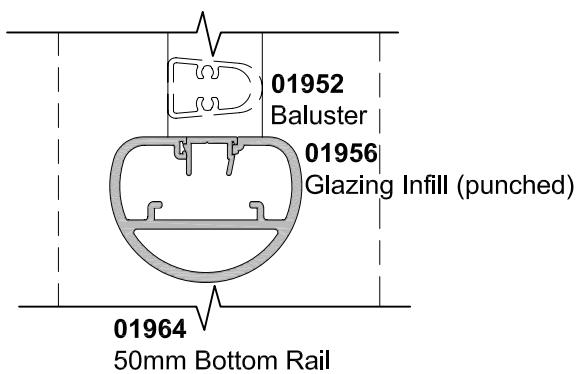
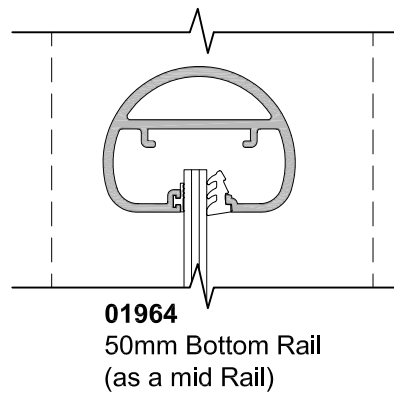
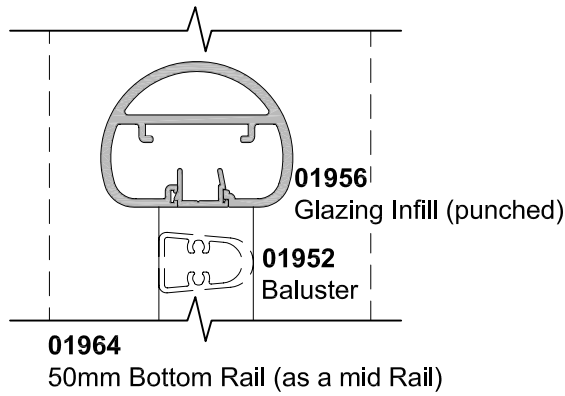
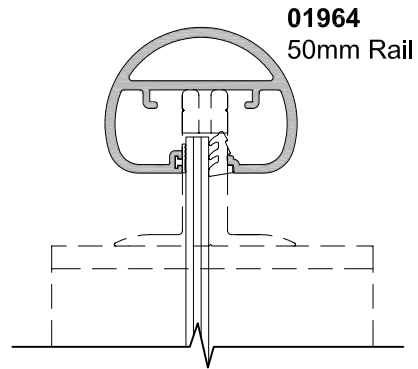
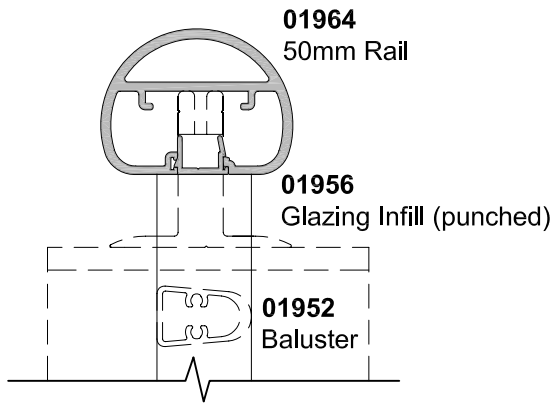
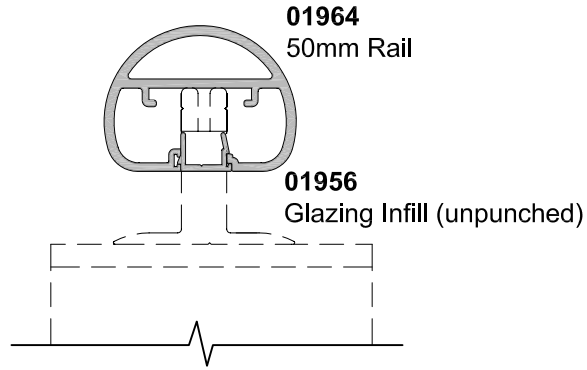

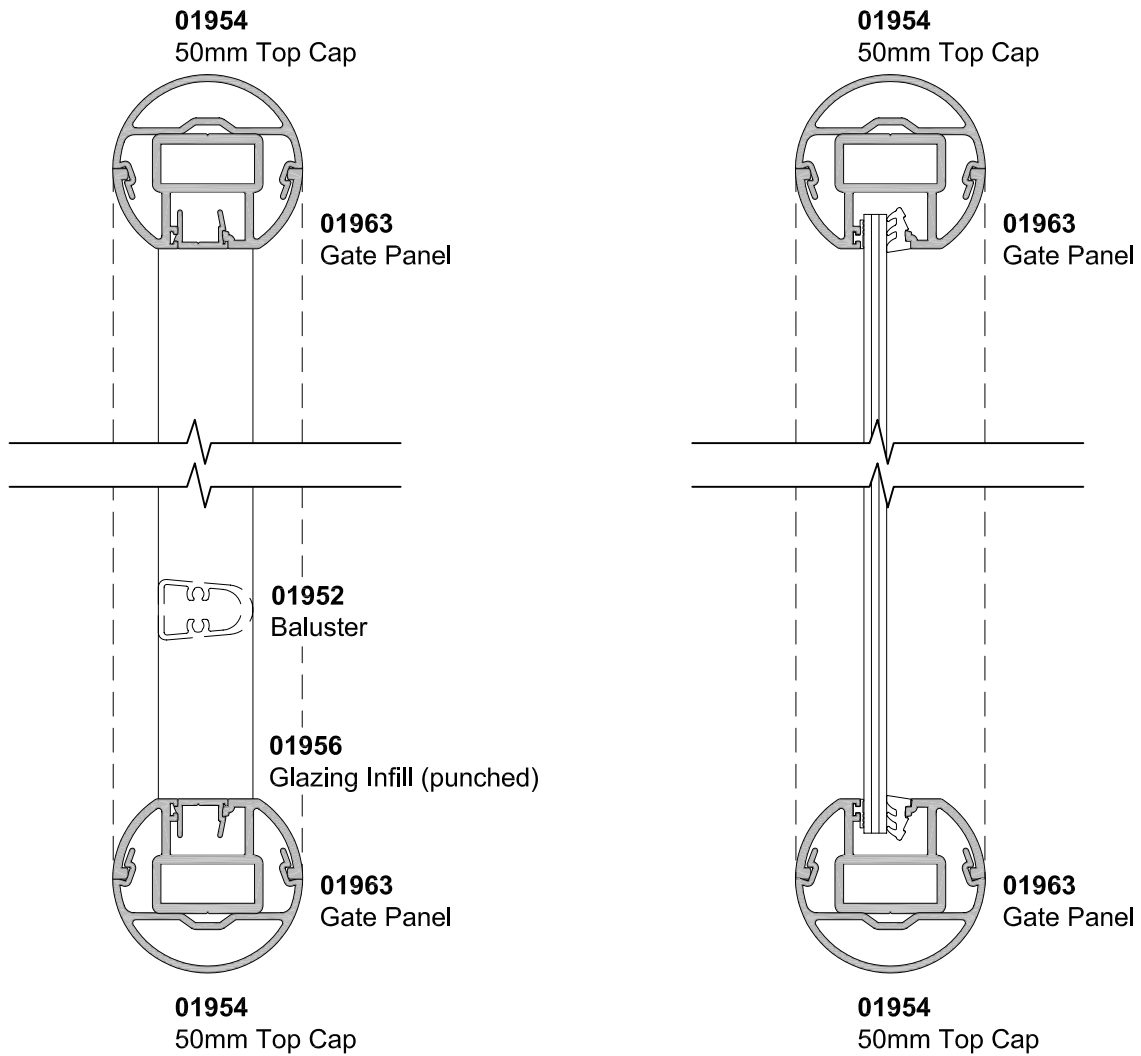

# A900RS PROFILE BALUSTRADE

## POST FOOTING OPTIONS

Cad Ref. APBA09-0    Scale 1:4    Date 01.01.09

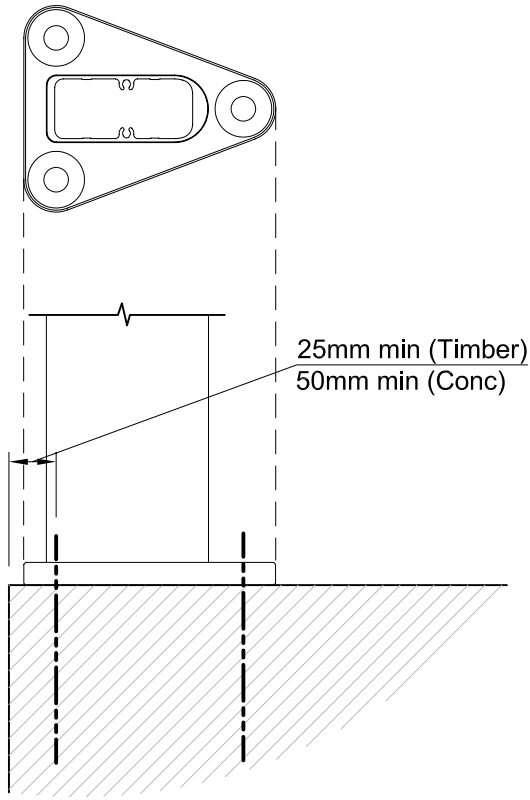

Standard Bracket (Supplied welded to Post)

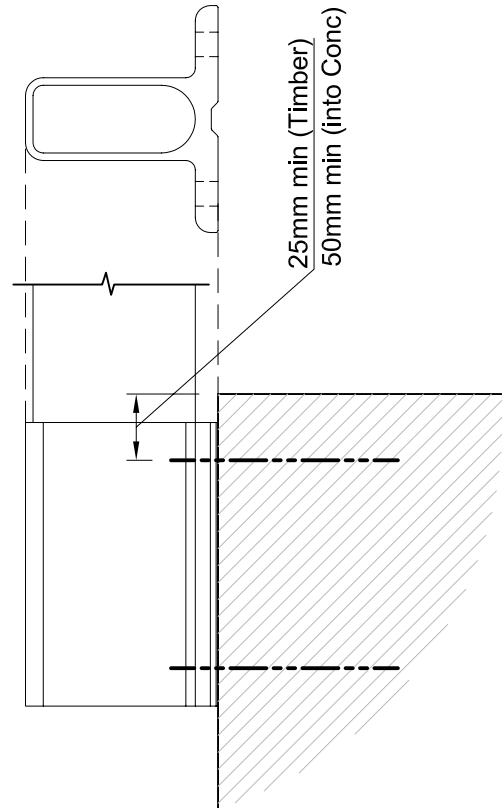

9100860 Face Fix Bracket

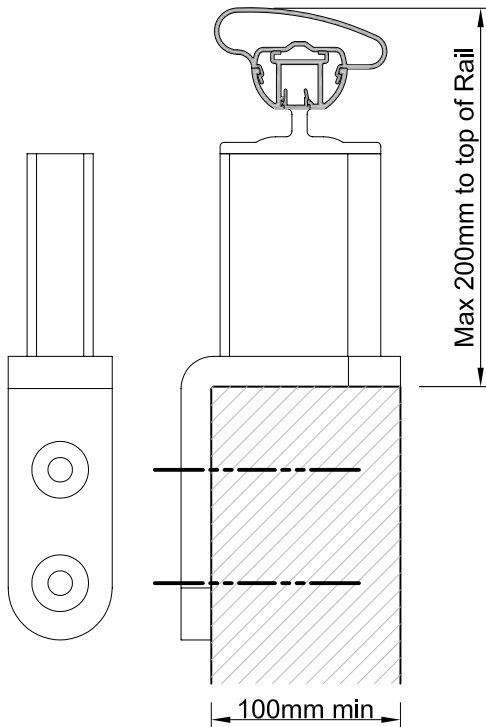

9100874 Nib Wall Bracket

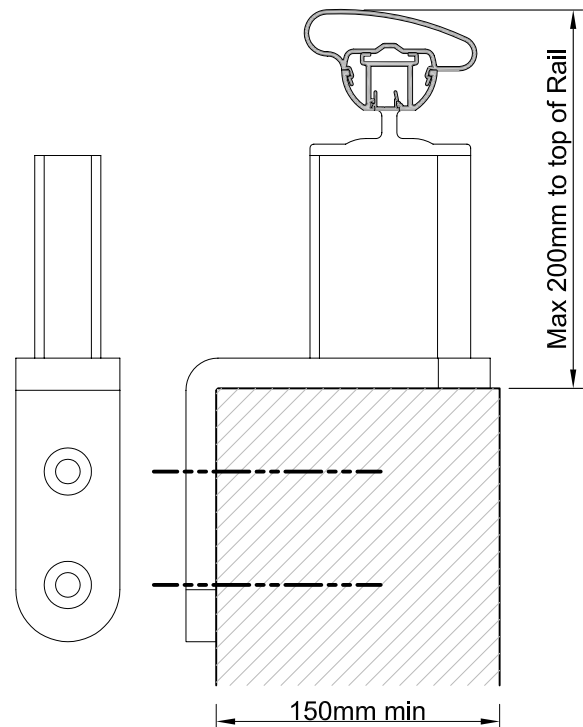

9100870 Nib Wall Bracket