

80MM SHOPFRONT A080SF MAGNUM 50 HINGED DOOR CROSS SECTION

Cad Ref. ACSF02-0 Scale 1:2 Date 01.01.09

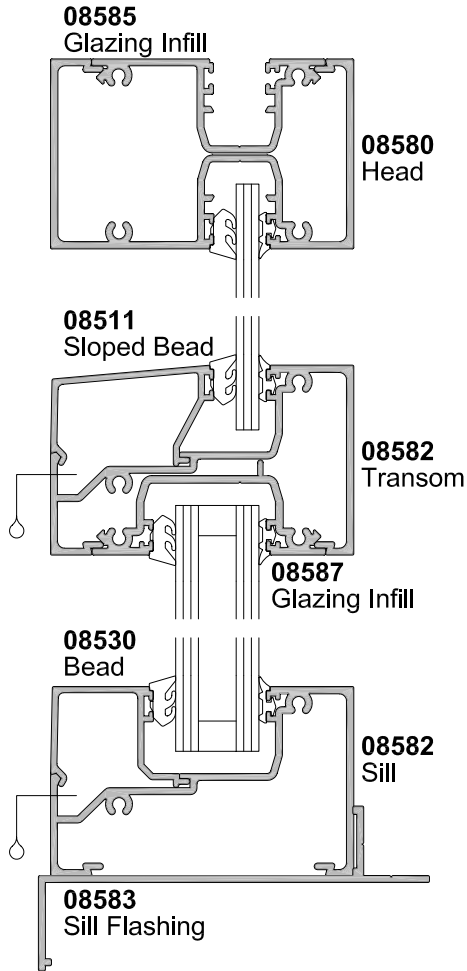

SECTION A-A

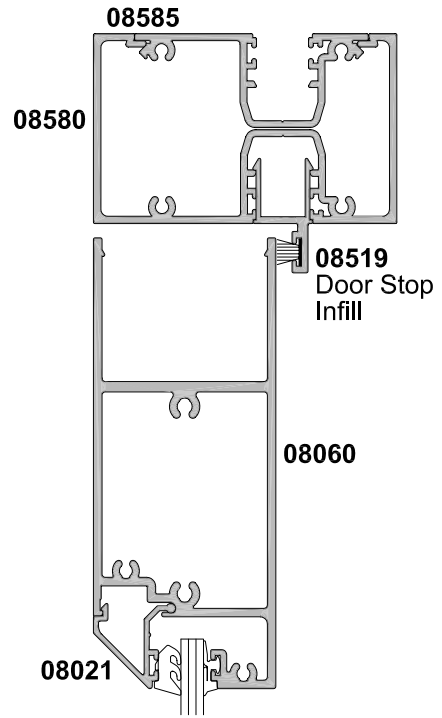

SECTION C-C

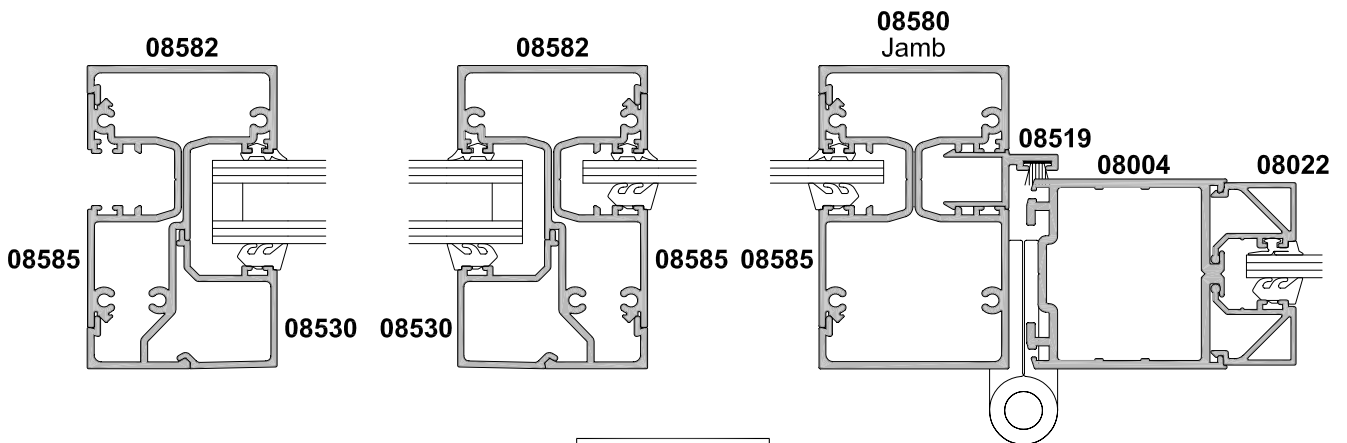

SECTION B-B

80MM SHOPFRONT, A080SF 40MM AWNING WINDOW AND MAGNUM 50 PIVOT DOOR

CROSS SECTION

Cad Ref. ACSF03-0 Scale 1:2 Date 01.01.09

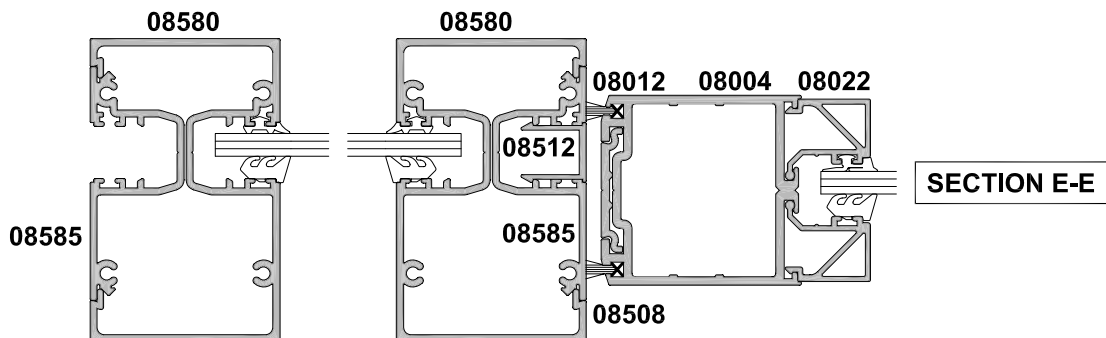
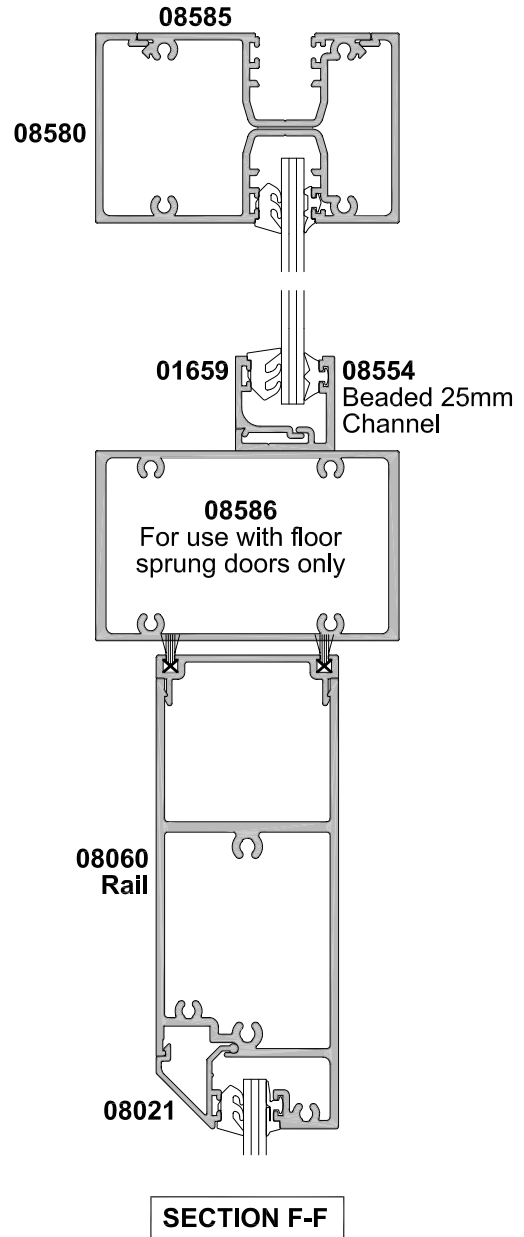
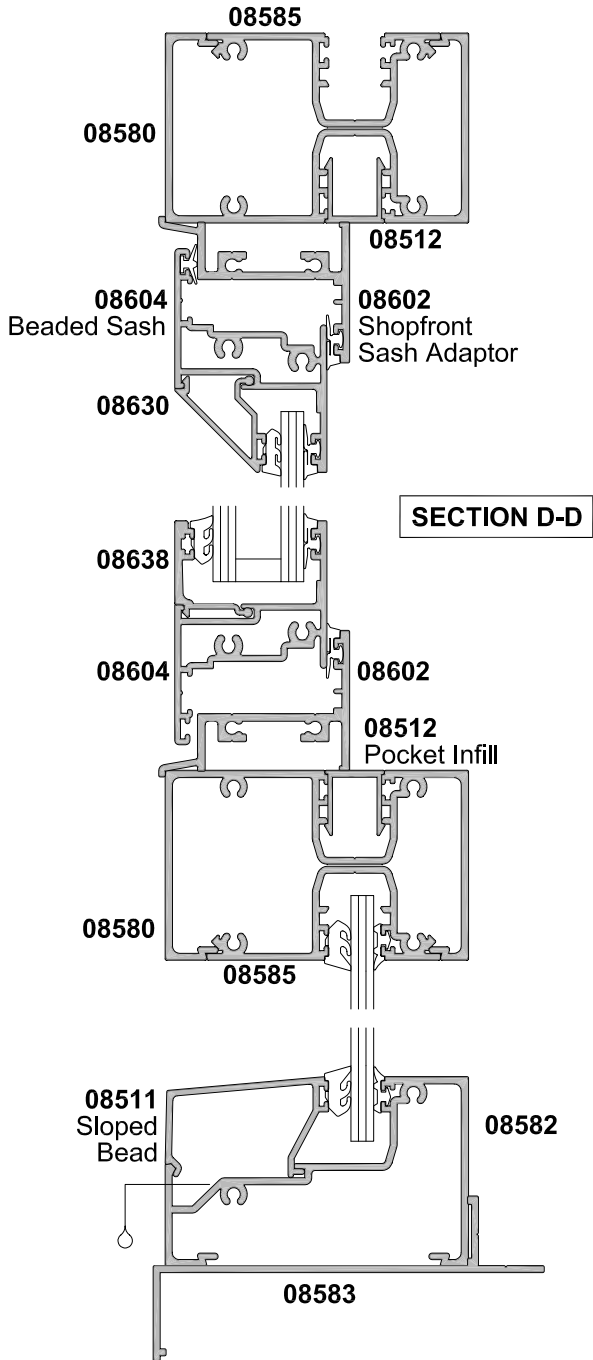

100MM SHOPFRONT A100SF MAGNUM 50 HINGED DOOR CROSS SECTION

Cad Ref. ACSF05-0 Scale 1:2 Date 01.01.09

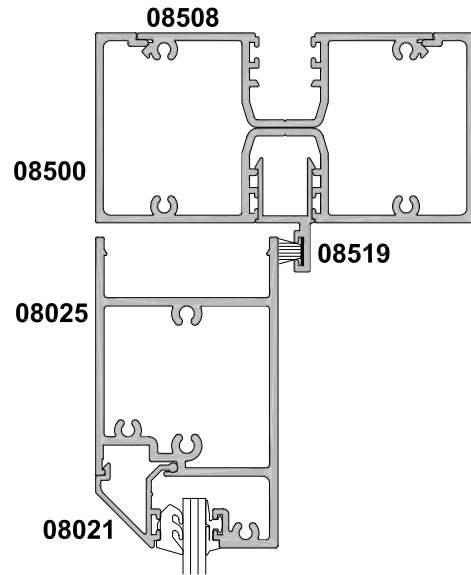
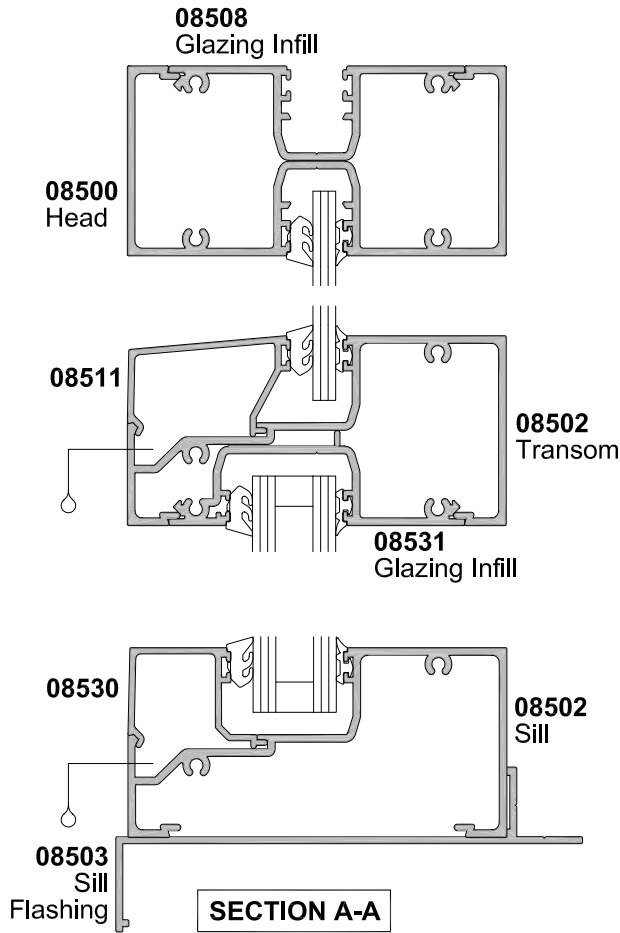

SECTION C-C

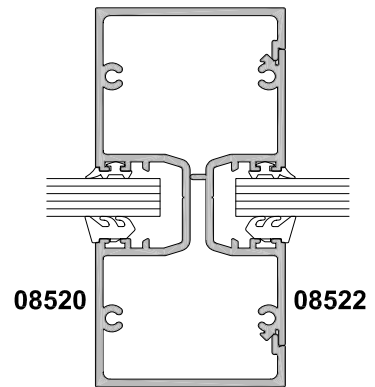

18mm POCKET OPTION

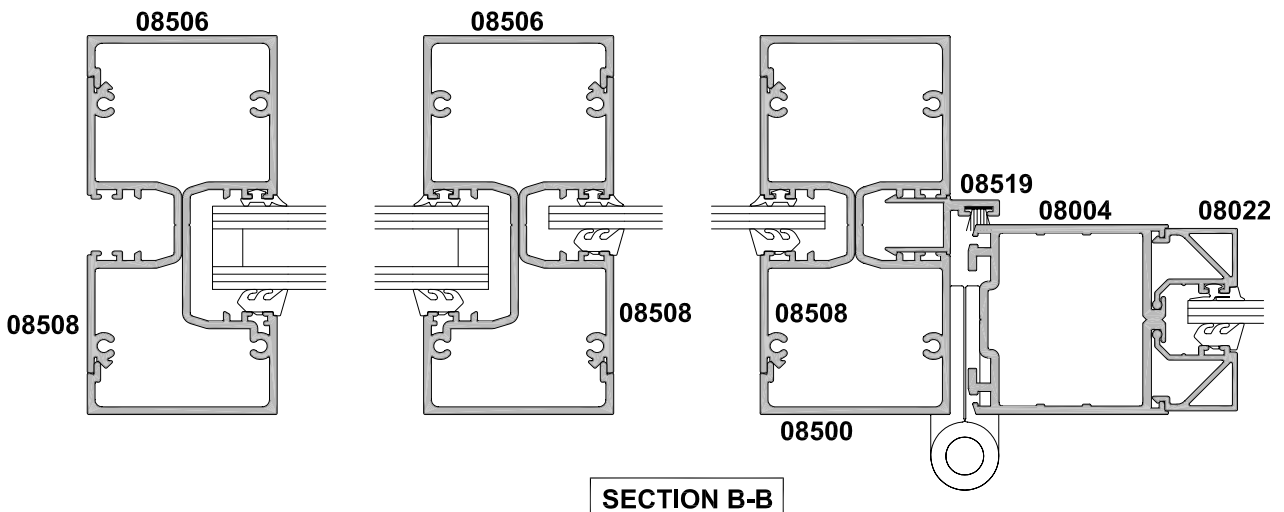

100MM SHOPFRONT, A100SF 40MM AWNING WINDOW AND MAGNUM 50 PIVOT DOOR

CROSS SECTION

Cad Ref. ACSF06-0 Scale 1:2 Date 01.01.09

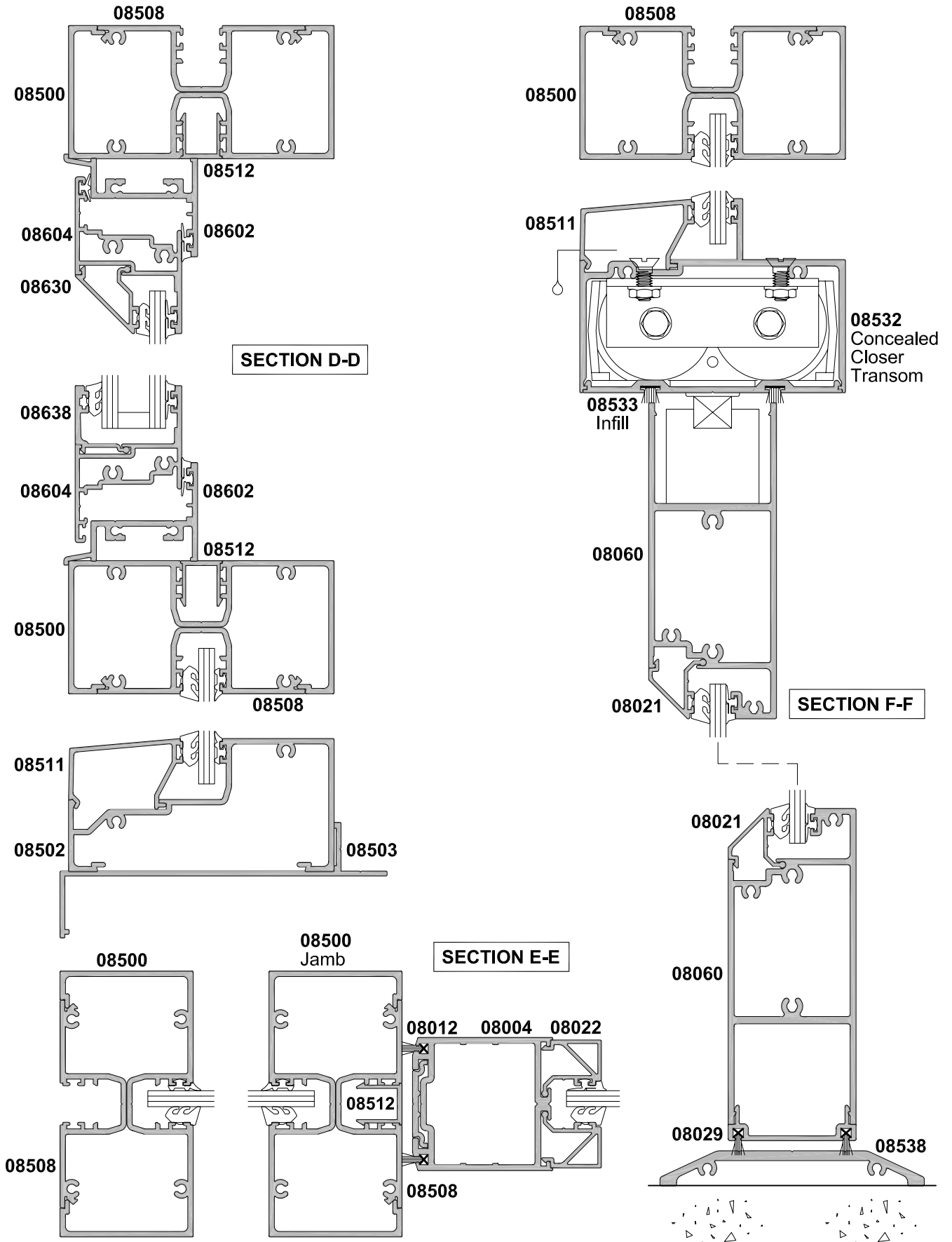

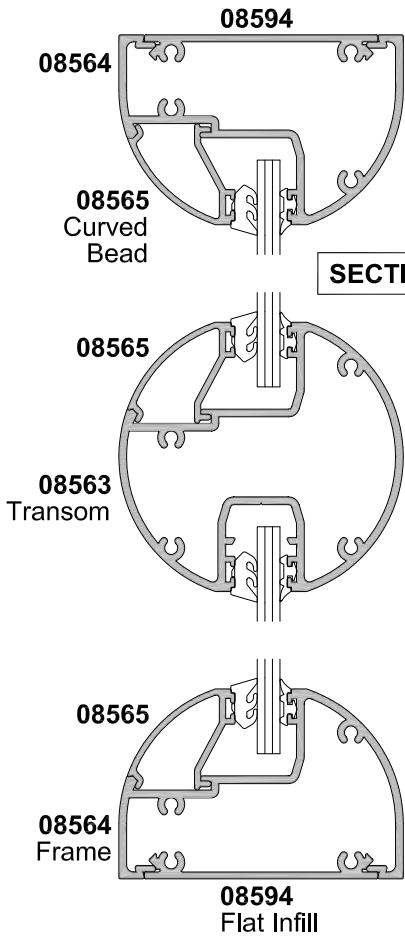

SECTION A-A

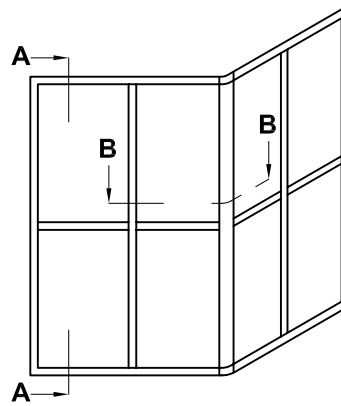

Note -

Only use this product for internal partitioning or external balustrade.

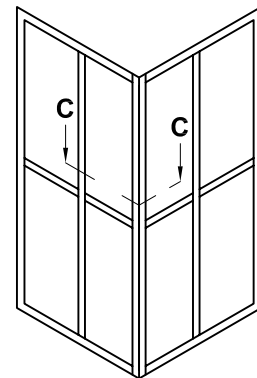

SECTION B-B

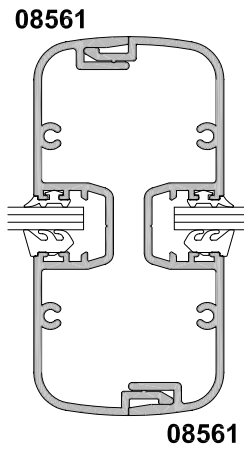

08561

08569
Male
Adjustable
Corner Post

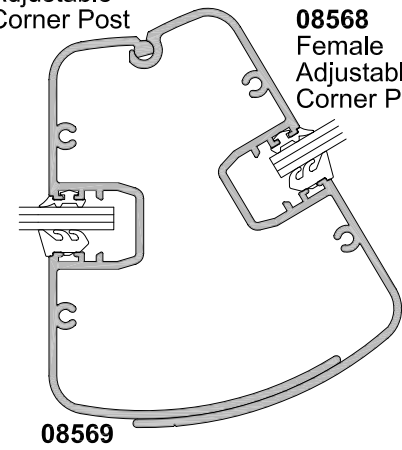

08569

08568
Female
Adjustable
Corner Post

SECTION C-C

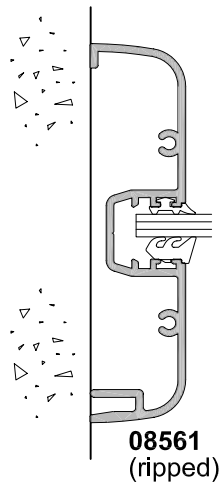

08561
(rippled)

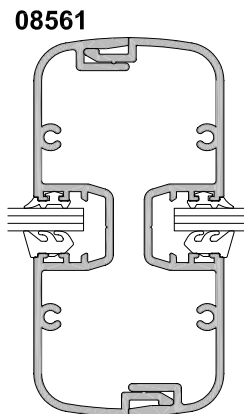

08561
Split Mullion

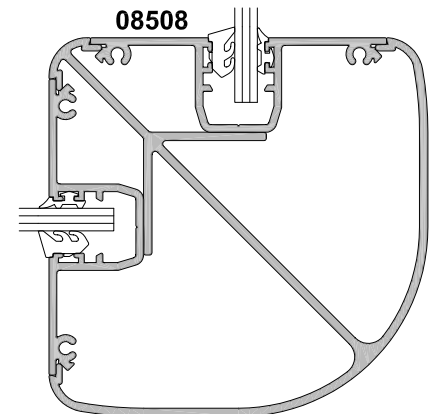

08508

08567
90° Corner Post

25MM GLAZING CHANNEL SUITE A110SF

CROSS SECTION

Cad Ref. ACSF09-0 Scale 1:2 Date 01.01.09

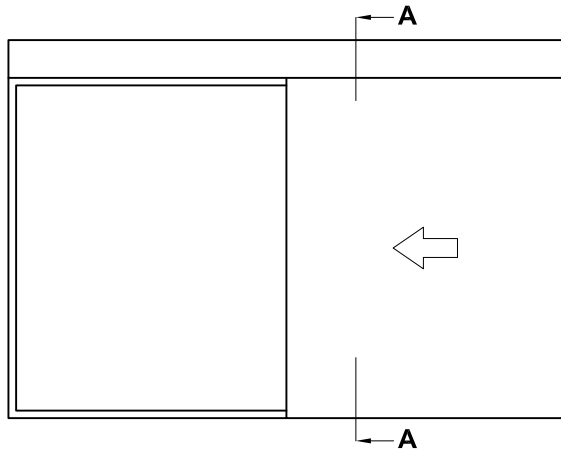

SLIDING DOOR

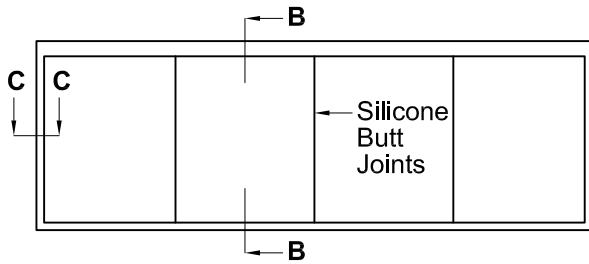

WINDOW

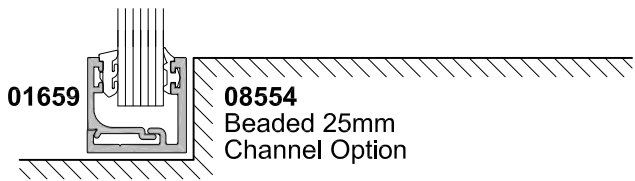
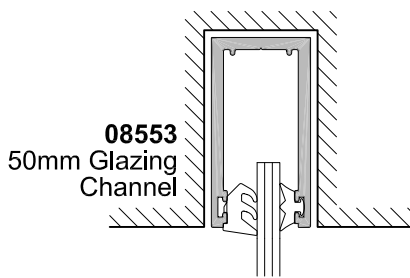
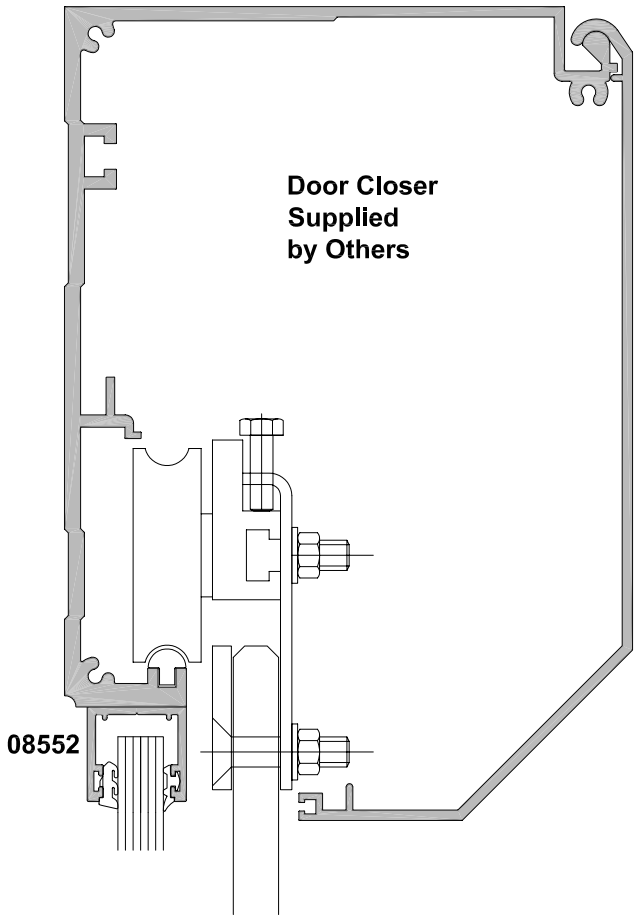

SECTION A-A

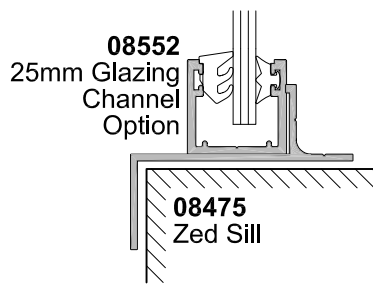

SECTION B-B

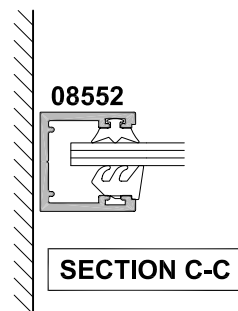

SECTION C-C