

Vertical Sliding Windows

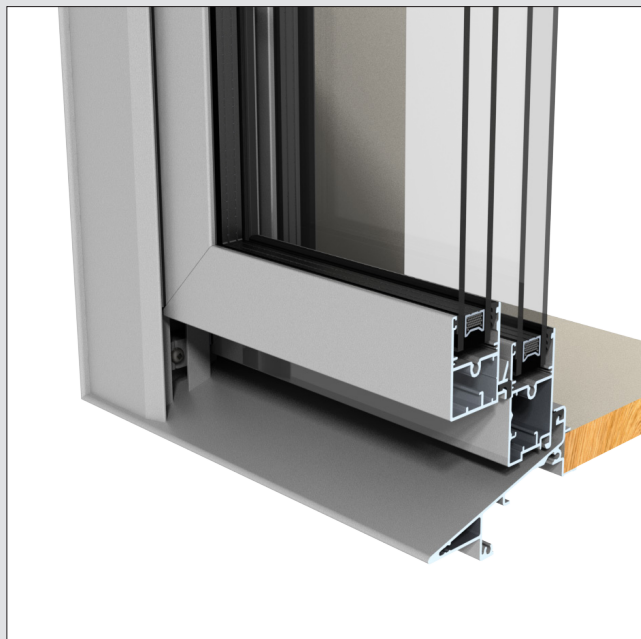

Contemporary frame and sashes.

Key Features

- A good option for non-projecting ventilation
- Colonial or contemporary frame option
- Easy cleaning feature for sash exterior
- Sloped sill and square cut jambs for traditional appearance
- Single or double glazed panel option available
- Both panels move independently
- Sash 'horns' for a colonial appearance can be fitted to the top sash
- Shugg window available where moving panes of glass substitute for aluminium sashes.

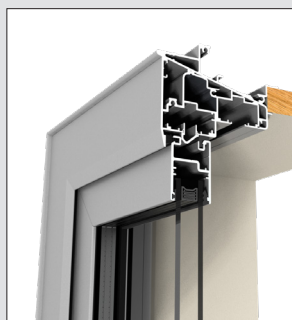

Contemporary frame at the head.

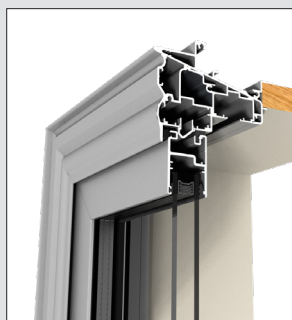

Colonial frame at the head.

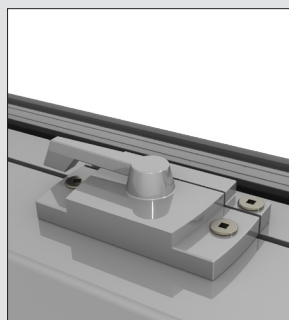

Swivel catch fitted on the top rail of lower sash.



Shugg window sill frame.

Specifications

Dimensions

Maximum size limited by coil spring weight restriction per sash of 12kg. Double glazed window 1500mm high x 600mm wide weighs approx. 10.5kg each (4mm single, 7.5kg).

Shugg windows have been tested at 1600mm high x 800mm wide but can be custom made

Maximum Glass Thickness

20mm IGU. Shugg windows - 21mm IGU

Thermal Values

U-value 6.569 **R-value** 0.152

Performance

Tested to Extra High wind zone

For Shugg windows refer to Neotec at shugg.co.nz

Design Considerations

- A good option where non-projecting windows are wanted
- Consider the ease of reaching to the window catch if the sliding panel is placed beyond a bench
- Work well with insect screens
- Opening gap at sill may need to be restricted in high window situations
- Inward opening feature for window cleaning needs to be done carefully and held by hand at all times
- Shugg windows need careful consideration before being fitted in exposed situations.