

dyson airblade tap

AB AB AB
09 10 11

Electrical

Input voltage/Frequency: 220-253V 50 Hz

Rated power: 1600 W

Motor type: Dyson digital motor – brushless DC Motor

Motor switching rate: 6,000 per second

Motor speed: 90,000 rpm

Operating temperature range: 0° – 40°C

Heater type: None

Standby power consumption: Less than 0.5 W

Construction

Tap construction: Stainless steel (brushed)

Under counter motor assembly construction: Moulded ABS (main unit)

Exterior screw type: Torx T15

Water ingress protection to IP35

Filter

HEPA filter (glass fibre and fleece prelayer)

Bacteria removal 99.9%

Operation

Touch-free infra-red activation

Hand dry time measurement: 12 seconds (Measurement based on National Sanitation Foundation Protocol P.335)

Operation lock-out period: 30 seconds

Airspeed at apertures: 690 km/h

Operating airflow: Up to 30 l/s

Water operation

Water flow rate: 4 l/min

Tap Aerator: Aerated water outlet

Tap power supply: Mains supply

Water temperature control: Thermostatic mixer recommended (not supplied)

Water pressure required: 1-8 Bar

Logistics

Serial number prefix: AB09 EC1; AB10 EC2; AB11 EC3

Single unit order code: AB09 300040-01; AB10 300041-01; AB11 300042-01

Net weight: AB09 4.3kg; AB10 4.6kg; AB11 TBC

Packaged weight: AB09 5.7kg; AB10 6.1kg; AB11 TBC

Packaged dimensions: AB09 H303 × W284 × D286 mm

AB10 H276 × W437 × D280 mm; AB11 H302 × W610 × D375 mm

Unit barcode: AB09 5025 1550 158 03; AB10 5025 1550 158 10; AB11 5025 1550 158 10

Standard guarantee

5 year guarantee



Product range

AB09 Short



AB10 Long



AB11 Wall



The Planet Ark Carbon Reduction Label is the registered trade mark of the Carbon Trust.

For further information please contact Dyson.
1800 Hand Dryer/ 1800 426 337 (AU) 0800 397 667 (NZ)
www.dysonairblade.com.au (AU)
www.dysonairblade.co.nz (NZ)

dyson airblade tap

TECHNICAL SPECIFICATION

AB
09 10 11



FRONT ELEVATION

SIDE ELEVATION

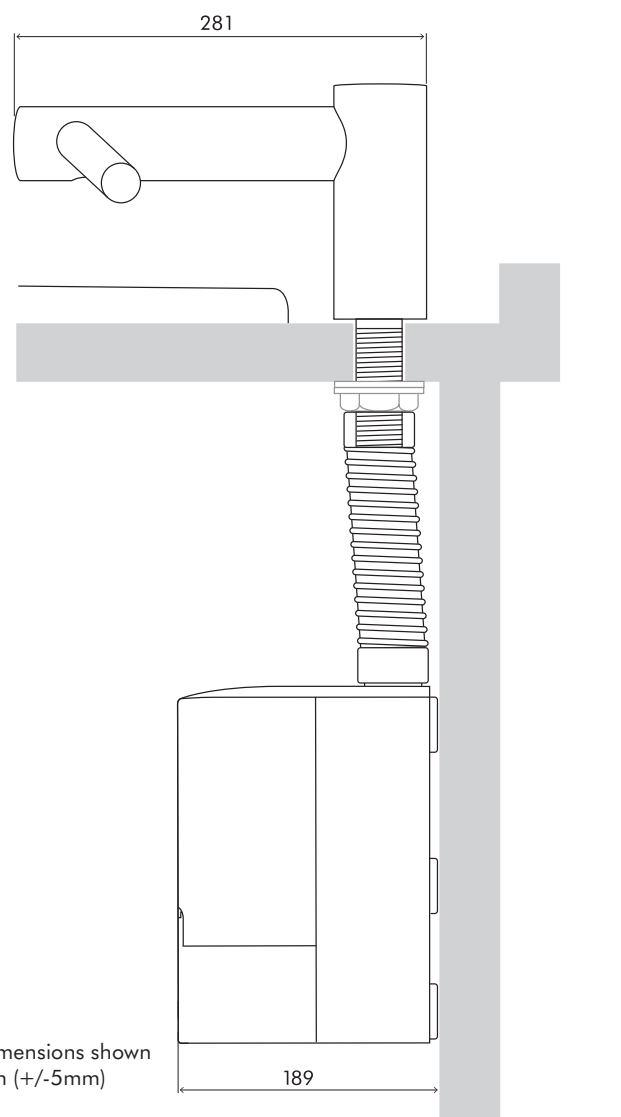
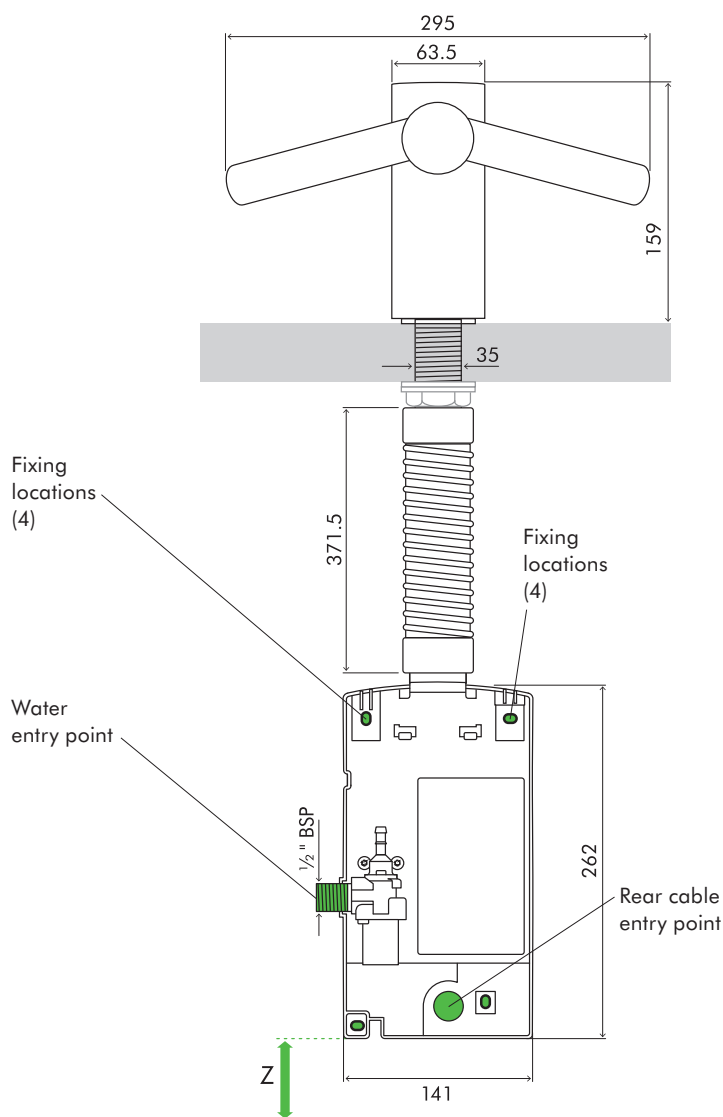

All dimensions shown in mm (+/-5mm)

FLOOR

Tap dimensions

AB09 Height 159mm Width 295mm Depth 281mm

Motor bucket dimensions

AB09 Height 262mm Width 141mm Depth 189mm

Minimum clearance

Z 100mm clearance from floor.

For further information please contact Dyson.
1800 Hand Dryer/ 1800 426 337 (AU) 0800 397 667 (NZ)
www.dysonairblade.com.au (AU)
www.dysonairblade.co.nz (NZ)

dyson airblade tap

TECHNICAL SPECIFICATION



AB 09 AB 10 AB 11

FRONT ELEVATION

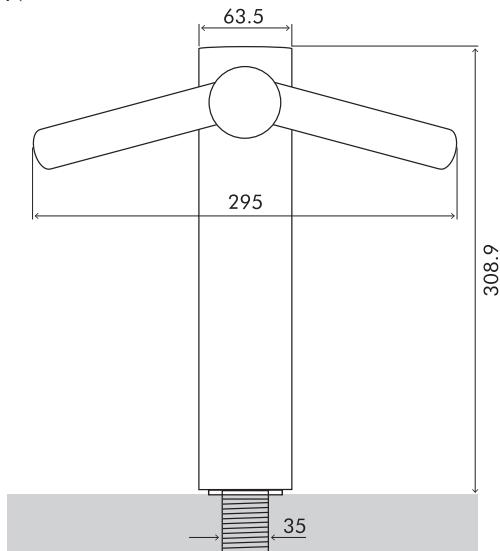

SIDE ELEVATION

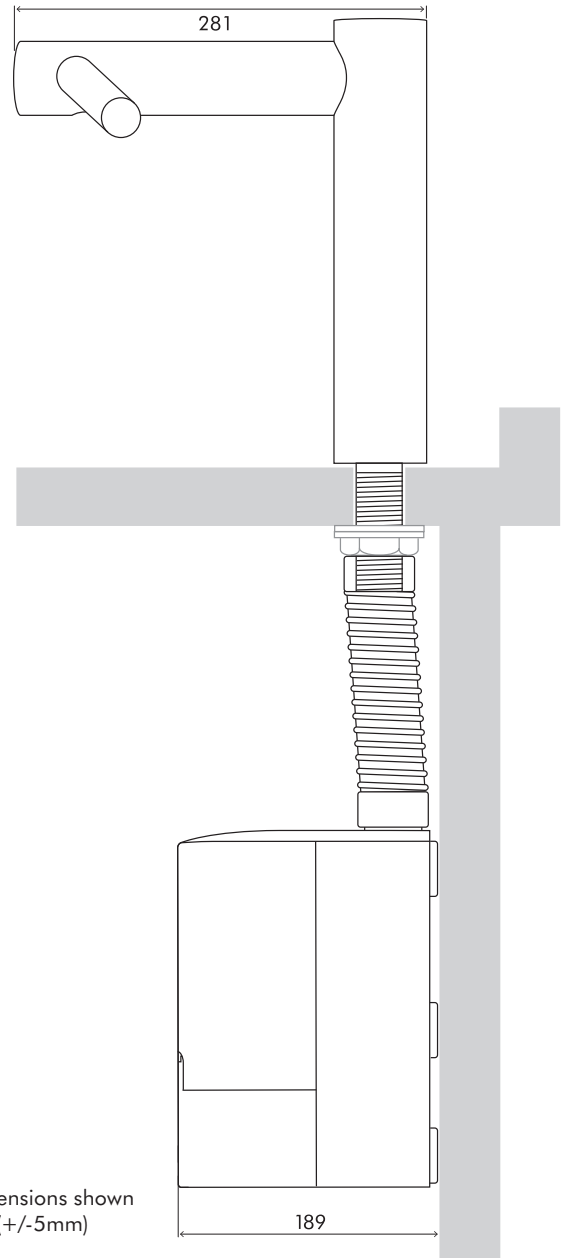

Fixing locations (4)

Fixing locations (4)

Water entry point

1/2" BSP

Rear cable entry point

Z

All dimensions shown in mm (+/-5mm)

FLOOR

Tap dimensions

AB10 Height 308mm Width 295mm Depth 281mm

Motor bucket dimensions

AB10 Height 262mm Width 141mm Depth 189mm

Minimum clearance

Z 100mm clearance from floor.

For further information please contact Dyson.

1800 Hand Dryer/ 1800 426 337 (AU) 0800 397 667 (NZ)

www.dysonairblade.com.au (AU)

www.dysonairblade.co.nz (NZ)

dyson airblade tap

TECHNICAL SPECIFICATION

AB
09 AB
10 AB
11



FRONT ELEVATION

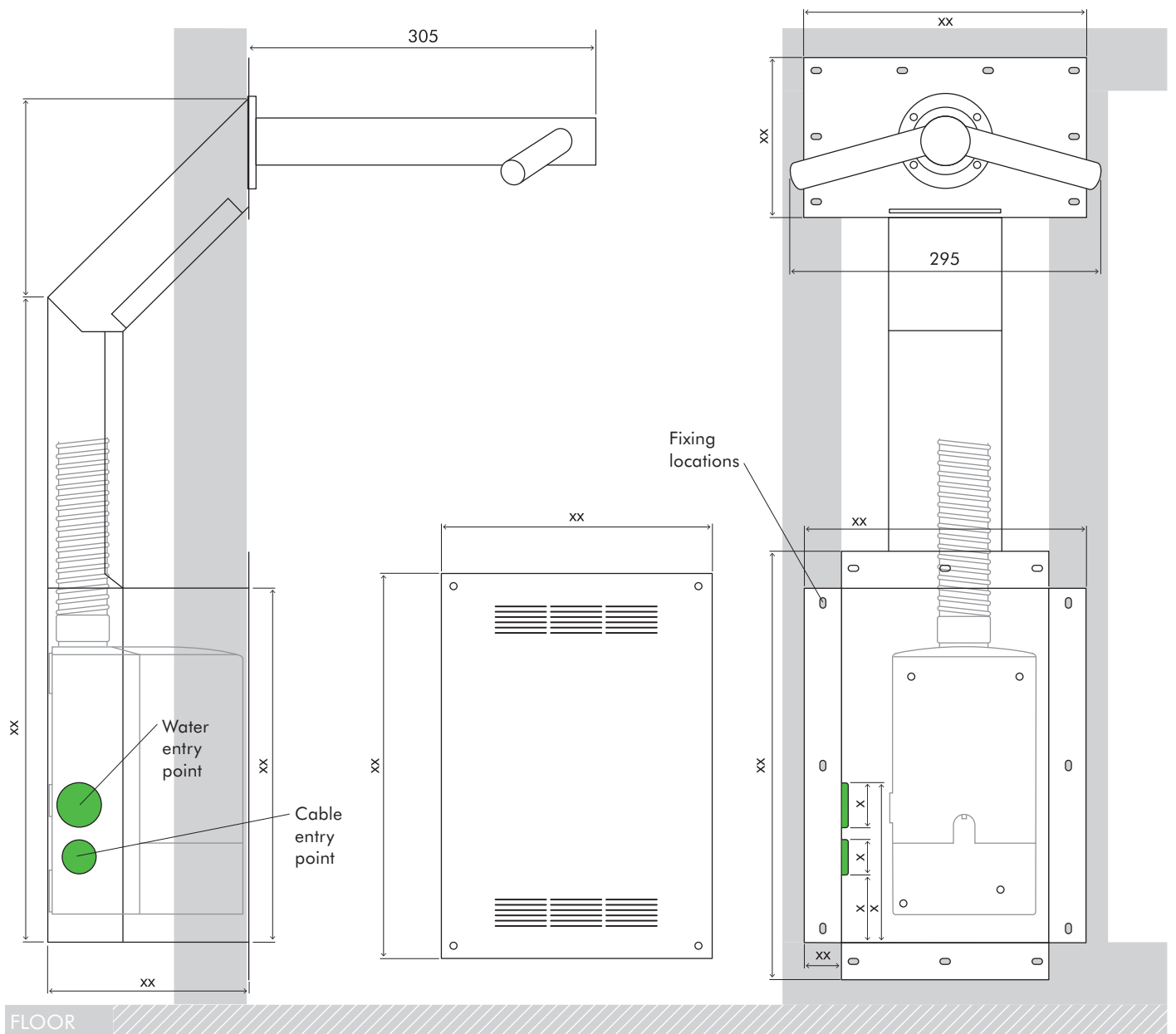

Tap dimensions

AB11 Length 305mm Width 295mm

Motor bucket dimensions

AB11 Height 262mm Width 141mm Depth 189mm

For further information please contact Dyson.
1800 Hand Dryer/ 1800 426 337 (AU) 0800 397 667 (NZ)
www.dysonairblade.com.au (AU)
www.dysonairblade.co.nz (NZ)