

WN 05634245532  
05/04

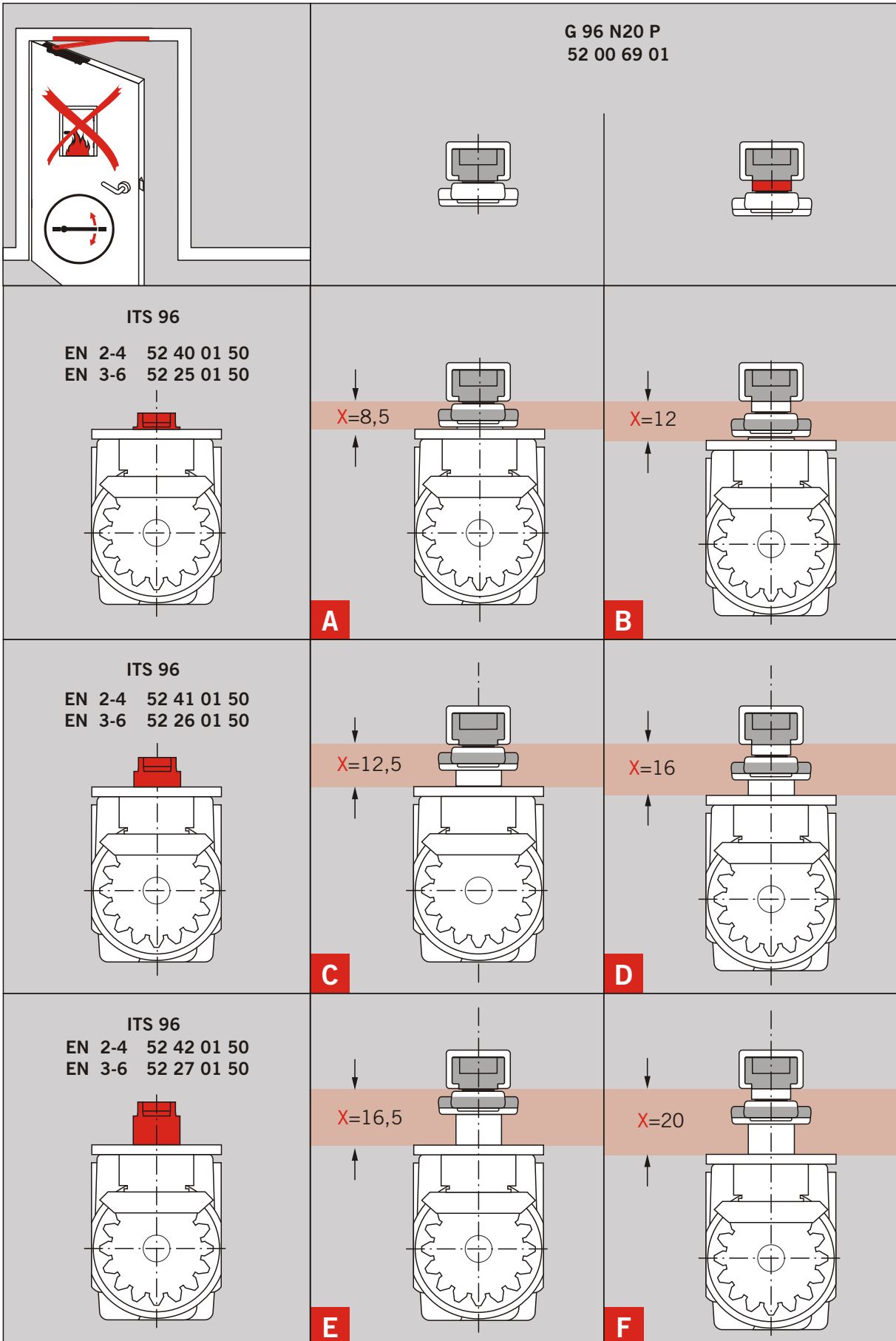

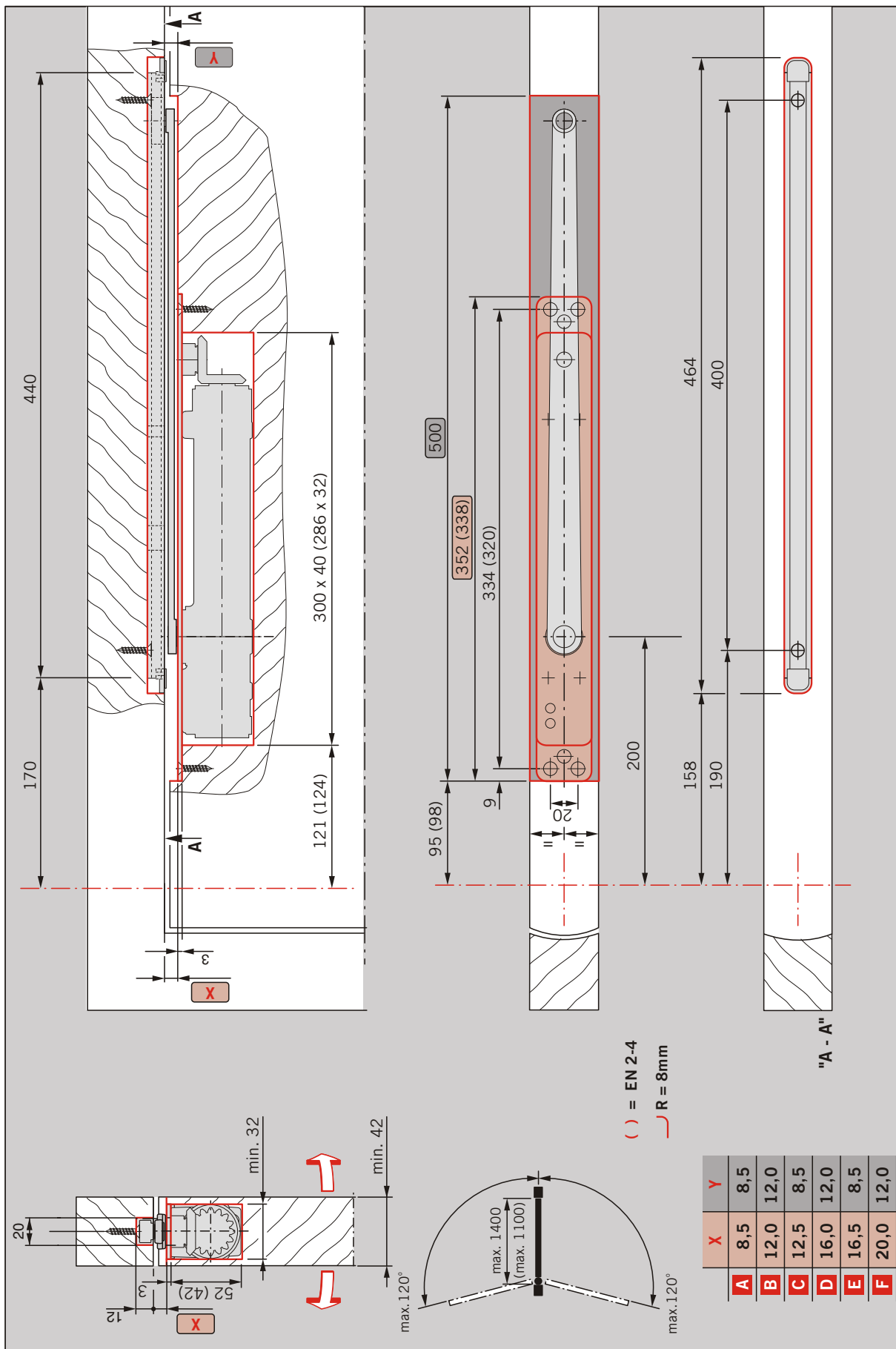

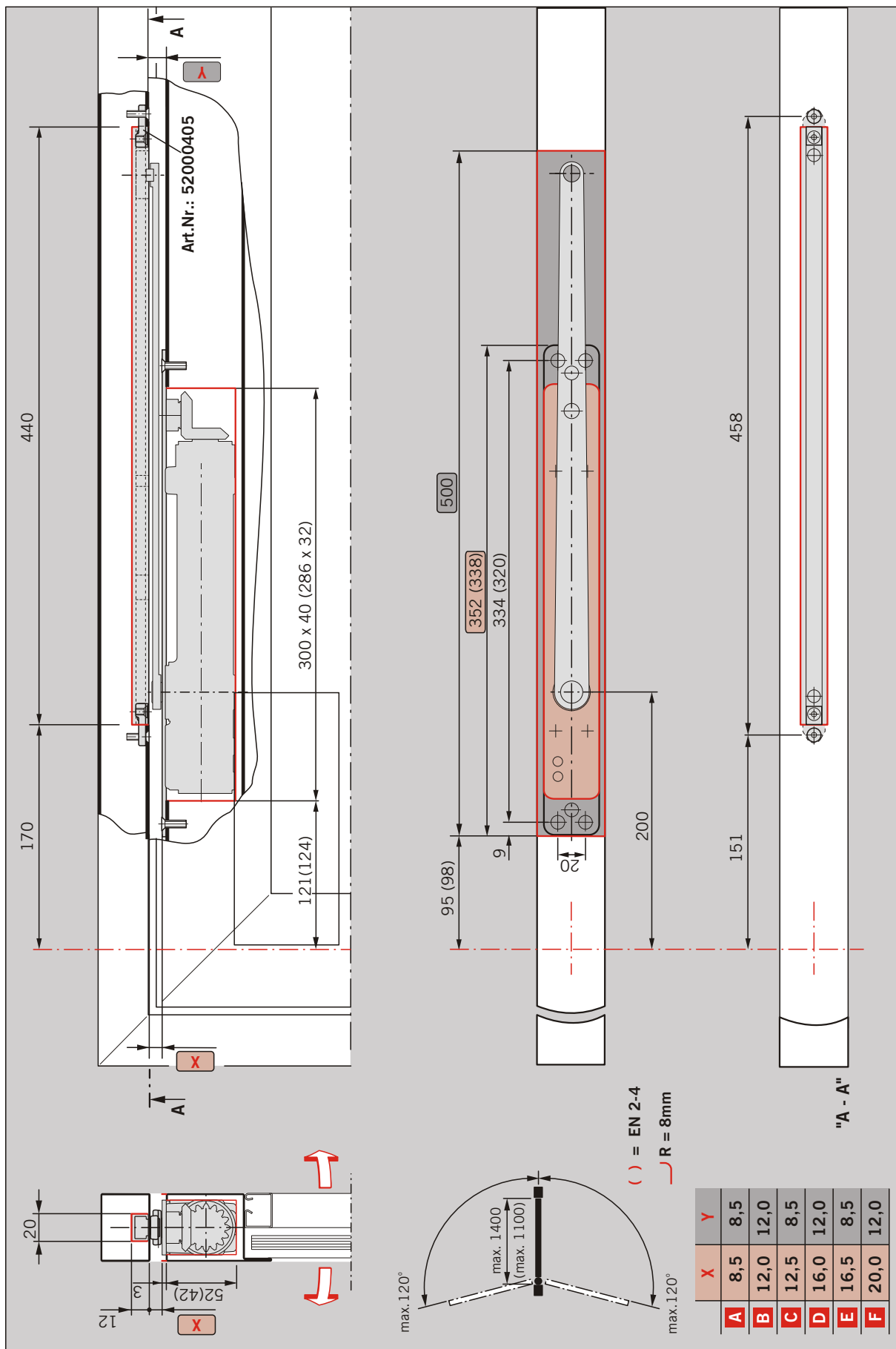

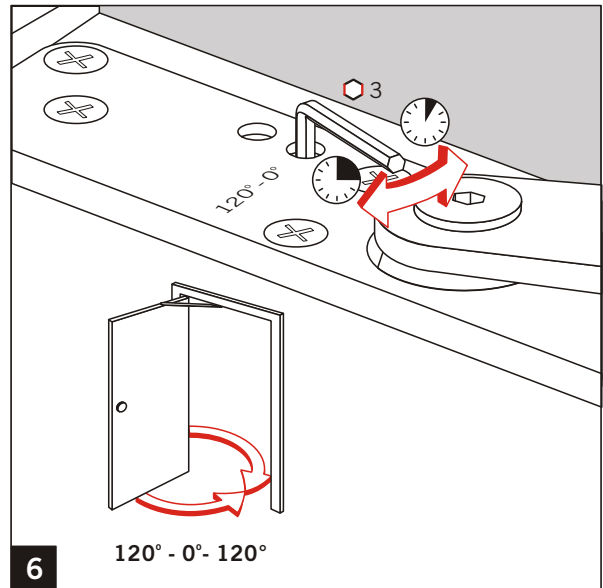
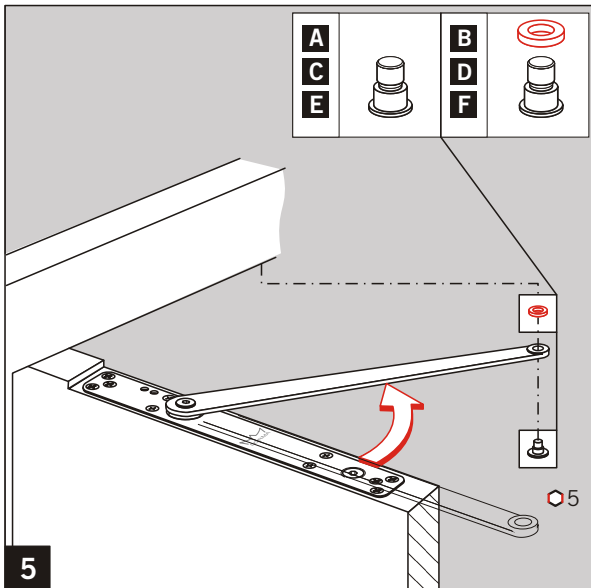
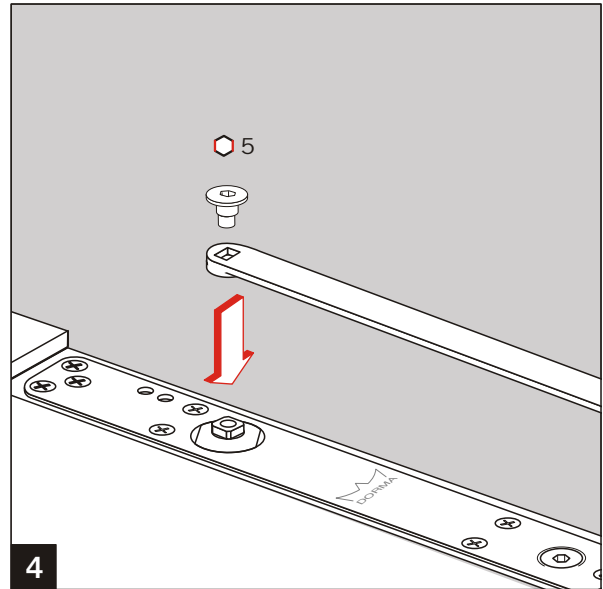
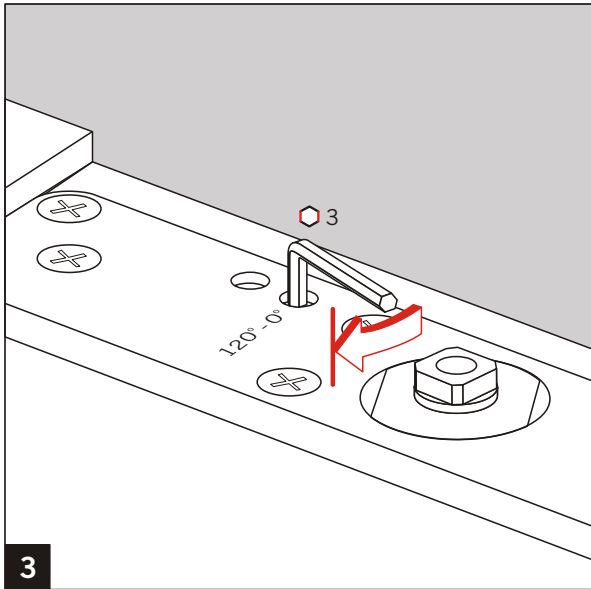
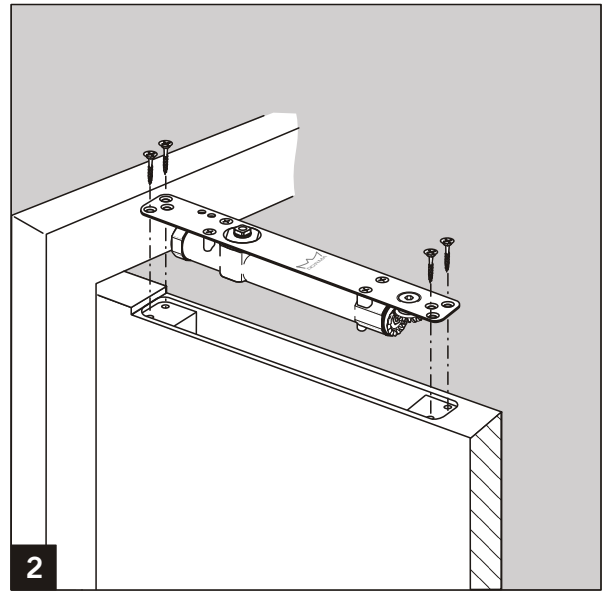
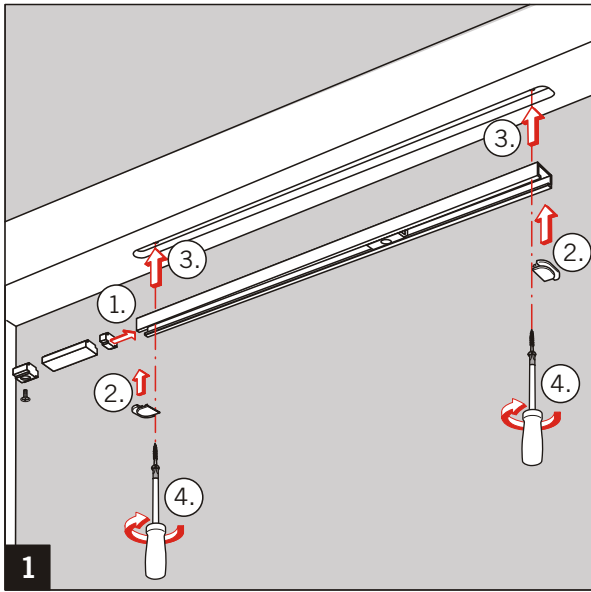

	X1	X2 max.
EN 2-4	850 mm	1100 mm
EN 3-6	950 mm	1400 mm



7

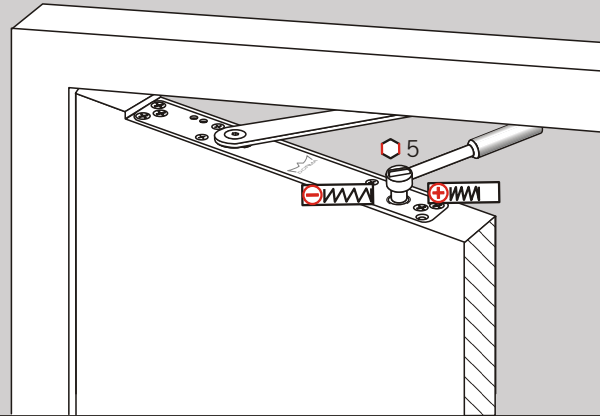

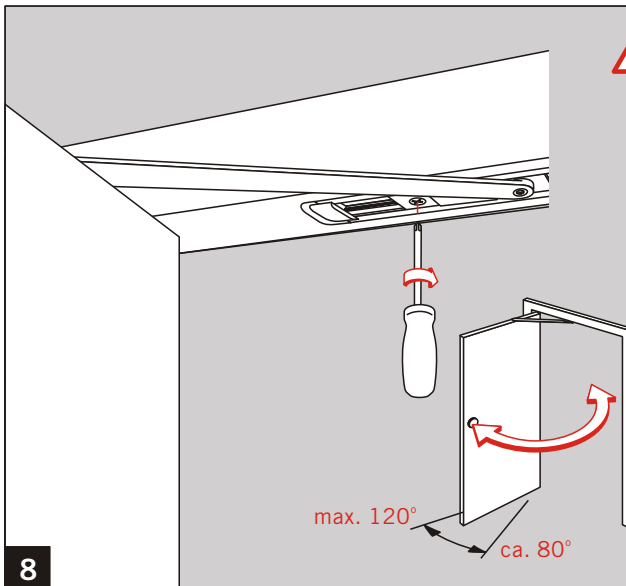

**!** Durch den Einsatz der Öffnungsbegrenzung soll verhindert werden, daß eine **normal** geöffnete Tür gegen angrenzende Wände stößt. Sie ist keine Überlastsicherung und ersetzt in vielen Anwendungsfällen nicht einen Türstopper. Öffnungsbegrenzung einstellbar zwischen 80° und max. 120°.

The deadstop helps to prevent damage to the door and wall when the door is opened **normally**. The deadstop is not abuse resistant, and cannot replace a door stop in many situations. Deadstop adjustable between 80° and 120° maximum.

La butée de limitation à l'ouverture réduit considérablement les risques d'endommagement du mur ou de la porte en ouverture **normale**. La butée de limitation à l'ouverture ne remplace pas le butoir de porte. Butée de limitation à l'ouverture. Réglable entre 80° et 120° maximum.

D

GB

F