

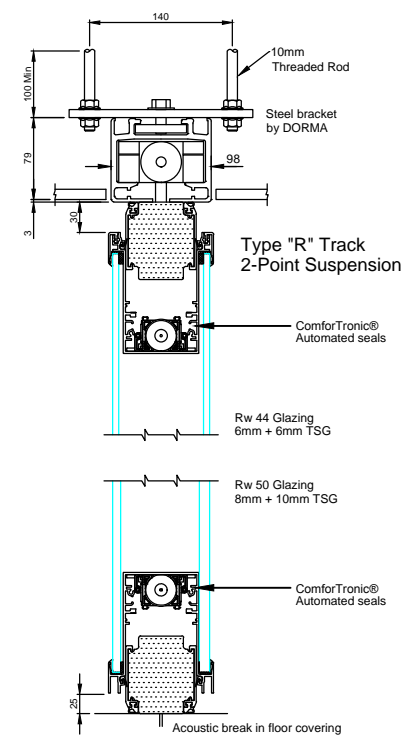

DORMA Movable Walls Pty Ltd
Web site: www.dorma.com.au

Panel construction



Standard panel joint

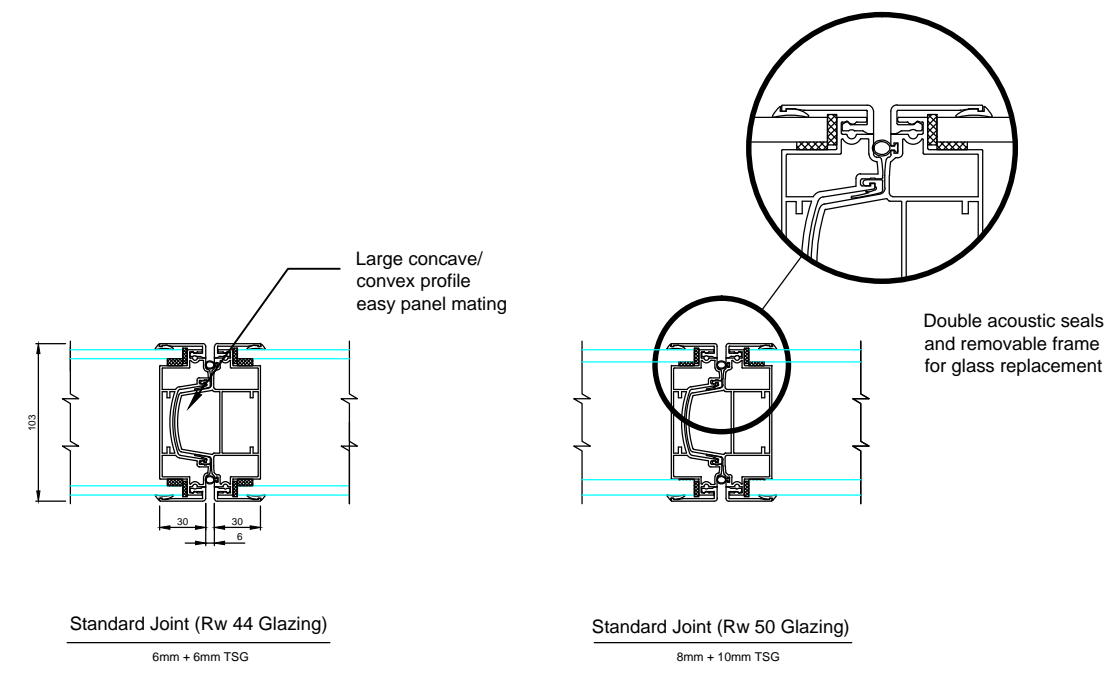

Typical configurations (AWA Closure)

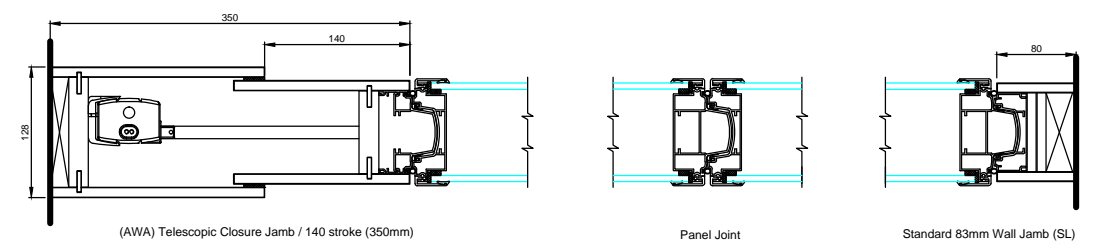

Typical Elevation / Wiring Configuration

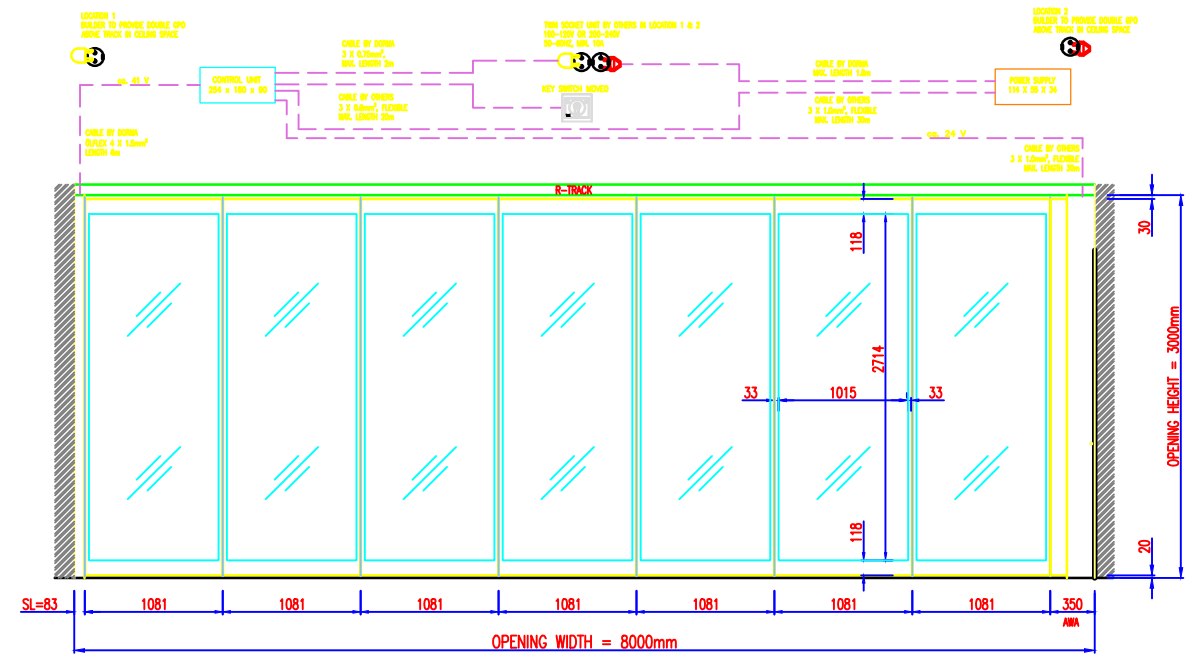

PROJECT NUMBER:

PROJECT NAME:

TITLE: HEAD & PANEL DETAILS

PRODUCT: MOVEO GLASS

DRAWING NUMBER:	SCALE	REVISION
D4	NTS	

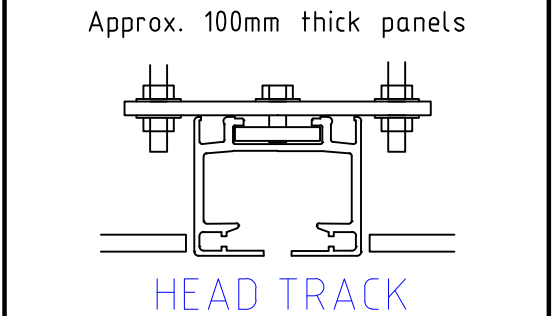

DRAWN BY (PRINT & SIGN): MA
DATE: 06/09/2013

APPROVED BY: _____

DATE: _____

No	REVISION	DATE
A		
B		
C		
D		
E		