

EURO WALL ANGLE SEAM HORIZONTAL

Originating in Europe this profile contributes to a pleasing wide pan tray and is available in a seam height of 25mm and 38mm. The Angle Seam profile is fixed to a substrate with concealed clips. The angle seam may be completed in a range of materials including Copper, Zinc, pre-painted Aluminium and pre-painted steel.

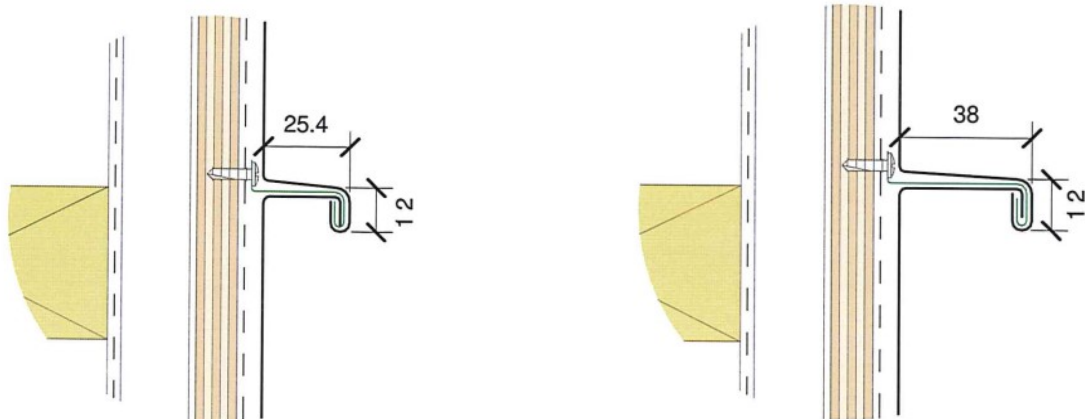

SPECIFICATION

For full specifications please refer to [Masterspec](#).

EURO CLADDING

DESIGN CONSIDERATIONS

The designer should take into account the following factors when specifying Euro Wall Angle Seam:

- Preferred profile
- Material type
- Sheet lengths
- Pan widths
- Wind loadings (refer to Wind Loadings Section)
- Reference to our detail drawings

recommendations.

- Manufactured custom cut to length subject to transport and site limitations.
- This profile is manufactured at our local branch or in cases where access or transportation is an issue can be manufactured on site.
- Sheet lengths in excess of 13meters for steel and 10 meters for other substrates, require specialized design and transportation. [Contact Metal Design Solutions Limited](#)

Euro Wall Angle Seam falls outside the of E2/AS1 and is to be designed and installed to the manufacturers

STANDARD PAN WIDTHS TO SUIT STANDARD COILS

The use of the following sizes minimizes waste and cost and generally shortens lead times. However other sizes

are available and if other than standard sizes are required [contact Metal Design Solutions](#) for more advice.

Coil Width	500mm	600mm	610mm
25mm Seam	425mm	525mm	535mm
38mm Seam	400mm	500mm	510mm

All measurements are nominal

APPROXIMATE WEIGHT

25MM SEAM HEIGHT

Roofing Material and Thickness	0.55mm Pre-Painted Steel	0.60mm Copper	0.70mm Zinc	0.90mm Aluminium
Approximate weight per m2 of visible Profile (kg)	5.23	6.08	5.92	2.88
Based on pan width of :	525mm	525mm	425mm	535mm

38MM SEAM HEIGHT

Roofing Material and Thickness	0.55mm Pre-Painted Steel	0.60mm Copper	0.70mm Zinc	0.90mm Aluminium
Approximate weight per m2 of visible Profile (kg)	5.50	6.38	6.29	3.02
Based on pan width of :	500mm	500mm	400mm	510mm

All measurements are nominal

SUBSTRATE

The plywood substrate falls outside of Metal Design Solutions scope of works and is important that it is designed and installed as a structural element of the building as the profile is installed directly to the plywood.

Reference should be made by the designer to the NZBC and to [Carter Holt Harvey Plywood Installation Guide](#). In some cases increased or decreased support spacing may be applicable depending on wind loads.

DRAINAGE, EXPANSION AND UNDERLAY

DRAINAGE

Euro Wall Angle seam requires to be installed on plywood substrate on drained cavity. For a fuller explanation of this refer to the [NZ Metal Roof and Wall Cladding Code of Practice](#).

EXPANSION

All metal cladding and flashings are subject to expansion and contraction caused by changes in temperature, and their design should allow for this movement. The expansion of cladding depends on the materials, the constraints imposed by the fixing, the heat paths in the building and the actual temperature. Linear expansions is accommodated by the use of a combination of fixed and sliding clips where necessary.

Due allowance must be made for expansion where the cladding forms a connection with any flashing.

UNDERLAY

A breather type underlay is required under wall cladding. Metal Design Solutions recommends the use of [Covertex 403](#). For a fuller explanation of this refer to the [NZ Metal Roof and Wall Cladding Code of Practice](#).

WIND LOADINGS

It is first necessary for the designer to calculate the design wind load for the wall cladding in accordance with generally acceptable practice, by reference to AS/NZS 1170:2002, and/or NZS 3604:1999. For a fuller explanation of this refer to the [NZ Metal Roof and Wall Cladding Code of Practice](#).

The uplift forces on Euro Wall Angle Seam are transferred through the building via the clips and fasteners to the substrate. The performance criteria is the number of clips or fasteners per m², which can be varied by the spacing's of the clips, or the width of the panels.

The standard option for improving the uplift resistance would be to place the clips and fasteners closer together, however, other options exist such as reducing the width of the end bays or increasing the metal thickness.

In these higher wind zones, consideration should also be given to reducing the maximum gable or verge panel width to a maximum of 400mm.

The number of concealed clips and fasteners per lineal meter and ultimately per m² can be determined using the following graph as published by the NZMRM in the [NZ Metal Roof and Wall Cladding Code of Practice](#).

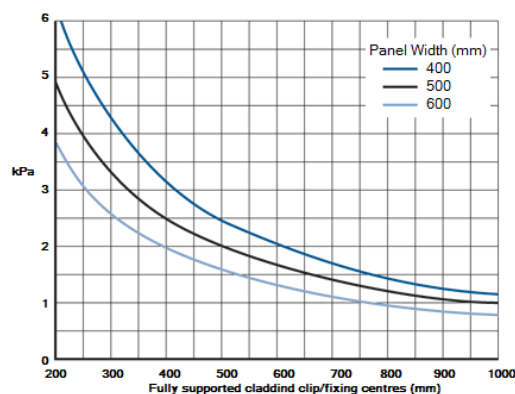

PRIMARY FIXING CHART

The Angle Seam profile should be fixed in accordance with the following chart to the plywood substrate, and into the primary structure where possible. Fixing spacing should be derived in conjunction with the Wind Load Design Graph. An indicative spacing is shown in the wind graph above. [Please contact Metal Design Solutions](#) for fixing information for specific projects.

Product	Material	Clip Material	Screw/Nail Type Approved Timber Type	Indicative Fixing Spacings 1.2kPa Wind Load to body of roof/cladding (Standard Pan widths)	
				Periphery (mm)	Remainder (mm)
Angle Seam	Steel Based	Stainless Steel	25mm Stainless Steel Full Shank Annular Grooved Flat Head Nails	400	800
	Copper	Stainless Steel	25mm Stainless Steel Full Shank Annular Grooved Flat Head Nails	400	800
	Aluminium	Stainless Steel	25mm Stainless Steel Full Shank Annular Grooved Flat Head Nails	400	800
	Zinc	Stainless Steel	25mm Stainless Steel Full Shank Annular Grooved Flat Head Nails	400	800

INSTALLATION

Installation of the profile will be undertaken by an experienced Metal Design Solutions installer with installation carried out in accordance Metal Design Solutions standard details and in compliance with the [NZ Metal Roof and Wall Cladding Code of Practice](#).

This product, if installed in accordance with the manufacturer's standard installation details, will on reasonable grounds meet the requirements of the following New Zealand Building Code clauses:

Clause B1 – Structure, Performance, B1.3.1, B1.3.2, B1.3.3(a), (b), (c), (f), (g) + (h)

Clause B2 – Durability, Performance, B2.3.1 (b), B2.3.2

Clause C3 – Fire, Performance C3.7(a)

MAINTENANCE

Regular maintenance is required to maximize the lifespan of this profile and components.

Full maintenance guides are available for selected material below:

- Pre-painted steel - [ColorSteel](#)
- Pre-painted aluminium - [ColorCote](#)
- Euramax - [Ambro Metals](#)
- Copper - [Aurubis](#)
- Zinc - [VM Zinc](#)

WARRANTY

Residential warranties are available for pre-painted steel and aluminium products from ColorSteel or ColorCote.

Refer to the manufacturer's brochures for product selection, limitation's and restrictions, based on the specific projects site Environmental Category and product use location as warranty periods are determined by where the material is used and its location.

Product maintenance requirements also impact warranty periods, refer to the manufacturers product recommendations, maintenance requirements and product usage restrictions for expected warranty durations.

Product warranties and material selection are available on request for specific projects.

Metal Design Solutions warranty period is 10 years from the date of Practical Completion of the Contract Works for installation and workmanship.

CONTACT

For technical assistance please contact Metal Design Solutions:

Physical Address: 54 Rangī Road, Takanini

Telephone: 09 640 0009

Email: info@mds.net.nz

Website: www.mds.net.nz

Name:

Richard Caminada

Position:

**Director and Master Craftsman - EID. DIPL.
Spenglermeister**

Signed on behalf of Metal Design Solutions: