

TRU-CLOSE HEAVY DUTY HINGES ON PED GATE
1:4

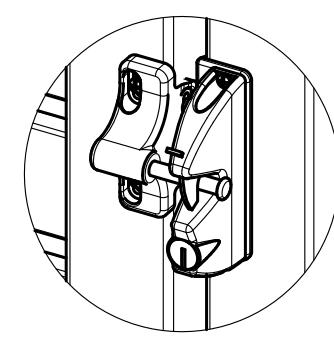

LOKKLATCH ON PED GATE
1:4

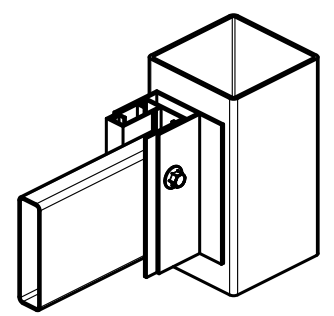

FRESNO PANEL TO POST DETAIL
1:4

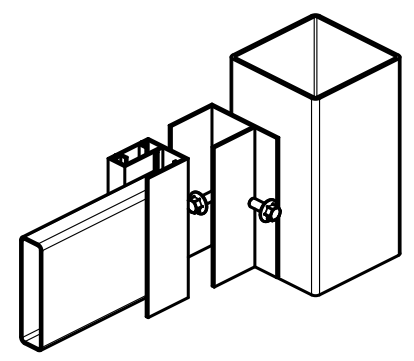

FRESNO PANEL TO POST DETAIL
1:4

PANEL CODE	DESCRIPTION	BRACKET CODE	HEIGHT	WIDTH	PANEL RAKE	HORIZONTALS	VERTICALS	TUBE SPACINGS
UFSLAT1820	FRESNO FENCE PANEL	N/A	1765	2000	N/A	65X16X1.3 RHS	30X30 CHANNEL	20 (85 CENTRES)
SGSL/1810	FRESNO PEDESTRIAN GATE	N/A	1765	1000	N/A	65X16X1.3 RHS	30X30 CHANNEL	20 (85 CENTRES)



SIZE:	A3	SCALE:	1:25
DRAWING NO:	FRE18 - SS	REVISION:	01
DATE ISSUED:	2023-04-20	SHEET:	1 OF 2

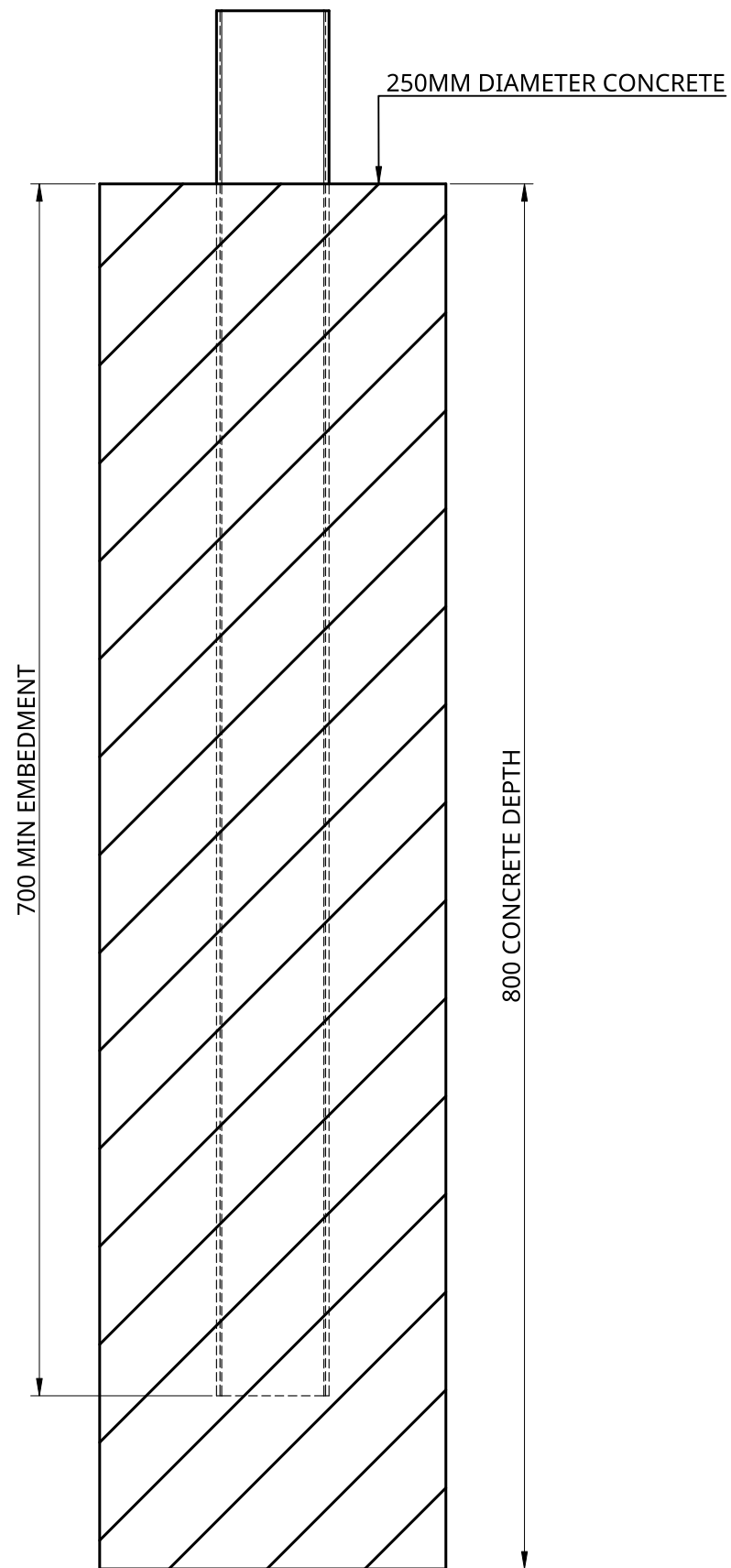

IN GROUND POST CONNECTION

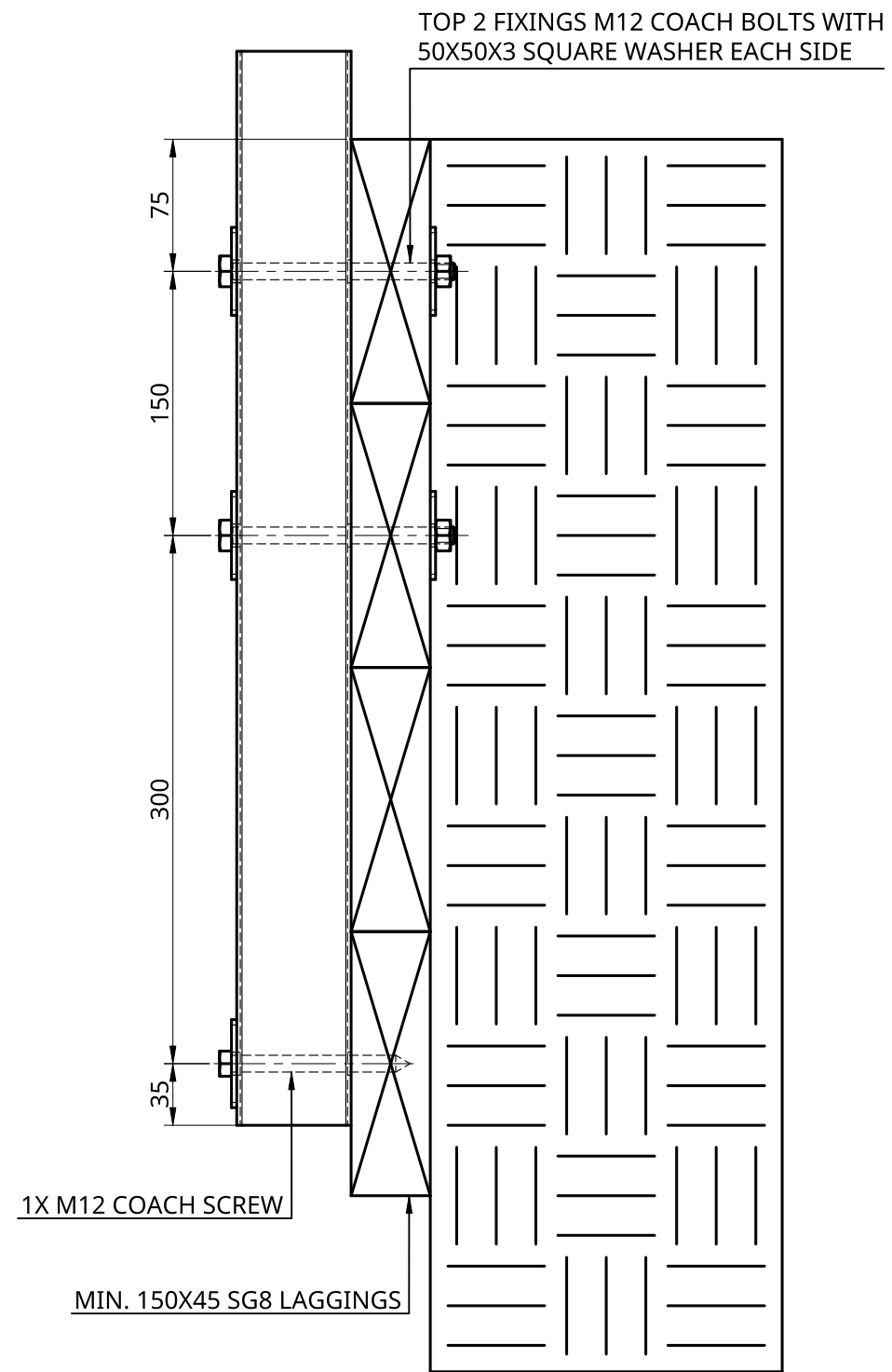

SIDE FIX TO TIMBER RETAINING WALL CONNECTION

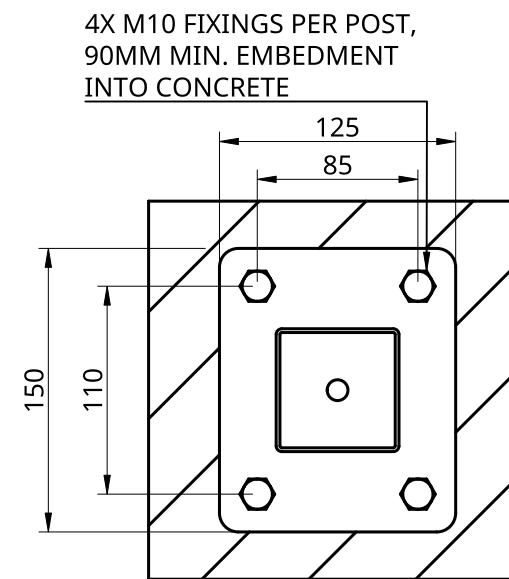

BASEPLATED POST CONNECTION

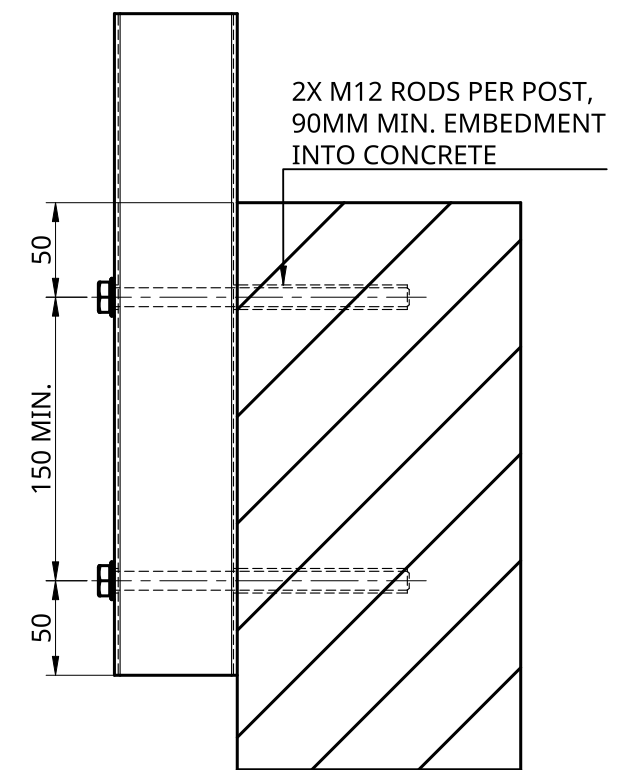

SIDE FIX TO CONCRETE CONNECTION



SIZE:	A3	SCALE:	1:4
DRAWING NO:	FRE18 - SS	REVISION:	01
DATE ISSUED:	2023-04-20	SHEET:	2 OF 2