

ClearSpan F150 Bar Assembly

Part No.

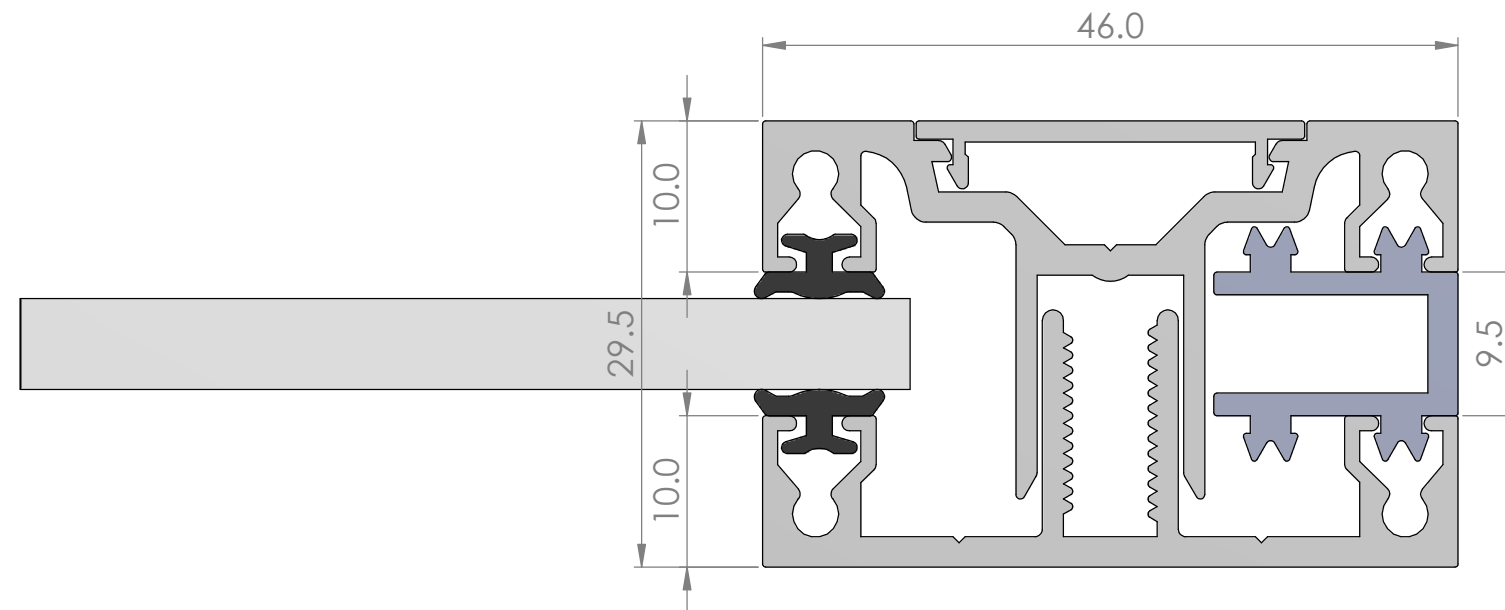

UGS
 PO Box 84 262,
 Westgate, Auckland
 0657 New Zealand
 Phone: +64 9 838 6429
 www.ugs.co.nz

Description and Notes:
 ClearSpan F150 Bar Assembly

Material:

Vendor:

Weight (Kg):

Design by: Peter Herrick

Date: 4/28/2022

Drawn by: G.Termeh

Sheet: 2 of 2

Finish:

Vendor Ref:

Area (m2):

Units: Metric (mm & Kg)

Drawing No.

Rev:

Scale: N/A