

# Outdoor Accents

## Material

Carbon Steel 2mm-2.7mm thick

## Finish

Double-Barrier Coating



Quik Guard® Coating: Hex-Head Washer



Size: See illustration on the right and tables below

## Features & Benefits

- Flat T and L strap ties, Bolt-like connectors bring decorative appeal and lateral strength to your outdoor living area or even an indoor project
- Fastener and washer create decorative bolt-like connections but install with the ease of a screw and without predrilling
- Post bases secure timber posts to concrete, while providing a 25mm standoff height to help prevent rot from standing water and ground moisture
- All hardware has been structural strength tested and approved, and can be used to resist wind or seismic loads
- Black Double-Barrier Coating offers premium look while providing a medium level of corrosion protection for many outdoor applications
- Patent hex-head washer design facilitates easy installation

## Installation

- Use all specified fasteners

## Approvals

- IAPMO-UES ER-192
- IAPMO-UES ER-280
- FL13975-R5
- FL10865-R4

## Construction Details

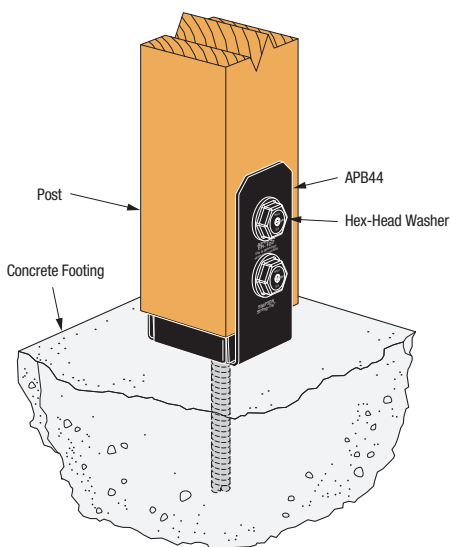

APB44 Post Base Installation

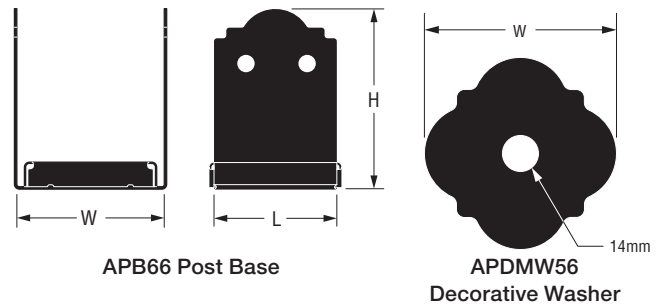

APB66 Post Base

APDMW56 Decorative Washer

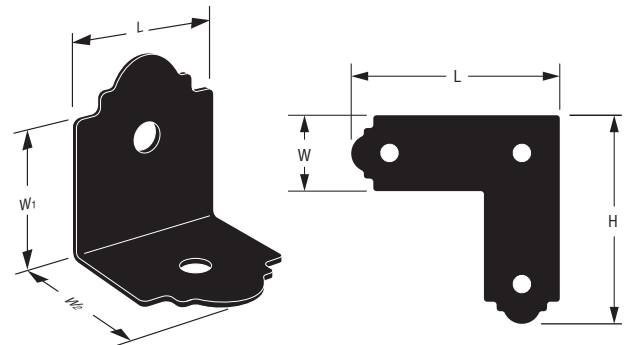

APA4 Heavy Angle

APL4 Strap Tie

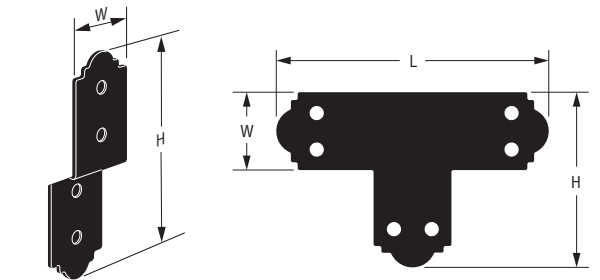

APDJT Deck Joist Tie

APT6 Strap Tie

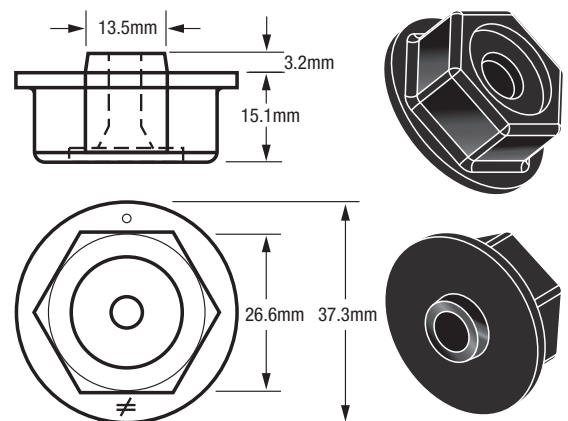

STN22 Hex-Head Washer

# Outdoor Accents

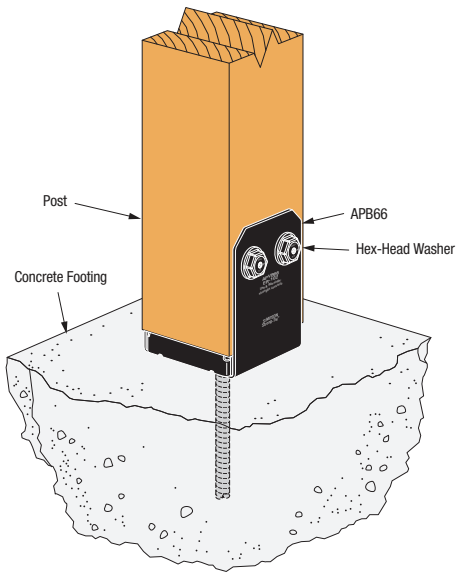

**APB66 Post Base Installation**

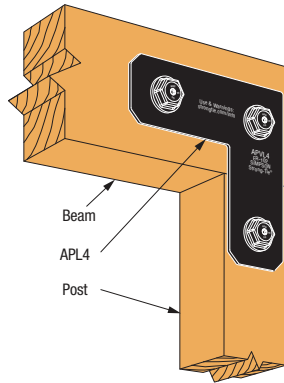

**APL4 Post-to-Beam Corner Installation**

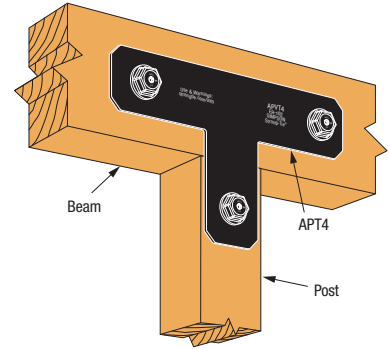

**APT4 Post-to-Beam Corner Installation**

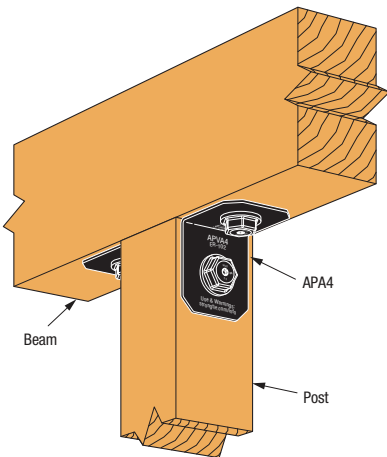

**APA Post-to-Beam Corner Installation**

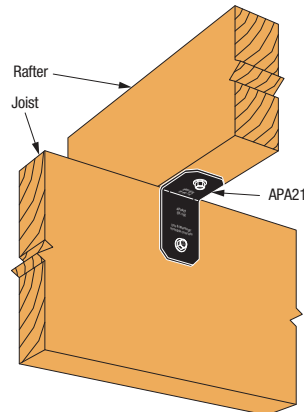

**APA21 Joist-to-Rafter Installation**

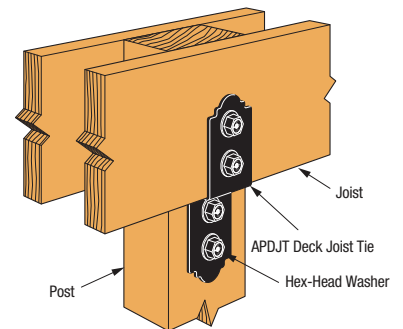

**APDJT Joist-to-Post Connection**

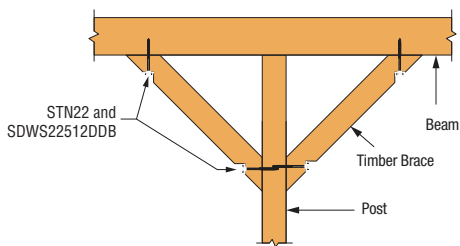

**STN22 & SDWS Timber Brace**

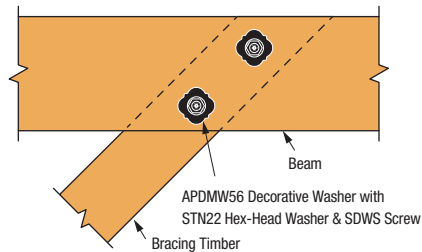

**STN22 & SDWS Timber Brace Connection with Beam**

# Outdoor Accents

## Technical Data - Post Bases

Model No.	Dimensions (mm)			Fasteners Qty		Design Capacity (kN)				Box Qty
	L	W	H	Column	Anchor Dia. (mm)	Australia		New Zealand		
						Uplift ( $k_1=1.14$ )	Download ( $k_1=0.69$ )	Uplift ( $k_1=1.0$ )	Download ( $k_1=0.8$ )	
APB44	76	90	178	4	16	4.4	38.2	4.4	31.5	8
APB66	127	140	191	4	16	5.0	62.9	2.5	51.8	6

- Design Capacity is the lesser of (1) the Characteristic Capacity multiplied by the Australian Capacity Factor, or the NZ Strength Reduction Factor ( $\phi$ ), and applicable the k modification factors following AS 1720.1 and NZS 3603 and (2) the Serviceability Capacity which is the load at 3.2mm joint slip. Design Capacity is the minimum of test data and structural joint calculation.
- For Australia, the Capacity Factor ( $\phi$ ) is 0.85 for nails and screws for structural joints in a Category 1 application. Reduce tabulated values where other Category applications govern. For NZ, the Strength Reduction Factor ( $\phi$ ) is 0.80 for nails and screws in lateral loading.
- Duration of Load Factor ( $k_1$ ) is as shown. Reduce Duration of Load Factor where applicable. Capacities may not be increased.
- Timber species for joint design is seasoned Radiata Pine, which is Australia

- Joint Group JD4 per AS 1720.1 Table H2.4 and New Zealand timber grade SG8.
- Uplift loads have been increased for wind or earthquake or seismic with no further increase allowed; reduce where others govern.
- Downloads may not be increased for short-term loading.
- Specifier to design concrete for uplift capacity.
- Downloads shall be reduced where limited by capacity of the post.
- All post fasteners are a Simpson Strong-Tie® SDWS22312DB inserted through an STN22 washer.
- Post bases do not provide adequate resistance to prevent members from rotating about the base and therefore are not recommended for non-top-supported installations (such as fences or unbraced carports).

## Technical Data - Deck Joist Tie

Model No.	Ga.	Dimensions (mm)			Design Capacity (kN) - Download		Box Qty
		S	W	H	Australia	New Zealand	
					Floor ( $k_1=0.69$ )	Floor ( $k_1=0.8$ )	
APDJT1.75-4	10	45	76	246	14.4	13.5	24

- Design Capacity is the lesser of (1) the Characteristic Capacity multiplied by the Australian Capacity Factor, or the NZ Strength Reduction Factor ( $\phi$ ), and applicable the k modification factors following AS 1720.1 and NZS 3603 and (2) the Serviceability Capacity which is the load at 3.2mm joint slip. Design Capacity is the minimum of test data and structural joint calculation.
- For Australia, the Capacity Factor ( $\phi$ ) is 0.85 for nails and screws for structural joints in a Category 1 application. Reduce tabulated values where other Category applications govern. For NZ, the Strength Reduction Factor ( $\phi$ ) is 0.80 for nails and screws in lateral loading.
- Duration of Load Factor ( $k_1$ ) is as shown. Reduce Duration of Load Factor

- where applicable. Capacities may not be increased.
- Timber species for joint design is seasoned Radiata Pine, which is Australia Joint Group JD4 per AS 1720.1 Table H2.4 and New Zealand timber grade SG8.
- Design capacity is for a single part.
- Joist fastener is a Simpson Strong-Tie SDWS22512DB inserted through an STN22 washer.
- Post fastener is a Simpson Strong-Tie SDWS22312DB inserted through an STN22 washer.

## Technical Data - Strap Ties

Model No.	Dimensions (mm)			Fasteners Qty		Design Capacity (kN)				Box Qty
	W	L	H	Column	Beam	Australia		New Zealand		
						Uplift ( $k_1=1.14$ )	$F_1$ ( $k_1=1.14$ )	Uplift ( $k_1=1.0$ )	$F_1$ ( $k_1=1.0$ )	
APL4	76	210	210	2	4	5.7	3.0	5.7	3.0	8
APL6	127	286	286	4	6	8.6	6.0	8.6	6.0	
APT4	76	343	210	2	4	5.9	4.5	5.9	4.5	
APT6	127	445	286	4	8	12.9	6.3	10.8	6.3	

- Design Capacity is the lesser of (1) the Characteristic Capacity multiplied by the Australian Capacity Factor, or the NZ Strength Reduction Factor ( $\phi$ ), and applicable the k modification factors following AS 1720.1 and NZS 3603 and (2) the Serviceability Capacity which is the load at 3.2mm joint slip. Design Capacity is the minimum of test data and structural joint calculation.
- For Australia, the Capacity Factor ( $\phi$ ) is 0.85 for nails and screws for structural joints in a Category 1 application. Reduce tabulated values where other Category applications govern. For NZ, the Strength Reduction Factor ( $\phi$ ) is 0.80 for nails and screws in lateral loading.
- Duration of Load Factor ( $k_1$ ) is as shown. Reduce Duration of Load Factor

- where applicable. Capacities may not be increased.
- Timber species for joint design is seasoned Radiata Pine, which is Australia Joint Group JD4 per AS 1720.1 Table H2.4 and New Zealand timber grade SG8.
- Allowable loads have been increased for wind or seismic loads with no further increase allowed.
- Connectors must be installed in pairs. Allowable loads do not apply to single parts.
- All fasteners are a Simpson Strong-Tie® SDWS22312DB inserted through an STN22 washer.

# Outdoor Accents

## Technical Data - Angles (2 required for APA4)

Model No.	Dimensions (mm)			Fasteners Qty		Design Capacity (kN)				Box Qty
	L	W <sub>1</sub>	W <sub>2</sub>	Column (Qty)	Beam (Qty)	Australia		New Zealand		
						Uplift (k <sub>i</sub> =1.14)	F <sub>i</sub> (k <sub>i</sub> =1.14)	Uplift (k <sub>i</sub> =1.0)	F <sub>i</sub> (k <sub>i</sub> =1.0)	
APA4	76	83	76	2	2	2.0	6.2	2.0	6.2	12
APA21	35	51	38	1	1	0.9	1.1	0.9	1.1	90

- Design Capacity is the lesser of (1) the Characteristic Capacity multiplied by the Australian Capacity Factor, or the NZ Strength Reduction Factor ( $\phi$ ), and applicable the k modification factors following AS 1720.1 and NZS 3603 and (2) the Serviceability Capacity which is the load at 3.2mm joint slip. Design Capacity is the minimum of test data and structural joint calculation.
- For Australia, the Capacity Factor ( $\phi$ ) is 0.85 for nails and screws for structural joints in a Category 1 application. Reduce tabulated values where other Category applications govern. For NZ, the Strength Reduction Factor ( $\phi$ ) is 0.80 for nails and screws in lateral loading.
- Duration of Load Factor (k<sub>1</sub>) is as shown. Reduce Duration of Load Factor where applicable. Capacities may not be increased.
- Timber species for joint design is seasoned Radiata Pine, which is Australia Joint Group JD4 per AS 1720.1 Table H2.4 and New Zealand timber grade SG8.
- Allowable loads have been increased for wind or seismic loads with no further increase allowed.
- For APA4, connectors must be installed in pairs. Allowable loads do not apply to single parts.
- For APA21 - Allowable loads are for a single part.
- All fasteners for APA4 are a Simpson Strong-Tie® SDWS22312DB inserted through an STN22 washer.
- All fasteners for APA21 are a Simpson Strong-Tie® SD#10x38.

## Technical Data - Decorative Washer

Model No.	Thickness	Hole Dia.	W
APDMW56	2.7 mm	15 mm	76 mm

- Fastener is SDWS22312DBB or SDWS22512DBB, inserted through an STN22 washer.

## Technical Data - Connector Screws

Model No.	Size	Thread Length (mm)	Timber Side Member (mm)	Characteristic Withdrawal Value (N/mm)				Box Qty
				Australia		New Zealand		
				JD4	JD5	SG8	SG6	
SD10112DBB	#10 x 38mm	25	38	101	71	139	97	5 Packs (50 per clamshell)

- Characteristic values are for connections between two members with full thread penetration into the main member.
- Characteristic values are based on installation into the side grain of the timber with the screw axis perpendicular to the face of the member.
- The main and side members shall be sawn timber or structural composite timber with the specific gravity or equivalent specific gravity typical of JD4 and JD5 for Australia or SG8 and SG6 for New Zealand.
- For design values, apply appropriate capacity factor.
- Design values shall be multiplied by applicable adjustment factors from AS 1720.1 or NZS 3603.

## Technical Data - Structural Timber Screw and Hex-Head Washer

Model No.	Hex-Head Washer	Screw Length (mm)	Thread Length (mm)	Timber Side Member (mm)	Characteristic Lateral Value, Q <sub>kl</sub> (N)					Carton Qty
					Australia			New Zealand		
					JD4	JD5	JD6	SG8	SG6	
SDWS22312DBBRC12	STN22-R8	89	51	38	3475	2840	2660	3460	3145	10 Packs (12 per clamshell)
SDWS22312DBB-R50										6 Packs (50 per box)
SDWS22512DBBRC12		140	70		6930	6400	3910	9140	8580	10 Packs (12 per clamshell)

- Characteristic values are for connections between two members with full thread penetration into the main member.
- Characteristic values are based on installation into the side grain of the timber with the screw axis perpendicular to the face of the member.
- The main and side members shall be sawn timber or structural composite timber with the specific gravity or equivalent specific gravity typical of JD4, JD5 and JD6 for Australia or SG8 and SG6 for New Zealand.
- For design values, apply appropriate capacity factor.
- Design values shall be multiplied by applicable adjustment factors from AS 1720.1 or NZS 3603.