

Together we're  
building safer, stronger  
structures.



## Strong-Rod™ Systems



SEISMIC AND WIND RESTRAINT SYSTEMS GUIDE



AUSTRALIA  
**1300 STRONGTIE**  
(1300 787664)  
strongtie.com.au



NEW ZEALAND  
**09 477 4440**  
strongtie.co.nz



# Smart design from product to project



# Product Design

We put our product designs through rigorous testing at our cutting-edge research and development facilities in order to deliver best-in-class structural solutions to the market. Our high-performance Strong-Rod™ systems secure mid-rise, timber-framed buildings against forces caused by seismic and wind events. With innovative components that work together to create a continuous load path, Simpson Strong-Tie rod systems are built for maximum resilience and installation efficiency.

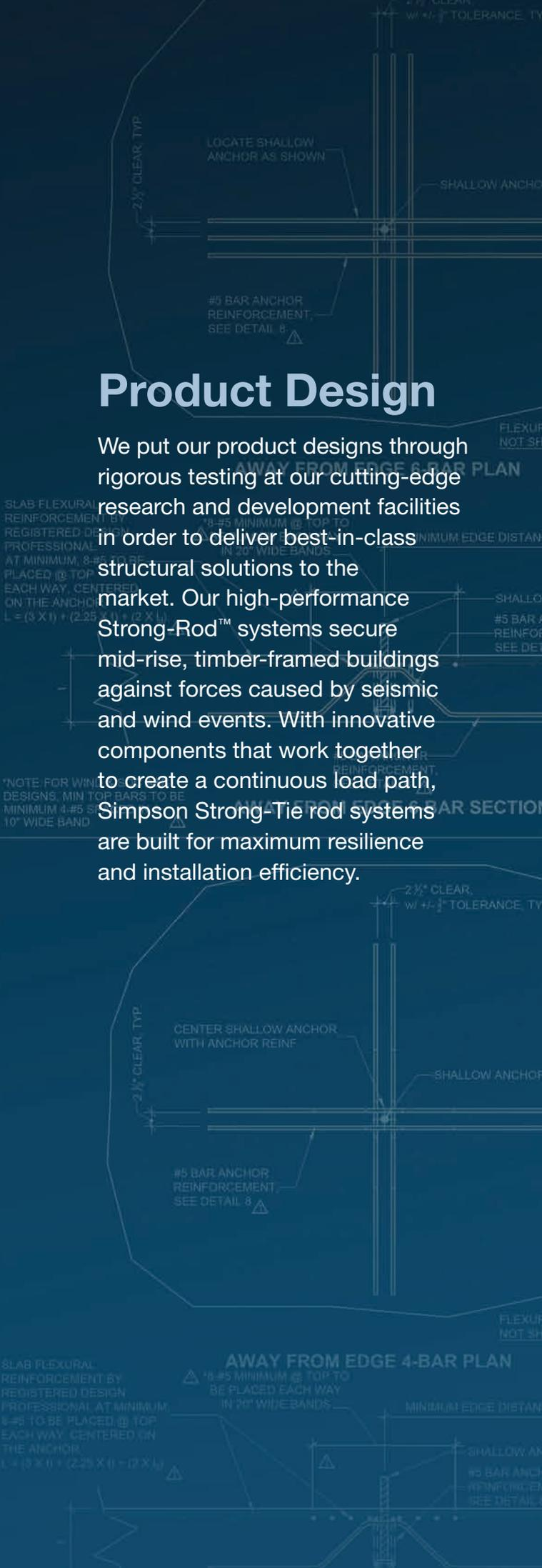

## Company Profile

Simpson Strong-Tie Company Inc. was founded in Oakland, California, and has been manufacturing timber-to-timber and timber-to-concrete connectors since 1956. Since then, Simpson Strong-Tie has grown to be the world's largest manufacturer of construction connectors. In recent years, the company's growth has included expanding its product offering to include prefabricated shearwalls, anchor systems for concrete and masonry, collated fastening systems and repair, protection and strengthening systems for concrete and masonry.

### Simpson Strong-Tie Company Inc. services include

- Quality products value-engineered for the lowest installed cost at the highest-rated performance levels
- Most thoroughly tested and evaluated products in the industry
- Strategically located warehouse facilities
- Nationwide field engineering support
- National sales team
- In-house R&D and tool and die professionals
- In-house product testing and quality control engineers

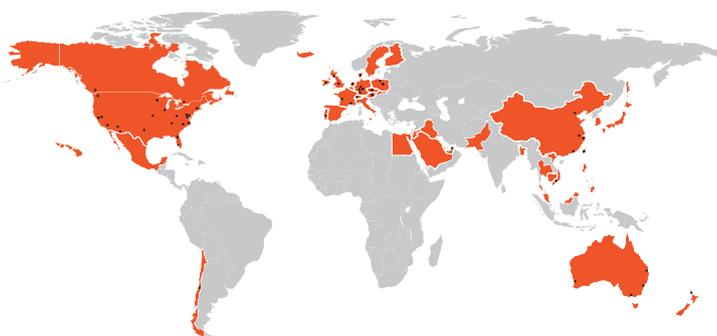

● Factories, offices, and warehouses in Australia, Austria, Canada, Chile, China, Czech Republic, Denmark, France, Germany, Netherlands, New Zealand, Poland, Portugal, Switzerland, Taiwan, UK and U.S.A.

■ Distribution in Australia, Canada, Chile, Western Europe, part of Eastern Europe, Middle East, Japan, Korea, Egypt, China, Taiwan & other Asian countries, Mexico, New Zealand, UK and U.S.A.

## The Simpson Strong-Tie Quality Policy

We help people build safer structures economically. We do this by designing, engineering and manufacturing "No Equal" structural connectors and other related products that meet or exceed our customers' needs and expectations. Everyone is responsible for product quality and is committed to ensuring the effectiveness of the Quality Management System.

Karen Colonias  
Chief Executive Officer

## Getting Fast Technical Support

When you call for engineering technical support, we can help you quickly if you have the following information at hand.

- Which Simpson Strong-Tie literature piece are you using? (See the back cover for the form number.)
- Which Simpson Strong-Tie product or system are you inquiring about?
- What is your load requirement?

## We Are ISO 9001-2008 Registered

Simpson Strong-Tie is an ISO 9001-2008 registered company. ISO 9001-2008 is an internationally-recognised quality assurance system that lets our domestic and international customers know they can count on the consistent quality of Simpson Strong-Tie® products and services.



# Table of Contents

Important Information and General Notes..... 6-7

Why Continuous Rod Tiedown Systems?..... 8-9

Strong-Rod™ ATS Anchor Tiedown System for Shearwall Overturning Restraint..... 10-11

    What is the Load Path? ..... 12

    Key Considerations for Designing an Anchor Tiedown System for Shearwall Overturning Restraint .... 13-17

Strong-Rod™ ATS Components ..... 18, 21-26

Strong-Rod™ ATS Run Termination Details ..... 19-20

Strong-Rod™ ATS Run Start Details ..... 27-28

Strong-Rod™ ATS Design Considerations ..... 29

Anchor Tiedown System Design Example ..... 30-33

Specifying Rod Systems for Shearwall Overturning Restraint..... 34

## Product Identification Key

Products and additional information are divided into four general categories, identified by tabs along the page's outer edge.

**General information**

**6-9 ▶**

**Strong-Rod ATS  
(Anchor Tiedown Systems)**

**10-17 ▶**

**Strong-Rod ATS Components**

**18-28 ▶**

**Strong-Rod ATS Design**

**29-34 ▶**



## Let Simpson Strong-Tie Help Design Your System.

Here's how to reach us

<b>Australia</b>	<b>New Zealand</b>
Call <b>1300 STRONGTIE</b> (1300 787664)	Call 09 477 4440
<b>strongtie.com.au</b>	<b>strongtie.co.nz</b>

## Important Information and General Notes

### Strong-Rod™ Systems Assemblies

1. Simpson Strong-Tie reserves the right to change specifications, designs, and models without notice or liability for such changes.
2. Steel used for each Simpson Strong-Tie® product is individually selected based on the product's steel specifications, including strength, thickness, formability, finish and ability to weld. Contact Simpson Strong-Tie for steel information on specific products.
3. Unless otherwise noted, dimensions are in millimetres, loads are in kilonewtons.
4. Timber shrinks and expands as it loses and gains moisture content, particularly perpendicular to its grain. Take timber shrinkage into account when designing and installing connections. The effects of timber shrinkage are increased in multiple timber connections, such as floor-to-floor installations. This may result in the nuts for the vertical rod system becoming loose, requiring tightening (unless shrinkage compensating devices are installed). Timber structures supporting more than two floors and a roof should be analysed for the effects of timber shrinkage.
5. The term "Designer" used throughout this guide is intended to mean a qualified licensed professional engineer or a qualified licensed architect.
6. All connected members and related elements shall be designed by the Designer.
7. Where multiple members of timber are intended to act as one unit, they must be fastened together to resist the applied load. This design must be determined by the Designer.
8. Local and/or regional building codes may require meeting special conditions, such as rod elongation limits. Also, building codes often require special inspection of anchors installed in concrete and masonry. For compliance with these requirements, it is necessary to contact the local and/or regional building authority. Except where mandated by code, Simpson Strong-Tie products do not require special inspection.
9. All installations should be designed in accordance with the published load values.
10. The Designer is responsible for verifying that all design loads do not exceed the loads listed for each component in the restraint system.
11. Corrosion information may be found at [strongtie.com/corrosion](http://strongtie.com/corrosion).
12. Components should be kept dry and away from corrosive materials and away from steel that has already shown signs of corrosion.
13. Once installed, take precautions to prevent the RTUD from getting wet and freezing. Permanent damage may result if the installed device freezes when it has water inside it.

### General Notes for Shearwall Overturning Restraint

1. When designing for shearwall overturning restraint, the Designer is responsible for verifying that the building drift is within the acceptable code limitations. Serviceability should also be considered.
2. Studs, posts and blocking details shall be specified by the Designer and are not provided by Simpson Strong-Tie.
3. Anchorage solutions shall be specified by the Designer. Foundation size and reinforcement shall be specified by the Designer. Contact Simpson Strong-Tie to coordinate connecting components at the first level.
4. The Simpson Strong-Tie Strong-Rod Anchor Tiedown System for shearwall overturning restraint (Strong-Rod ATS) is designed to be installed floor-by-floor as the structure is built. Installation in this manner, with shearwalls, will provide lateral stability during construction.
5. Do not specify welding of products listed in this design guide unless this publication specifically identifies a product as acceptable for welding, or unless specific approval for welding is provided in writing by Simpson Strong-Tie. Cracked steel due to unapproved welding must be replaced.
6. Simpson Strong-Tie strongly recommends the following addition to construction drawings and specifications: "Simpson Strong-Tie connectors and tiedown components are specifically designed to meet the structural loads specified on the plans or provided by the Designer. Before substituting an alternate rod system, confirm load capacity and system displacement (rod elongation and shrinkage compensation device displacement) are based on reliable published testing data and/or calculations. The Designer should evaluate and give written approval for substitution prior to installation."
7. Local and/or regional building codes may have additional requirements. Building codes often require special inspection of anchors installed in concrete and masonry. For compliance with these requirements, it is necessary to contact the local and/or regional building authority.
8. Steel bearing plates shall be sized for proper length, width and thickness based on steel bending capacity and timber bearing. Deflection of bearing compression (up to 1 mm) must be included in overall shearwall deflection calculations.
9. Available Strong-Rods, fully threaded rod sizes and material grades are listed at [strongtie.com/srs](http://strongtie.com/srs).

# Important Information and General Notes

## Limited Warranty

Simpson Strong-Tie Company Inc. warrants catalogue products to be free from defects in material or manufacturing. Simpson Strong-Tie Company Inc. products are further warranted for adequacy of design when used in accordance with design limits in this catalogue and when properly specified, installed and maintained. This warranty does not apply to uses not in compliance with specific applications and installations set forth in this catalogue, or to non-catalogue or modified products, or to deterioration due to environmental conditions.

Simpson Strong-Tie® connectors are designed to enable structures to resist the movement, stress and loading that results from events such as earthquakes and high-velocity winds. Other Simpson Strong-Tie products are designed to the load capacities and uses listed in this catalogue. Properly-installed Simpson Strong-Tie products will perform in accordance with the specifications set forth in the applicable Simpson Strong-Tie catalogue. Additional performance limitations for specific products may be listed on the applicable catalogue pages.

Due to the particular characteristics of potential seismic and high wind events, the specific design and location of

the structure, the building materials used, the quality of construction, and the condition of the soils involved, damage may nonetheless result to a structure and its contents even if the loads resulting from the seismic or high wind event do not exceed Simpson Strong-Tie catalogue specifications and Simpson Strong-Tie connectors are properly installed in accordance with applicable building codes.

All warranty obligations of Simpson Strong-Tie Company Inc. shall be limited, at the discretion of Simpson Strong-Tie Company Inc., to repair or replacement of the defective part. These remedies shall constitute Simpson Strong-Tie Company Inc.'s sole obligation and sole remedy of purchaser under this warranty. In no event will Simpson Strong-Tie Company Inc. be responsible for incidental, consequential, or special loss or damage, however caused.

This warranty is expressly in lieu of all other warranties, expressed or implied, including warranties of merchantability or fitness for a particular purpose, all such other warranties being hereby expressly excluded. This warranty may change periodically — consult our website [strongtie.com](http://strongtie.com) for current information.

## Terms and Conditions of Sale

### Product Use

Products in this guide are designed and manufactured for the specific purposes shown, and should not be used with other connectors not approved by a qualified Designer. Modifications to products or changes in installations should only be made by a qualified Designer. The performance of such modified products or altered installations is the sole responsibility of the Designer.

### Indemnity

Customers or Designers modifying products or installations, or designing non-catalogue products for fabrication by Simpson Strong-Tie Company Inc. shall, regardless of specific instructions to the user, indemnify, defend and hold harmless Simpson Strong-Tie Company Inc. for any and all claimed loss or damage occasioned in whole or in part by non-catalogue or modified products.

### Non-Catalogue And Modified Products

Consult Simpson Strong-Tie Company Inc. for applications for which there is no catalogue product, or for connectors for use in hostile environments, with excessive timber shrinkage, or with abnormal loading or erection requirements.

Non-catalogue products must be designed by the customer and will be fabricated by Simpson Strong-Tie in accordance with customer specifications.

Simpson Strong-Tie cannot and does not make any representations regarding the suitability of use or load-carrying capacities of non-catalogue products. Simpson Strong-Tie provides no warranty, express or implied, on non-catalogue products. F.O.B. Shipping Point unless otherwise specified.

# Why Continuous Rod Tiedown Systems?



Seismic and wind events are serious threats to structural integrity and occupant safety. All timber-framed buildings need to be designed to resist shearwall overturning and roof-uplift forces. For one- and two-storey structures, connectors (straps, hurricane ties and holdowns) have been the traditional answer. With the growth in mid-rise, timber-framed structures, however, rod systems have become an increasingly popular lateral and uplift restraint solution.

Multi-storey structures present complicated design challenges. Frequently, the structures have larger windows and door openings, providing less space for traditional restraint systems. For all these reasons, there is increased need for restraint systems that can meet multi-storey structural demands without sacrificing installation efficiency or cost considerations.

Continuous rod tiedown systems are able to answer these demands by restraining both lateral and uplift loads, while maintaining reasonable costs on material and labour. Instead of using metal connector brackets as in a holdown system, continuous rod tiedown systems consist of a combination of rods, coupler nuts, bearing plates and shrinkage-compensation devices. These all work together to create a continuous load path to the foundation.

To contact a Simpson Strong-Tie representative for help designing your Strong-Rod™ continuous rod tiedown solution, call in Australia 1300 STRONGTIE or in New Zealand 09 477 4440.

## Tension Forces Resisted by Continuous Rod Tiedown Systems

Continuous rod tiedown systems are used to resist two types of tension forces — shearwall-overturning forces and uplift forces on roofs.

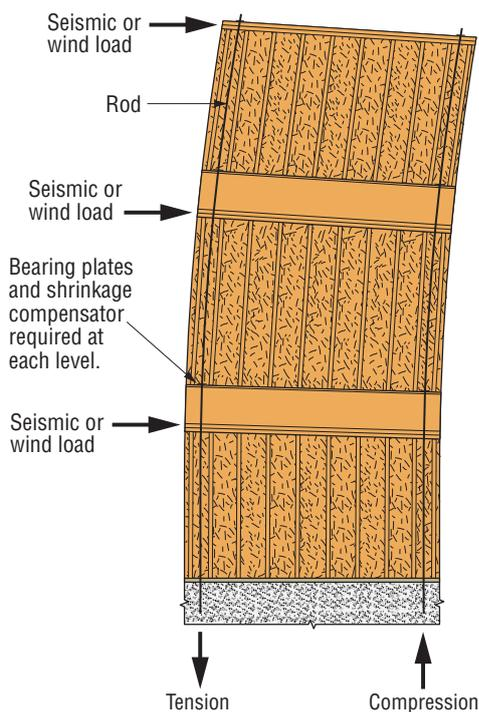

### Shearwall Overturning Restraint System

One type of tension force is a result of lateral (horizontal) forces due to a wind or seismic event. This force occurs at the end of shearwalls and its magnitude increases at lower levels as it accumulates the tension force from each level or shearwall above.

## Why Continuous Rod Tiedown Systems?

### Simpson Strong-Tie® Strong-Rod™ Systems

To ensure structural stability, a continuous rod tiedown system can be used in a mid-rise timber-framed structure to resist shearwall overturning and roof uplift.

**Strong-Rod ATS solutions** address the many factors that must be considered during design to ensure proper performance against shearwall overturning — such as rod elongation, timber shrinkage, construction settling, shrinkage compensating device deflection, incremental loads, bearing plate bending, cumulative tension loads and anchorage.

Simpson Strong-Tie Strong-Rod Systems have been extensively tested by our engineering staff at our state-of-the-art, accredited labs. Our testing and expertise have been crucial in providing customers with proven solutions.

### Leverage Our Expertise to Help with Your Rod System Designs

A large number of factors need to be considered when specifying a rod system:

- Timber shrinkage or crushing
- Fire-treated timber
- Initial and equilibrium moisture content of timber members
- Rod elongation
- Take-up device deflection
- Local code limitations

For design assistance, contact your Simpson Strong-Tie representative in Australia on 1300 STRONGTIE or in New Zealand on 09 477 4440.



# Strong-Rod™ ATS Anchor Tiedown System for Shearwall Overturning Restraint

---

To complement its research and design expertise, Simpson Strong-Tie has all the components needed to optimally design and build a continuous rod tiedown system for withstanding shearwall overturning forces. From our threaded rod to our plates and nuts, to our latest shrinkage compensators and design services, we offer Designers a complete solution.

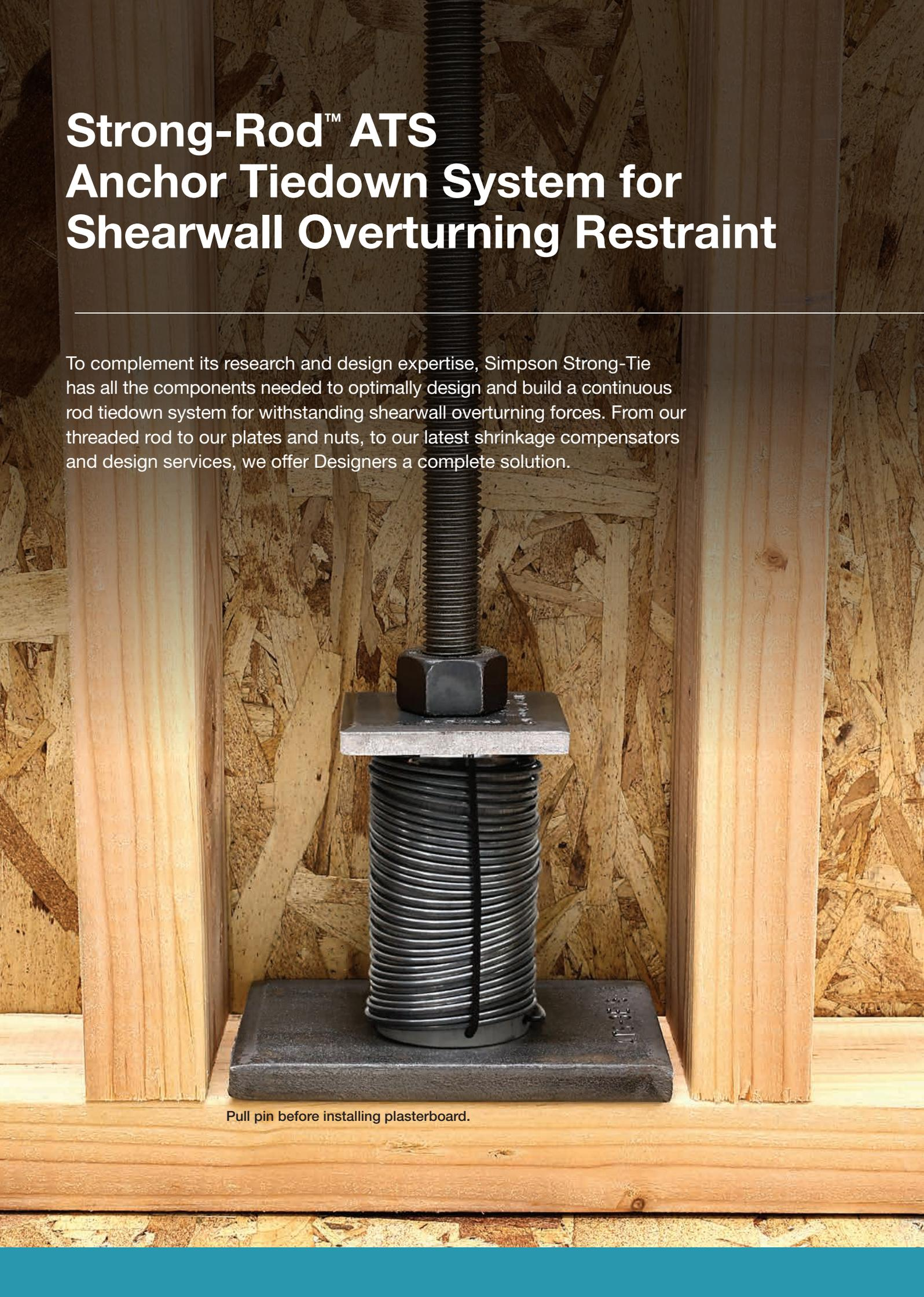

Pull pin before installing plasterboard.

## Strong-Rod™ ATS

### Anchor Tiedown System for Shearwall Overturning Restraint

A continuous load path is essential to a building's structural performance. Directing the diaphragm loads from roofs, floors and walls to the foundation in a prescribed continuous path is a widely accepted method to prevent shearwall overturning. The installation of continuous rod systems has grown in popularity with the increase in mid-rise timber (3- to 6-storey) construction. Specifying a Strong-Rod™ Anchor Tiedown System (ATS) for shearwall overturning restraint from Simpson Strong-Tie offers several advantages for Specifiers and installers alike:

- An ATS restraint provides the high load capacities required for mid-rise timber construction
- System components provide low deflection to help limit shearwall drift
- Steel tension elements of the structural lateral force resisting system
- Our knowledge of rod system performance through years of testing ensures that all system design considerations have been met

Beyond the tension and compression aspects of a continuous rod tiedown system, timber shrinkage must also be addressed. In these types of structures, shrinkage and settlement can cause a gap to develop between the steel nut and bearing plate on the timber bottom or top plate (see photo below), as the shrinkage increases cumulatively up the building and is the greatest at the uppermost floor. This can cause the system not to perform as designed and can add to system deflection. As a result, take-up devices must be used with most timber structures greater than two stories tall at each level to mitigate any gap creation and therefore ensure optimum system performance.



Rod system with no take-up device installed.



Strong-Rod ATS

# Strong-Rod™ ATS

## What is the Load Path?

### Traditional Shearwall Load Path

A traditional shearwall relies either on holdowns or straps attached to posts to transfer the net shearwall overturning forces to the foundation.

Lateral forces are transferred from the floor/roof to the plywood sheathing. The following steps describe the traditional load path:

1. Nails are typically used to transfer loads from the sheathing to the wall framing.
2. The outermost framing boundary elements transfer the tensile forces, resulting from the net overturning, to the holddown that is attached to the post at the boundary.
3. The holddown system then transfers the load in tension to an anchor that is embedded into a concrete foundation.

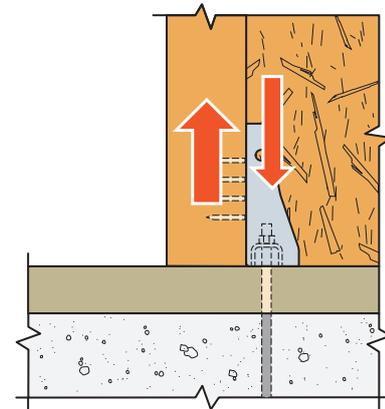

Traditional System

### Continuous Rod Tiedown System Load Path

A continuous rod tiedown system utilises a combination of threaded rods with bearing plates and take-up devices at each level to transfer the forces to the foundation. The following steps describe the continuous rod tiedown system load path:

1. The end posts deliver the sheathing load to the top plates and bearing plate.
2. Bearing plate transfers the load through a nut into the rod system.
3. Rod system transfers the load from the plate through tension in the rods to the foundation.

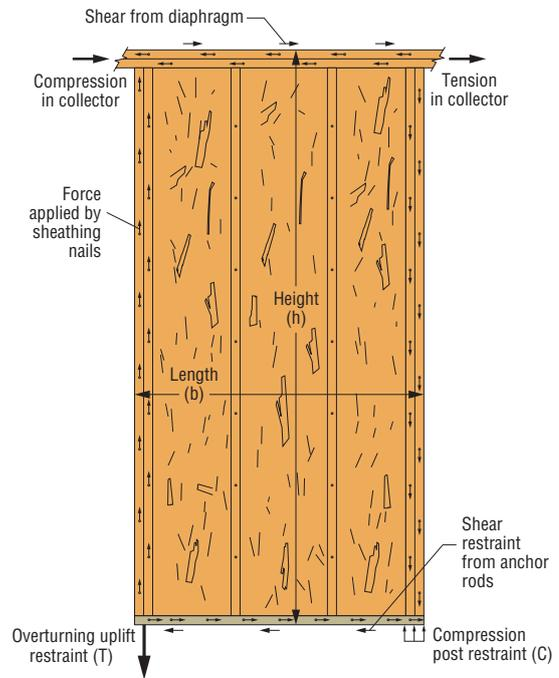

Shearwall Load Path

### Strong-Rod System Components to Achieve This Load Path

- Take-up devices (ATUD/TUD) allow for multiple rod diameters.
- Ratcheting take-up devices (RTUD) fit 1/2" (13 mm), 5/8" (16 mm) and 3/4" (19 mm) diameter rods.
- Optimised bearing plates accommodate the ATUD/TUD and RTUD sizes.
- Options for compression post configurations that standardise anchor layout and reduce non-structural timber in the upper stories.
- Shallow podium anchors provide test-proven solutions for anchoring high loads to relatively shallow podium slabs at interior and edge conditions.

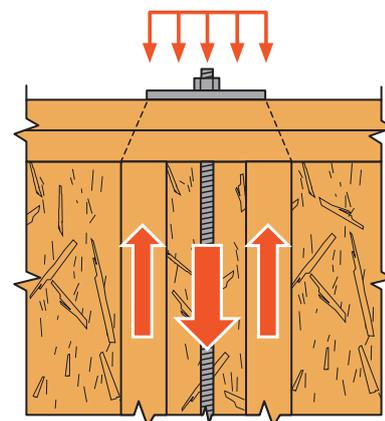

Continuous Rod Tiedown System

# Strong-Rod™ ATS

## Key Considerations for Designing an Anchor Tiedown System for Shearwall Overturning Restraint

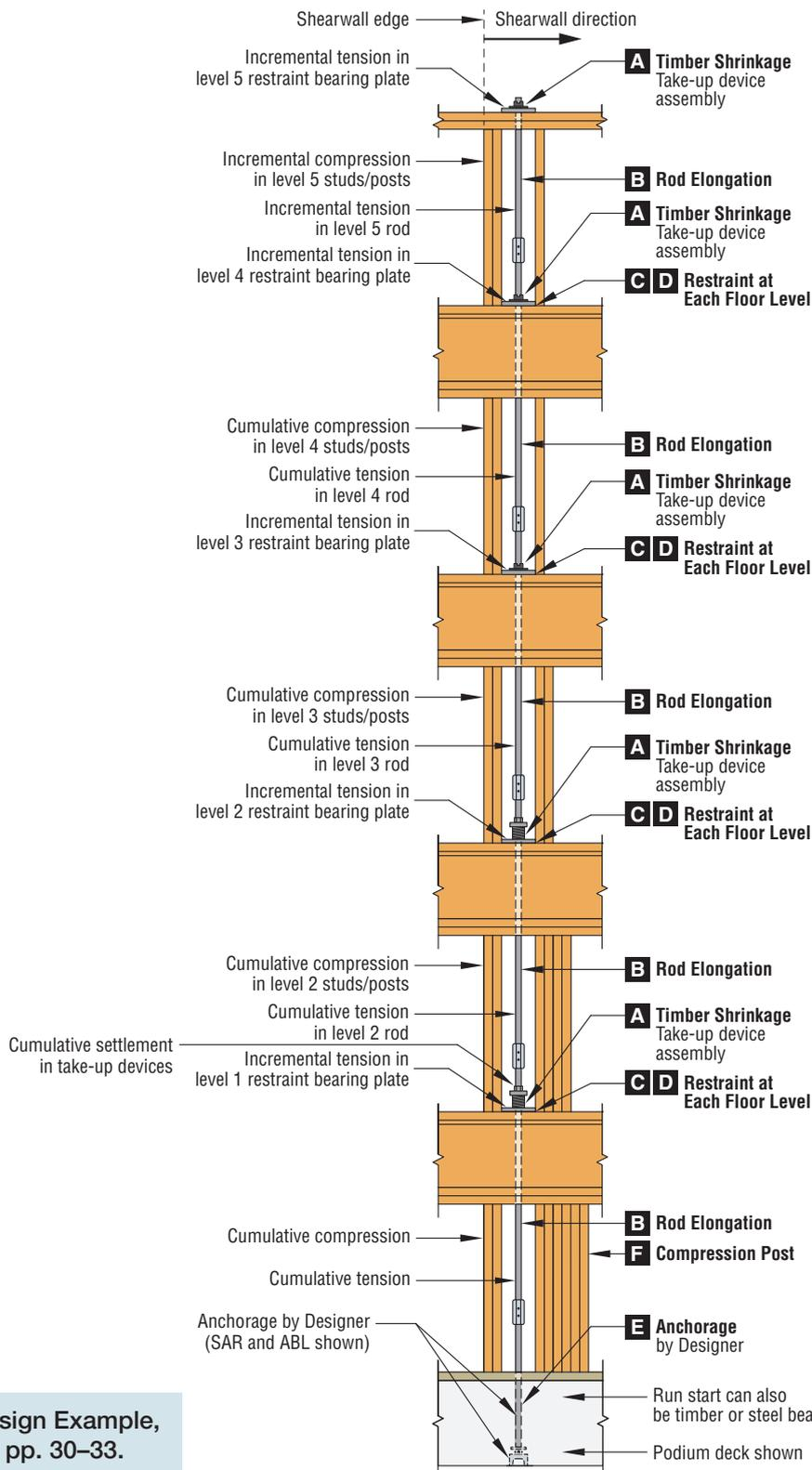

For Design Example, see pp. 30–33.

Note: The number of studs shown are illustrative only.

# Strong-Rod™ ATS

## A Timber Shrinkage

It is important to consider the effects of timber shrinkage when designing any continuous rod tiedown system. Timber studs under high compression forces, and any changes in timber moisture content, may result in axial shortening (shrinkage) but the continuous steel rod does not, which potentially forms gaps in the system.

Typically rod elongation and shrinkage compensating device are limited to a deflection of 5 mm at each level or between restraints, unless shearwall drift is determined to be within acceptable limits. Rod

diameter and take-up device choice are obviously important. Simpson Strong-Tie take-up devices (TUDs) and aluminium TUDs (ATUDs) have very little deflection ( $\Delta_A + \Delta_P$ ) and therefore minimise the contribution of device displacement to 5 mm deflection limit, which allows for smaller rod diameters.

See [strongtie.com/srs](http://strongtie.com/srs) for additional information regarding timber shrinkage and how Simpson Strong-Tie® take-up devices mitigate timber shrinkage within an Anchor Tiedown System for shearwall overturning restraint.

## B Rod Elongation

A continuous rod tiedown run will deflect under load. The amount of stretch depends on the magnitude of load, length of rod, net tensile area of steel and modulus of elasticity.

In a continuous rod tiedown system designed to restrain shearwall overturning, the rod length is defined since it is tied to the storey heights and floor depths. The modulus of steel is also a constant (200 000 MPa for steel) and steel strength does not affect elongation. The only variables then per run are the load and

rod net tensile area, which will be controlled by:

- Quantity, location and length of shearwalls provided to support the structure.
- Choice of rod diameter, which will be used in determining the rod net tensile area,  $A_e$ .

**Note: It is important to use the net tensile area,  $A_e$ , for determining rod elongation. Gross rod area,  $A_g$ , will be used for the strength calculation.**

## C Restrain Each Floor

A skipped floor system restrains two or more floors with a single restraint point to provide overturning

resistance. A continuous rod tiedown system with all floors tied-off provides overturning restraint at every floor.

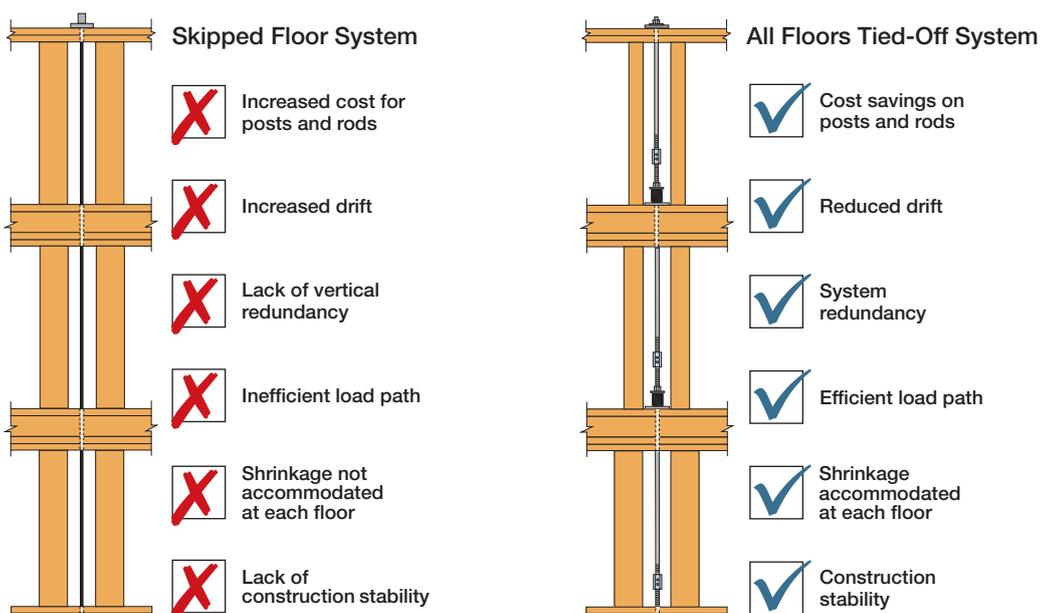

See [strongtie.com/srs](http://strongtie.com/srs) for additional information about the importance of providing restraint systems at each floor level.

# Strong-Rod™ ATS

## D Bearing Plates

Bearing plates are key components in transferring loads from the posts and top plates to the rods in an Anchor Tiedown System for shearwall overturning restraint. Bearing plates must be designed to spread the loads across the bottom plates to minimise the effects of timber crushing. Bearing plate bending must

also be checked to ensure proper steel plate thickness. These plates transfer the incremental bearing loads via compression of the bottom plates and bending of the bearing plates to a tension force in the rod. For additional information, visit [strongtie.com/srs](http://strongtie.com/srs).

## E Anchorage by Designer

Many variables affect anchorage design, such as foundation type, concrete strength, anchor embedment and edge distances. Design tools, such as the Simpson Strong-Tie® Anchor Designer™ Software, are available to help the Designer navigate the complex anchorage provisions. Anchor products, including the Pre-Assembled Anchor Bolt (PAB), are also available to simplify specification.

An elevated concrete slab over parking, commonly referred to as a podium slab, is a common anchorage/run start type for mid-rise, light-frame construction. These slabs pose a significant challenge to designers when anchoring the continuous rod tiedown system above.

In designing light-frame structures over concrete podium slabs, understand that lateral loads from the structure above will produce large tensile overturning forces whose demands often far exceed the breakout capacities of these relatively thin slabs. Simpson Strong-Tie has thoroughly researched and tested practical solutions that achieve the expected performance in order to provide Designers with additional design options. The use of the special detailing of anchor reinforcement, will greatly increase the tensile capacities of the anchors.

The concrete podium slab anchorage was a multi-year test program that commenced with grant funding from the Structural Engineers Association of Northern California and was applied toward the initial concept testing at Scientific Construction Laboratories, Inc. Following that test, a full-scale, detailed testing was completed at the Simpson Strong-Tie® Tye Gilb Laboratory. The design approach follows code calculation procedures supported by testing of adequately designed anchor reinforcement specimens. Based on the empirical test data, the inner concrete breakout cone plus the added anchor reinforcement each provided a percentage contribution to the measured peak capacity of the entire anchorage assembly. These contributions are distributed to the overall anchorage capacity and the concept is then utilised for each installation condition being considered for the calculation.

For assistance with your design, visit [strongtie.com/srs](http://strongtie.com/srs) for suggested anchorage-to-podium slab details, slab design requirements and Shallow Podium Slab Anchor Kit product information. Also visit our Structural Engineering Blog at [seblog.strongtie.com](http://seblog.strongtie.com) for more information.

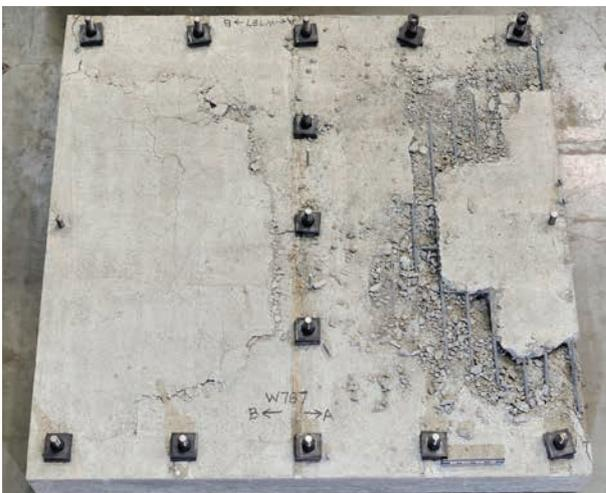

Anchor reinforcement testing at Tye Gilb Laboratory for edge and away-from-edge conditions.

# Strong-Rod™ ATS

## F Compression Posts

Compression posts play an integral role in designing a Strong-Rod Anchor Tiedown System for shearwall overturning restraint. As tension loads are resisted by the Strong-Rod ATS steel rods, adequate compression elements are crucial in the opposite

end of the shearwall. Compression posts are either single members or multiple members. A Designer may use either a symmetrical or an asymmetrical post configuration. These elements are specified by the Designer. See [strongtie.com/srs](http://strongtie.com/srs) for more information.

### Asymmetrical Posts

This arrangement means a maximum of three built-up studs at the end of the wall and multiple number of studs at the opposite side of the Strong-Rod. This provides uniform anchor placement and consistent end-of-wall placement location at upper floor levels.

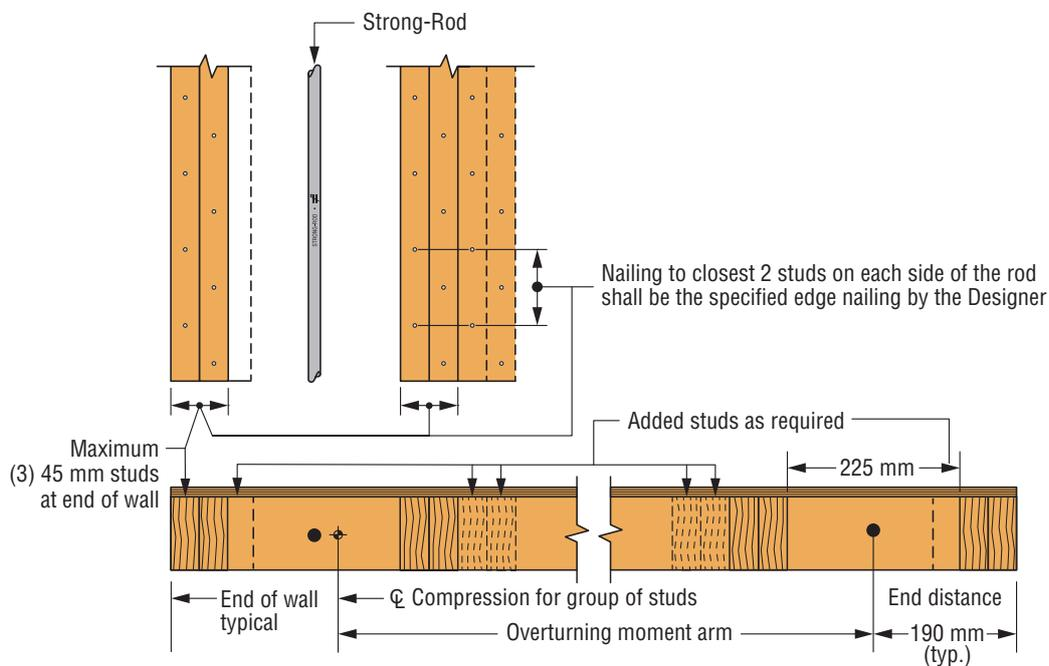

Estimate of Moment Arm = Wall Length – End Distance – Centre of Gravity of Compression End

# Strong-Rod™ ATS

## F Compression Posts (cont.)

### Symmetrical Posts

An equal number of posts or studs on each side of the Strong-Rod.  
End of the shearwall requires extra framing to maintain edge-of-wall line.

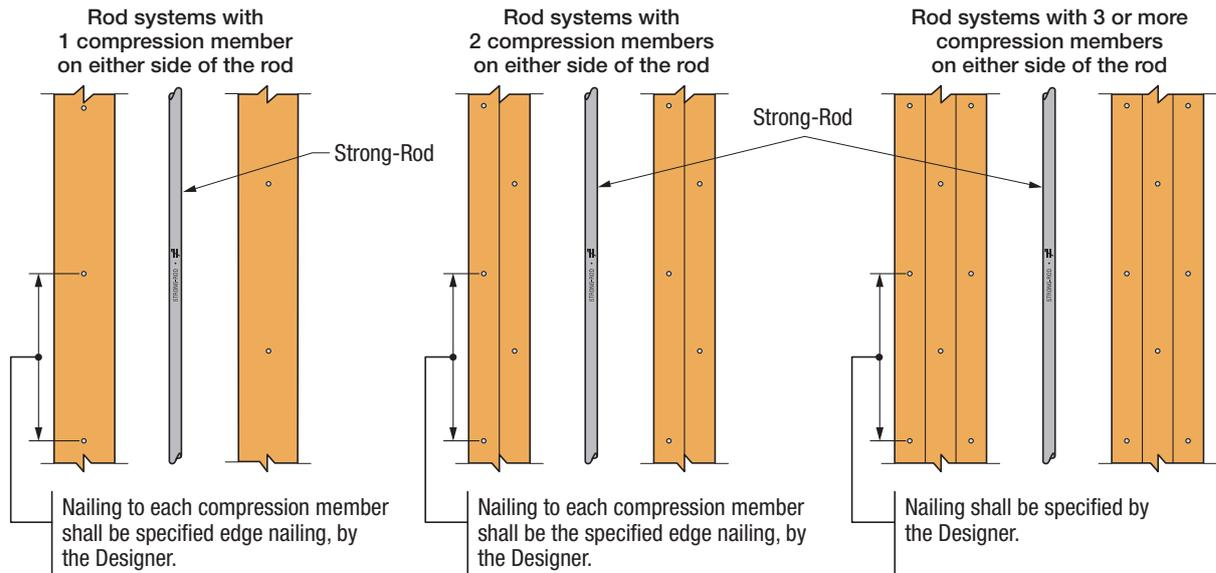

Moment Arm = Centre of Rod to Centre of Rod

Strong-Rod ATS

# Strong-Rod™ ATS Components

## From the Roof to the Foundation Anchorage

### Components for Anchor Tiedown System for Shearwall Overturning Restraint

Strong-Rod ATS Components

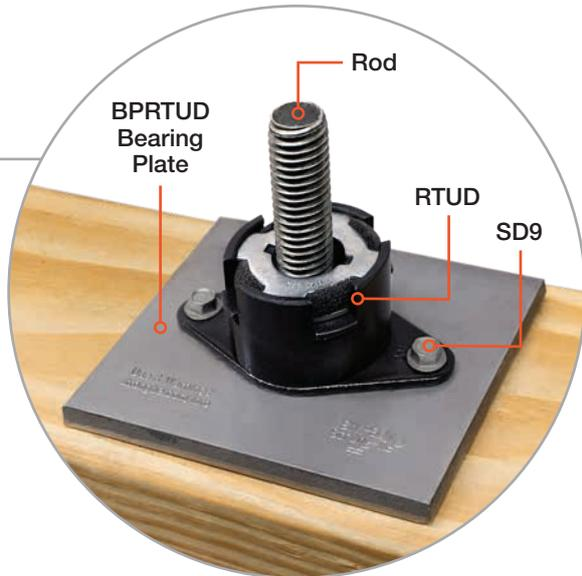
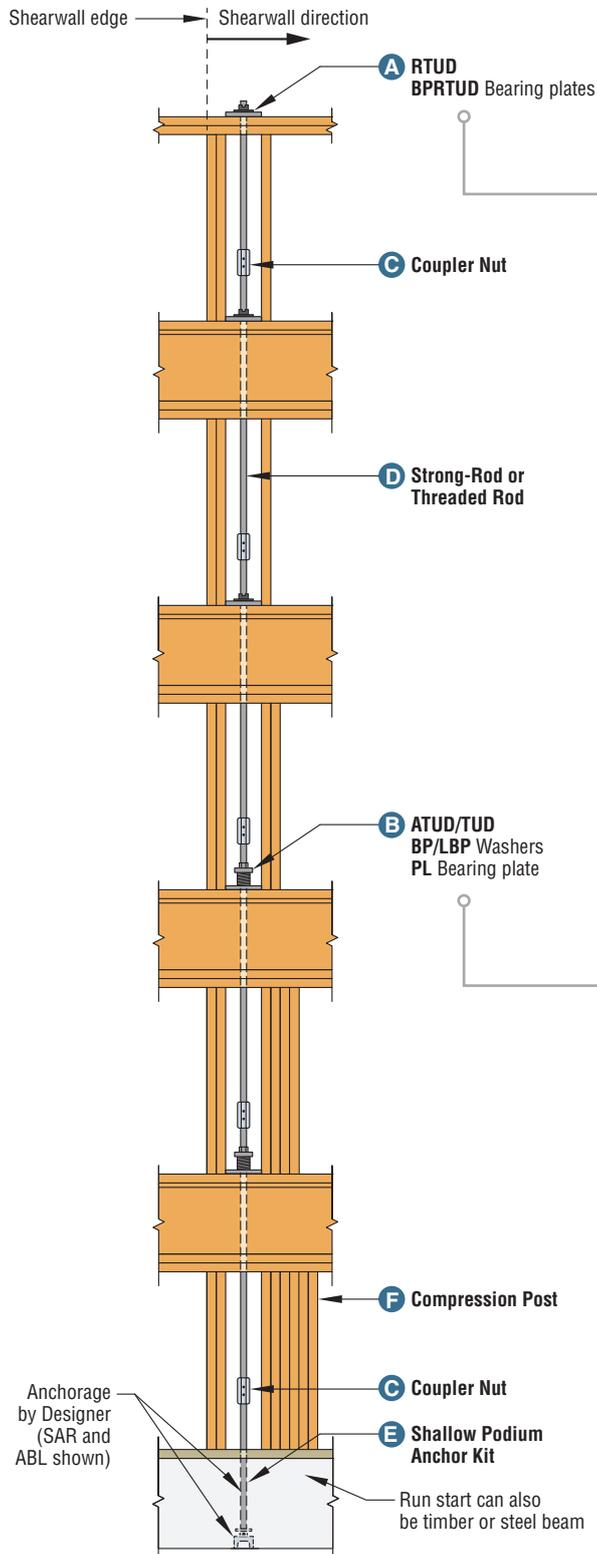

Ratcheting Take-Up Device Assembly

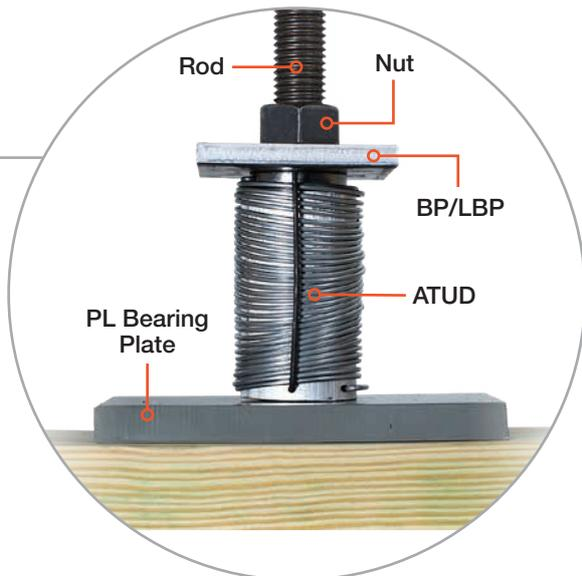

Take-Up Device Assembly

# Strong-Rod™ ATS Run Termination Details

## Top-Storey Termination Types

Three top-storey run termination options are provided to tailor the solution to the project's specific needs. The option chosen will depend on construction preference or structure conditions, such as sloped top plates, truss/rafter locations that may conflict with top-plate termination and available space above top plates for the take-up device assembly. The bridge block or strap termination are often necessary or preferred when the run stops below the top plate.

With the design support services we offer, Simpson Strong-Tie will also verify each specified run application and recommend the best termination method for the given project. Consider these variables when specifying run terminations.

### Bridge Block Connection

The bridge block connection is an alternative to terminating the rod-run on the uppermost floor top plate. The bridge block detail accommodates high loads with installation from the inside of the structure. The bridge block allows the installer to tie off the rod run without working from a ladder. There is no need to worry about having enough room in the roof space to allow for accumulated shrinkage. The bridge block should not be nailed to the full-height studs or the sheathing. One 4 mm skew nail to each jack stud is all that is required. Check the structural plans for the required fasteners from the jack to the full-height stud below the bridge block.

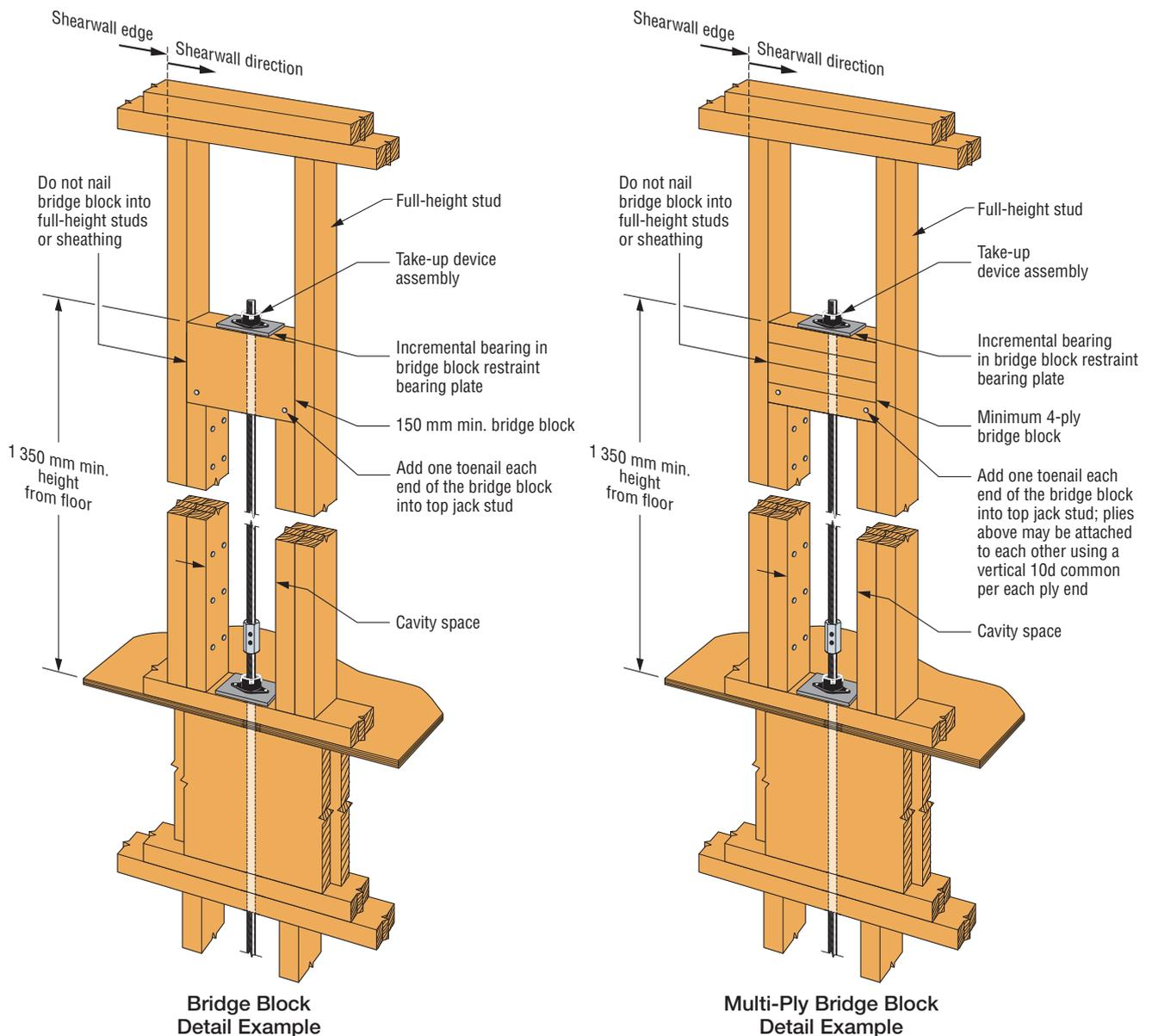

# Strong-Rod™ ATS Run Termination Details

## Top-Storey Termination Types (cont.)

### Top-Plate Termination

The traditional termination is at the top plate where there is enough roof space and the loads are not high enough to require a bridge block termination.

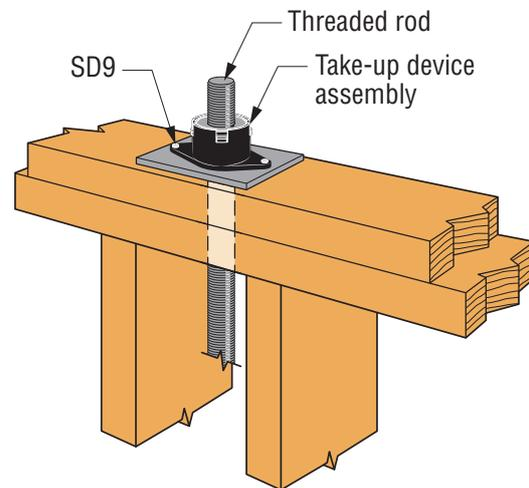

Top Plate Detail Example

### Strap Detail Termination

Straps can be used where loads are lower and framing conditions don't require a bridge block or top-plate termination.

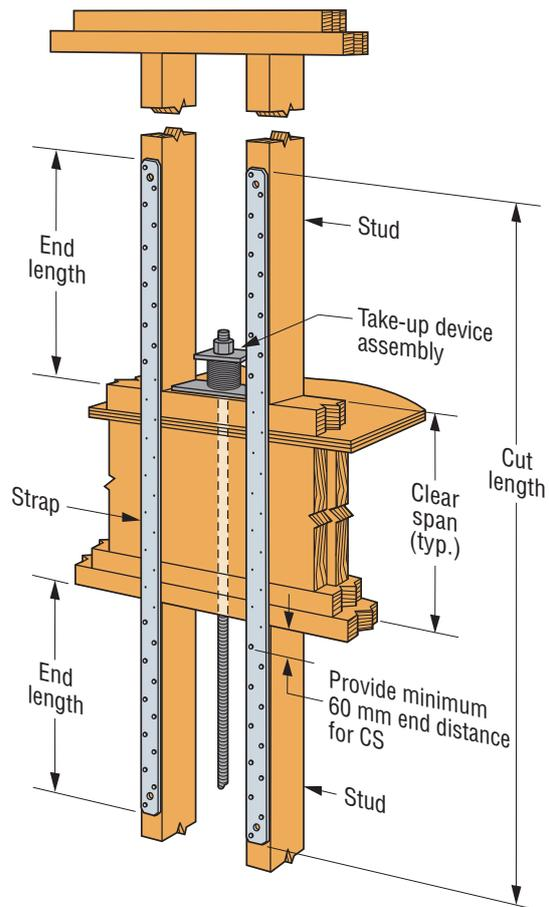

Strap Detail Example

# Strong-Rod™ ATS Components

## A RTUD Ratcheting Take-Up Device

The RTUD ratcheting take-up device is a cost-effective shrinkage compensation solution for continuous rod systems. The RTUD is code-listed for use with rod systems to ensure highly reliable performance in a device that allows for unlimited shrinkage. The RTUD should be hand installed until the base of the device fully bears on top of the BPRTUD. Once the fastener holes are aligned and the RTUD is flush, install the Strong-Drive® fasteners. Once the RTUD is installed, a series of internal threaded wedges enable the device to ratchet down the rod as the timber structure shrinks, but engage the rod in the reverse direction under tensile loading. Engagement is maintained on the rod by the take-up device, enabling the rod system to perform as designed from the time of installation.

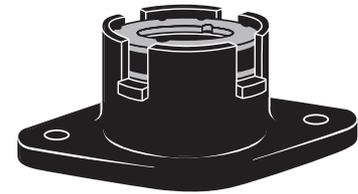

**RTUD**  
Patent Pending

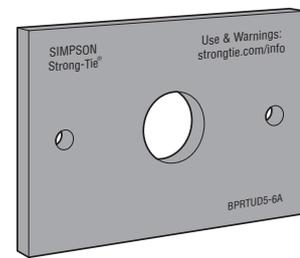

**BPRTUD**

### RTUD Models

Model No.	Threaded Rod Diameter in. (mm)	Dimensions (mm)			Compatible Bearing Plates
		Length	Width	Height	
RTUD3B	3/8" (10mm)	70	38	25	BPRTUD3-4B
RTUD4B	1/2" (13mm)	70	38	25	BPRTUD3-4B
RTUD5	5/8" (16mm)	98	51	35	BPRTUD5-6*
RTUD6	3/4" (19mm)	98	51	35	BPRTUD5-6*

- The attached components must be designed to resist design loads in accordance with the applicable code.
  - Thread specification for threaded rod used with the RTUD must be UNC Class 2A or 1A.
  - RTUD4B fastens to the timber plate with the BPRTUD bearing plate and (2) #9 x 38 mm or 64 mm Strong-Drive SD Connector screws. RTUD5-6 fastens to the timber plate with the BPRTUD bearing plate and (2) #9 x 64 mm Strong-Drive SD Connector screws.
- \* Refer to BPRTUD table below.

### BPRTUD Models

Model No.	Length (mm)	Width (mm)	Thickness (mm)	Hole Diameter (mm)
BPRTUD3-4B	90	76	6	16
BPRTUD5-6A	114	76	6	25
BPRTUD5-6B	140	76	13	25
BPRTUD5-6C	190	76	19	25

- Plate bearing area based on rod diameter plus 6 mm diameter drilled hole through timber plate below steel bearing plate. Reduce allowable load per code for larger holes.
- Bearing plate load capacity is based on the steel plate bearing on the timber bottom plate perpendicular to the grain and steel plate bending in cantilever action.

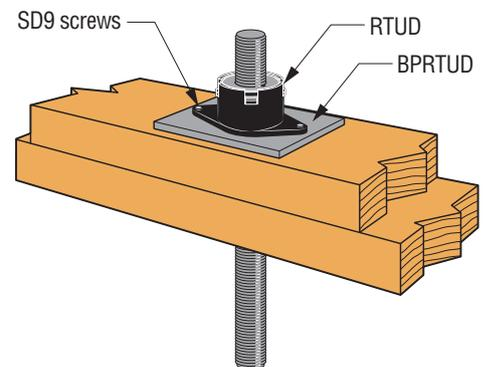

**Ratcheting Take-Up Device Assembly Installation**

### Naming Legend

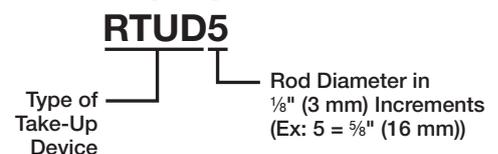

# Strong-Rod™ ATS Components

## B ATUD/TUD Take-Up Device

The ATUD (Aluminium) and TUD (Steel) expanding take-up devices are suitable for rod diameters from ½" (13 mm) up to 1¼" (45 mm) and shrinkage up to 75 mm. Expanding screw-style take-up devices provide the lowest device displacements. For installation, ensure that the activation pin is pointing up and facing toward the inside of the building space. The pin can be pulled anytime after the nut has been tightened onto the top bearing plate and must be pulled by the time the building is fully loaded. Shrinkwrap should remain on the device until the pin is ready to be pulled. Before activating an ATUD make sure the pin on the take-up device on the floor below has been pulled.

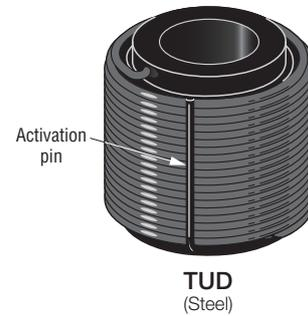
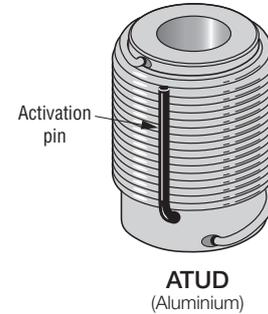

### ATUD/TUD Models

Model No.	Threaded Rod Diameter in. (mm)	Dimensions (mm)		Rated Compensation Capacity, (mm)	Bearing Plate Above ATUD/TUD	Bearing Plate Below ATUD/TUD
		Width	Length			
TUD10	1¼" (32mm)	60	57	25	BP	PL10
ATUD5	⅝" (16mm)	35	48	19	LBP	PL5
ATUD6-2	¾" (19mm)	44	79	50	BP	PL5/PL6
ATUD9	1⅛" (29mm)	54	57	25	BP	PL9
ATUD9-2	1⅛" (29mm)	54	98	50	BP	PL9
ATUD9-3	1⅛" (29mm)	54	127	75	BP	PL9
ATUD14	1¼" (45mm)	73	57	19	BP	PL14
ATUD14-2	1¼" (45mm)	76	98	50	BP	PL14

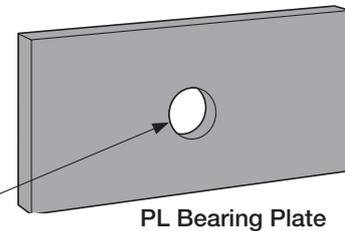

### Bearing Plate Models

Model No.	Dimensions (mm)			
	Width	Length	Thickness	Hole Dia.
BP5/8	64	64	6	17
BP3/4	70	70	8	21
PL5-3x3.5	76	89	10	17
PL5-3x5.5	76	140	13	17
PL6-3x3.5	76	89	10	21
PL6-3x5.5	76	140	13	21
PL9-3x5.5	76	140	13	30
PL9-3x8.5	76	216	22	30
PL14-3x8.5	76	216	22	46
PL9-3x12	76	305	32	30
PL14-3x12	76	305	32	46
PL9-3x15	76	381	38	30
PL10-3x15	76	381	38	33
PL14-3x15	76	381	38	46
PL9-5x5.5	127	140	13	30
PL14-5x5.5	127	140	13	46
PL9-5x8.5	127	216	22	30
PL14-5x8.5	127	216	22	46
PL9-5x12	127	305	32	30
PL10-5x12	127	305	32	33

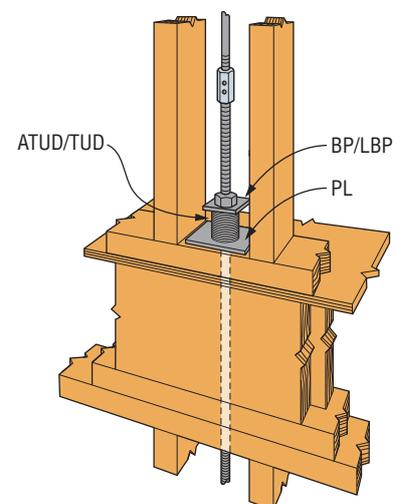

1. Secure BP and PL bearing plates to framing with washer and ATS-N\_nut over ATUD or TUD.
2. Secure ATS-BP bearing plates to framing with ATS-IN\_KT isolator nut kit.
3. Bearing plate loads are based on a hole through the timber plate below that is 6 mm larger in diameter than the rod.

# Strong-Rod™ ATS Components

## C Coupler Nuts

CNW and ATS-C coupler nuts are used to connect one threaded rod to another and connect to anchor bolts within the Strong-Rod Anchor Tiedown System for shearwall overturning restraint. Couplers are available in same rod size each end, as well as reducing couplers to allow for stepping of rod sizes up the rod run. Couplers are typically sufficient as black steel however a hot-dip galvanised option is available.

CNW and ATS-C coupler nuts exceed the tensile capacity of the corresponding standard-strength threaded rod. ATS-HSC coupler nuts exceed the tension capacity of the corresponding high-strength threaded rod. All couplers have a testing protocol to ensure that the proper loads are achieved.

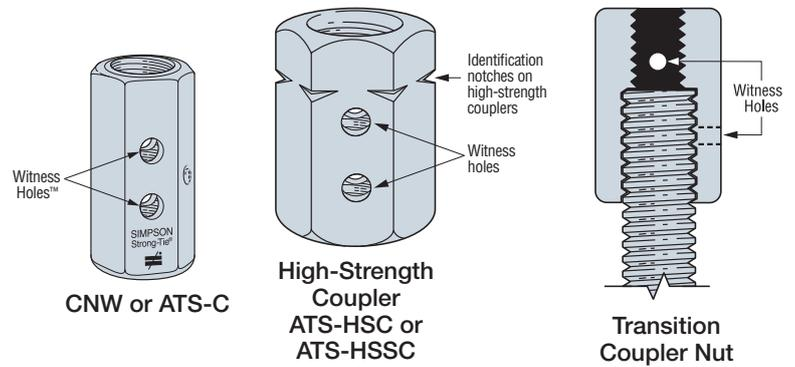

### Coupler Nut Models

Rod Dia in. (mm)	1/2" (13mm)	5/8" (16mm)	3/4" (19mm)	7/8" (22mm)	1" (25mm)	1 1/8" (29mm)	1 1/4" (32mm)	1 1/2" (38mm)	1 3/4" (45mm)	2" (51mm)
1/2" (13mm)	CNW1/2	ATS-HSC54	ATS-HSC64	ATS-HSC74	ATS-HSC84	ATS-HSC94	ATS-HSC104	ATS-HSC124	ATS-HSC144	ATS-HSC164
	ATS-HSC44									
5/8" (16mm)	ATS-C54	CNW5/8	ATS-HSC65	ATS-HSC75	ATS-HSC85	ATS-HSC95	ATS-HSC105	ATS-HSC125	ATS-HSC145	ATS-HSC165
		ATS-C64								
3/4" (19mm)	ATS-C64	ATS-C65	CNW3/4	ATS-HSC76	ATS-HSC86	ATS-HSC96	ATS-HSC106	ATS-HSC116	ATS-HSC126	ATS-HSC166
			ATS-C84							
7/8" (22mm)	ATS-C74	ATS-C75	ATS-C76	CNW7/8	ATS-HSC87	ATS-HSC97	ATS-HSC107	ATS-HSC127	ATS-HSC147	ATS-HSC167
				ATS-C104						
1" (25mm)	ATS-C84	ATS-C85	ATS-C86	ATS-C87	CNW1	ATS-HSC98	ATS-HSC108	ATS-HSC128	ATS-HSC148	ATS-HSC168
					ATS-C144					
1 1/8" (29mm)	ATS-C94	ATS-C95	ATS-C96	ATS-C97	ATS-C98	ATS-C199	ATS-HSC109	ATS-HSC129	ATS-HSC149	ATS-HSC169
						ATS-HSC199				
1 1/4" (32mm)	ATS-C104	ATS-C105	ATS-C106	ATS-C107	ATS-C108	ATS-C109	ATS-C1010	ATS-HSC1210	ATS-HSC1410	ATS-HSC1610
							ATS-HSC1010			
1 1/2" (38mm)	ATS-C124	ATS-C125	ATS-C126	ATS-C127	ATS-C128	ATS-C129	ATS-C1210	ATS-C1212	ATS-HSC1412	ATS-HSC1612
								ATS-HSC1212		
1 3/4" (45mm)	ATS-C144	ATS-C145	ATS-C146	ATS-C147	ATS-C148	ATS-C149	ATS-C1410	ATS-C1412	ATS-C1414	ATS-HSC1614
									ATS-HSC1414	
2" (51mm)	ATS-C164	ATS-C165	ATS-C166	ATS-C167	ATS-C168	ATS-C169	ATS-C1610	ATS-C1612	ATS-C1614	ATS-C1616
										ATS-HSC1616

1. All ATS couplers available in high strength, ATS-HSCxx with ATS-HSRxx or ATS-SRxH rod.
2. All ATS couplers available with one side with over-sized threads, ATS-Cxx-OST, ATS-HSCxx-OST, ATS-HSSCxx-OST.
3. All CNW couplers are zinc plated.
4. CNW couplers in the 14 and 16 series may be cylindrical.
5. All couplers available in hot-dip galvanised, CNx/x-x/x-HDG.

# Strong-Rod™ ATS Components

## D Steel Strong-Rods

Strong-Rod threaded rods are the tension transfer element within the Anchor Tiedown System for shearwall overturning restraint. Strong-Rod threaded rods are threaded on both ends, with the top end having 305 mm or 1219 mm of thread to allow for the distance that the rod sticks through the device. Information clearly etched on the shank allows easy identification in the field.

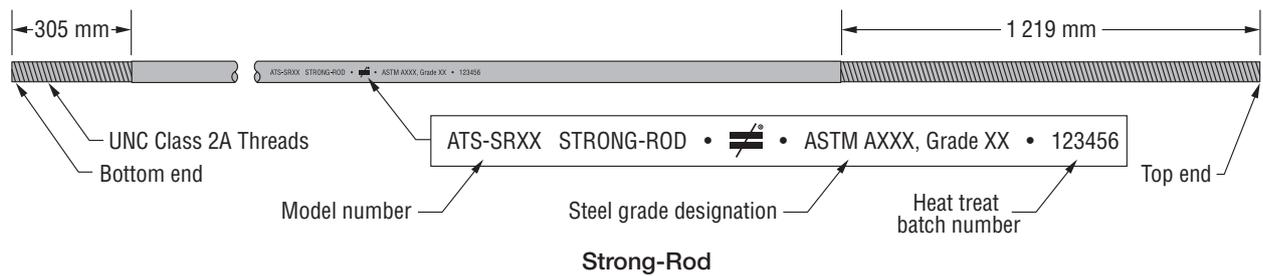
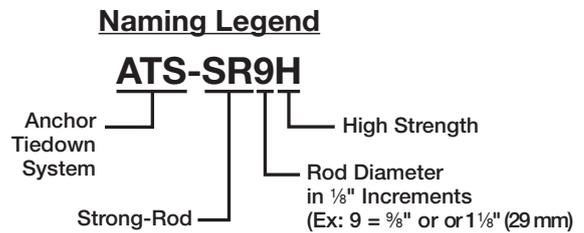

## Steel Fully Threaded Rods

Fully threaded rod (all-thread rod) is also available in standard-strength, high-strength and higher-strength rod material in diameters up to 2" (51 mm).

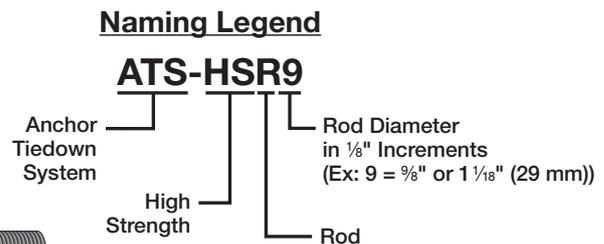

### Strong-Rod Product Data

Model No.			Rod Diameter (in.)	Approximate Metric Diameter (mm)
Standard Strength	High Strength	Super High Strength		
ATS-SR4	—	—	1/2"	13
ATS-SR5	ATS-SR5H	—	5/8"	16
ATS-SR6	ATS-SR6H	—	3/4"	19
ATS-SR7	ATS-SR7H	—	7/8"	22
ATS-SR8	ATS-SR8H	—	1"	25
ATS-SR9	ATS-SR9H	ATS-SR9H150	1 1/8"	29
ATS-SR10	ATS-SR10H	ATS-SR10H150	1 1/4"	32
ATS-SR11	ATS-SR11H	—	1 3/8"	35
ATS-SR12	ATS-SR12H	—	1 1/2"	38
ATS-SR14	ATS-SR14H	—	1 3/4"	45
ATS-SR16	ATS-SR16H	—	2"	51

### Fully Threaded Rod Product Data

Model No.		Rod Diameter (in.)	Approximate Metric Diameter (mm)
Standard Strength	High Strength		
ATS-R4	ATS-HSR4	1/2"	13
ATS-R5	ATS-HSR5	5/8"	16
ATS-R6	ATS-HSR6	3/4"	19
ATS-R7	ATS-HSR7	7/8"	22
ATS-R8	ATS-HSR8	1"	25
ATS-R9	ATS-HSR9	1 1/8"	29
ATS-R10	ATS-HSR10	1 1/4"	32
ATS-R11	ATS-HSR11	1 3/8"	35
ATS-R12	ATS-HSR12	1 1/2"	38
ATS-R14	ATS-HSR14	1 3/4"	45
ATS-R16	ATS-HSR16	2"	51

# Strong-Rod™ ATS Components

## E Shallow Podium Slab Anchor Kit

The Shallow Podium Slab anchor kit includes the patented Anchor Bolt Locator (ABL) and patent-pending Shallow Anchor Rod (SAR). Uniquely suited for installation to concrete-deck forms, the ABL enables accurate and secure placement of anchor bolts. The structural heavy hex nut is attached to pre-formed steel and becomes the bottom nut of the anchor assembly. The shallow anchor is provided with a plate washer fixed in place that attaches on the ABL nut when assembled and increases the anchor breakout and pullout capacity. The shallow anchor is easily installed before or after placement of the slab reinforcing steel or tendons. Where higher anchor capacities are needed such as at edge conditions or to meet seismic ductility requirements, the anchor kit is combined with anchor reinforcement.

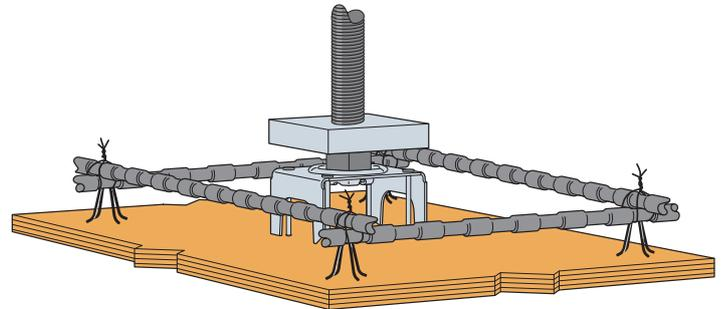

**Shallow Podium Slab Anchor Kit**

### Naming Legend

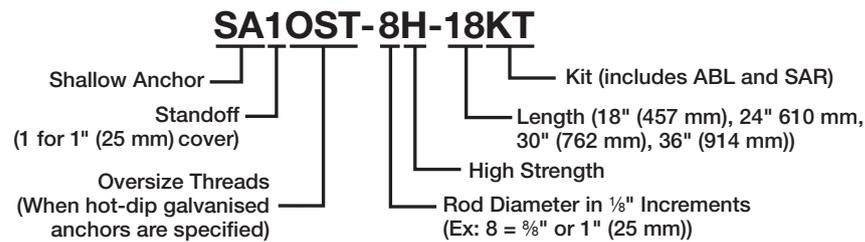

## SAR Shallow Anchor Rod

SAR anchor rods are for use with the ABL anchor bolt locator. They combine to make an economical podium-deck anchorage solution. Anchorage specification is per Designer.

### Features

- Proprietary and patent pending, pre-attached plate washer
- Available in standard or high strength
- Anchor rod diameters from 1/2" (13 mm) to 1 1/4" (32 mm)
- Standard lengths available 457 mm, 310 mm, 762 mm, or 914 mm
- Specify "HDG" for hot-dip galvanised

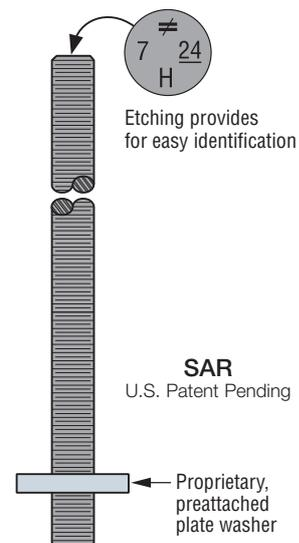

# Strong-Rod™ ATS Components

## E Shallow Podium Slab Anchor Kit (cont.)

### ABL Anchor Bolt Locator

The ABL enables the accurate and secure placement of anchor bolts on concrete-deck forms prior to concrete placement. The structural heavy hex nut is attached to a pre-formed steel "chair," which eliminates the need for an additional nut on the bottom of the anchor bolt.

#### Features

- Designed for optimum concrete flow
- Installs with (2) nails or (2) screws
- Provides 25 mm standoff (clear cover)
- Available for anchor rod diameter 1/2" (13 mm) to 1 1/4" (32 mm)
- For use with hot-dip galvanised anchor rods, specify "OST" for oversized threads

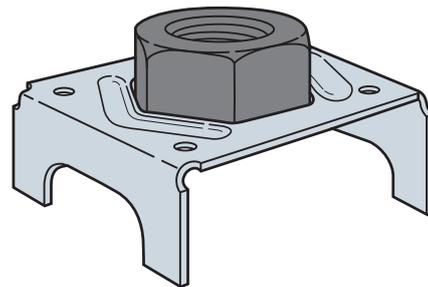

**ABL**  
U.S. Patent 8,381,482

#### ABL Models

Model No.	Anchor Bolt Diameter in. (mm)
ABL4-1	1/2" (13mm)
ABL5-1	5/8" (16mm)
ABL6-1	3/4" (19mm)
ABL7-1	7/8" (22mm)
ABL8-1	1" (25mm)
ABL9-1	1 1/8" (29mm)
ABL-10	1 1/4" (32mm)

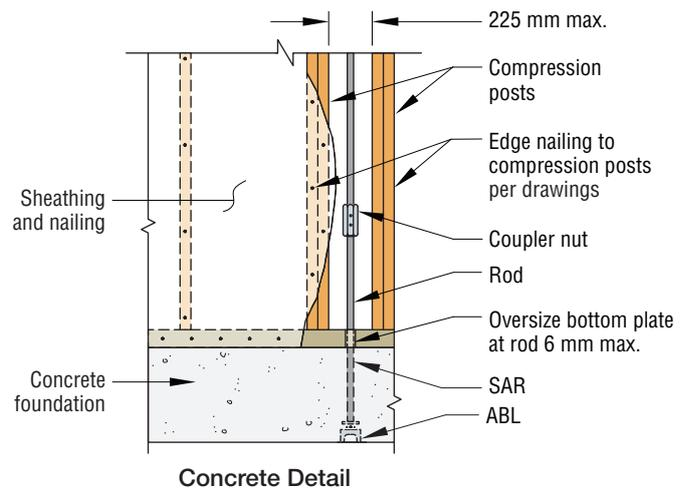

# Strong-Rod™ ATS Run Start Details

## Rod-to-Steel-Beam Connector

The rod-to-steel-beam connector (ATS-SBC) features a preattached high-strength steel threaded rod and weldable plate for use on projects where the run is to be anchored to steel beams. The new connector reduces the number of components from seven to two, saving contractors installation time and cost. The design of the steel beam and the stiffeners are the responsibility of the Designer.

**Material:** Plate — ASTM A572 Grade 50

**Threaded Rod:** High-Strength (ATS-HSR):  
Up to 1" (25 mm) diameter — ASTM A449  
Greater than 1" (25 mm) diameter — ASTM A193 B7 or F1554 Grade 105

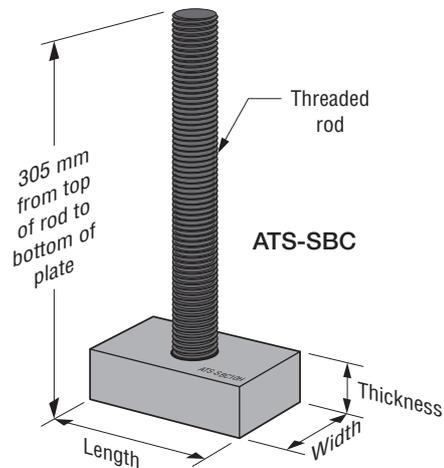

## Rod-to-Steel-Beam Connector (SBC)

Model No.	Rod Diameter in. (mm) <sup>3,4</sup>	Rod Height (mm)	Dimensions (mm)			Fillet Weld Size (mm)	Total Weld Length (mm) <sup>2</sup>
			Width	Length	Thickness		
ATS-SBC5H	5/8" (16mm)	305 (top of rod to bottom of plate)	76	76	19	6	127
ATS-SBC6H	3/4" (19mm)			76	25	8	127
ATS-SBC8H	1" (25mm)			76	32	8	254
ATS-SBC10H	1 1/4" (32mm)			127	38	8	356
ATS-SBC11H	1 3/8" (35mm)			152	38	8	406
ATS-SBC12H	1 1/2" (38mm)			178	44	8	457

- No further increase in allowable load is permitted.
- The weld length for the ATS-SBC5H and ATS-SBC6H requires only two opposing sides of the plate to be fillet welded full length less a 6 mm holdback from each of the edges. For the ATS-SBC8H up to the ATS-SBC12H, all four sides must be fillet welded full length less a 6 mm holdback from each of the edges.
- For purposes of coupling on to the rod above, the ATS-SBC threaded rod specification is UNC Class 2A, in accordance with ANSE/ASME B1.1.
- The minimum tensile strength,  $F_u$ , of the threaded rod for the ATS-SBC5H, ATS-SBC6H and ATS-SBC8H is 120 ksi, and for the ATS-SBC10H, ATS-SBC11H and ATS-SBC12H it is 125 ksi. For rod steel ASTM specifications, see reference above.
- A minimum flange thickness of 6 mm is required for the structural steel beam.

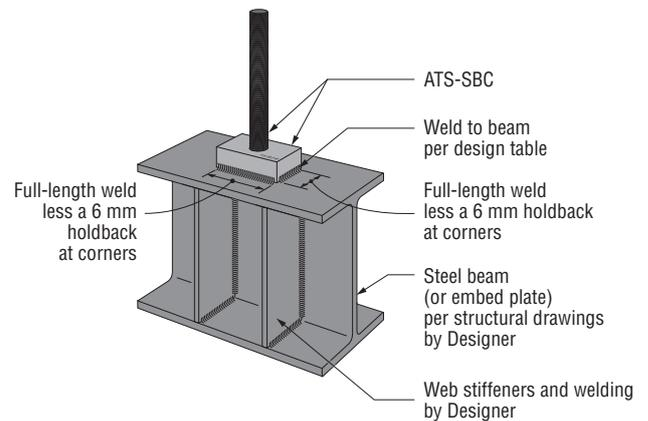

**Typical Rod-to-Steel-Beam Installation**

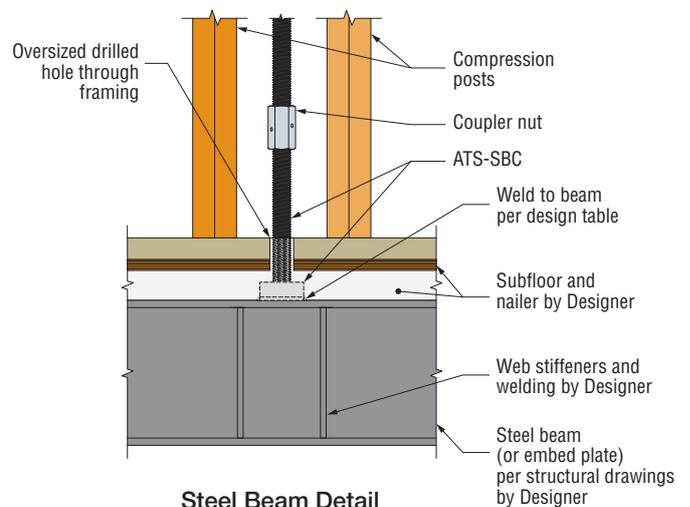

**Steel Beam Detail**

# Strong-Rod™ ATS Run Start Details

## Timber-Beam Plate

The WBP timber-beam plate is for projects where the rod run attaches to timber beams. The centre hole of the bearing plate has internal threads to receive the threaded rod from above, and the plate spreads the load across the underside of the timber beam. Two SDS Heavy-Duty Connector screws (provided with the kit) are to be installed through the WBP fastener holes and into the timber beam to support the weight of the bearing plate and rod above. This eliminates the need for an additional smaller bearing plate and nut on the top side of the beam. This unique connection also provides a fixed point at the very bottom of the rod run, allowing the take-up devices above to address shrinkage of all the timber framing including any from the timber beam itself. The heavy hex nut provided with the WBP is required to fully engage the tensile capacity of the rod above.

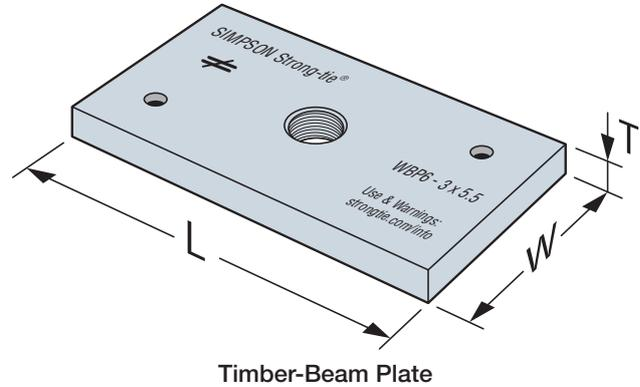

Timber-Beam Plate

**Material:** ASTM A36

**Finish:** Grey primer

### Timber-Beam Plate (WBP)

Model No.	Dimensions (mm)			Compatible Rod Diameter in. (mm)	SDS Screw Length in. (mm) <sup>1</sup>
	Width	Length	Thickness		
WBP4-3X3.5	76	89	13	½" (13mm)	76
WBP5-3X3.5	76	89	13	⅝" (16mm)	76
WBP6-3X5.5	76	140	13	¾" (19mm)	76
WBP7-3X8.5	76	216	22	⅞" (22mm)	114
WBP8-3X12	76	305	32	1" (25mm)	114
WBP8-3X15	76	381	41	1" (25mm)	114
WBP8-5X5.5	127	140	13	1" (25mm)	114
WBP9-5X8.5	127	216	22	1⅛" (29mm)	114
WBP9-5X12	127	305	32	1⅛" (29mm)	114
WBP10-5X12	127	305	32	1¼" (32mm)	114

- Centre hole is a UNC-2B tapped hole.
- SDS screws are needed to fasten the rod and WBP assembly to the wood beam (SDS screws provided).

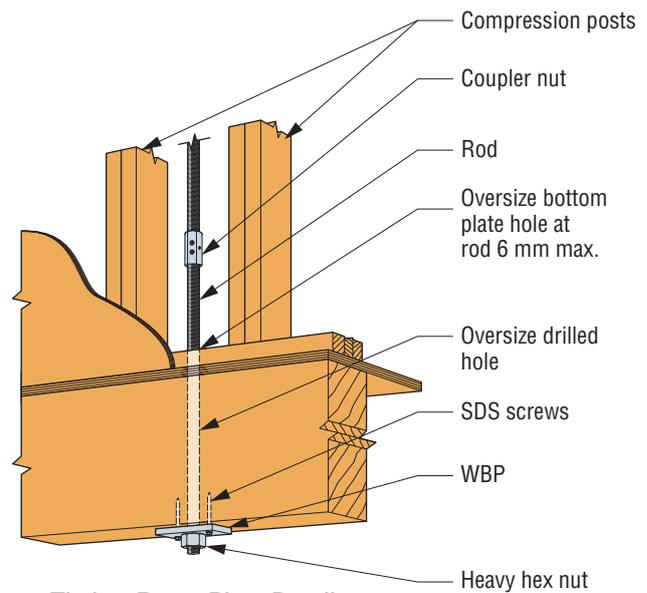

Timber-Beam Plate Detail

## Rod System Design Considerations for Shearwall Overturning Restraint

When specifying Simpson Strong-Tie® Strong-Rod™ Anchor Tiedown System for shearwall overturning restraint, one should consider several factors to ensure that the system is configured to meet the design intent and building codes. These factors apply to each method of specification. The list on the left below delineates the general design requirements for any continuous rod tiedown system used to restrain overturning forces in stacked shearwalls. The list on the right provides a description of how our system is designed and of the services we provide in order to meet the general strength and performance requirements.

### General Shearwall Overturning Restraint Rod System

#### Designer Responsibilities

- Calculating lateral forces in each floor and roof diaphragm (at diaphragm level) of structure
- Locating shearwalls in each level of the structure
- Calculating cumulative overturning tension and compression forces for each shearwall
- Design and specification of compression posts
- Design and specification of anchorage to foundation including anchor bolt diameter and grade of steel
- Drift Check (Seismic)

#### Information Required to Design Rod Tiedown System

- Building code edition
- Building jurisdiction deformation requirements, (if applicable) such as rod elongation and system deformation limits
- Cumulative overturning tension/compression forces
- Estimate of timber shrinkage per level
- Timber framing including size and species of stud, post, top and bottom plates as well as floor system type and depth
- Wall height (finish floor to ceiling)
- Anchor bolt size and grade at foundation
- Anchor bolt coating
- Run start above foundation such as steel or timber beam
- Run termination preference at top of run (top plate, bridge block, strap)
- Floor plan shearwall layout

#### Required Rod System Design Checks

- Tensile capacity of rod
- Bearing plate capacity
- Travel capacity of shrinkage take-up device
- Load capacity of shrinkage take-up device
- Rod elongation per level using net tensile area of rod
- Total system deformation per level
- Verification that rod elongation plus take-up device displacement is less than or equal to 5 mm.

#### Anchorage Design

- Anchorage design tools are available
- Anchorage design information conforms to Simpson Strong-Tie testing

### Simpson Strong-Tie Strong-Rod Design Checklist

#### Rod Tension (Overturning) Check

- Rods at each level designed to meet the cumulative overturning tension force per level as delivered from bearing plates and transfer it to the foundation
- Standard and high-strength steel rods designed not to exceed tensile capacity
- Rod elongation limits (see below)

#### Bearing Plate Check

- Bearing plates designed to transfer incremental overturning force per level into the rod
- Bearing stress on timber member limited in accordance with AS1720.1 or NZS3603 to provide proper bearing capacity and limit timber crushing
- Bearing plate thickness has been sized to limit plate bending in order to provide full bearing on timber member

#### Shrinkage Take-up Device Check

- Shrinkage take-up device is selected to accommodate estimated timber shrinkage to eliminate gaps in the system load path
- Load capacity of the take-up device compared with incremental overturning force to ensure that load is transferred into rod

#### Movement/Deflection Check

- System deformation is an integral design component impacting the selection of rods, bearing plates and shrinkage take-up devices
- Rod elongation plus take-up device displacement is limited to a maximum of 5 mm per level or as further limited by the requirements of the engineer or the governing authority having jurisdiction
- Total system deformation reported for use in  $\Delta_a$  term (total vertical elongation of wall anchorage system) when calculating shearwall deflection
- Both seating increment ( $\Delta_R$ ) and deflection at allowable load ( $\Delta_A$ ) are included in the overall system movement.

#### Optional Compression Post Design

- Compression post design can be performed upon request along with the Strong-Rod System
- Compression post design limited to buckling or bearing perpendicular to grain on timber plate

# Strong-Rod™ ATS

## Anchor Tiedown System Design Example

The following design example illustrates the steps that are used when the designer determines lateral loads to the shearwall  $F_x$ , using proper code provisions, and then determines the resultant level wall shear and overturning forces as distributed by the appropriate gravity and seismic code load combinations. These loads are then used by the designer to determine cumulative tension (for rod design), incremental bearing (for take-up device and bearing-plate design) and cumulative compression. These will then be used as inputs to design the specific continuous Strong-Rod tiedown system as the tension restraint for the shearwall.

During the design process of the overall structure, the Designer will have already determined the wall length, minimum wall height-to-width ratios, sheathing thickness and grade, nailing schedule,  $\Delta_a$  for horizontal drift (or Designer to assume  $\Delta_a = 5$  mm), floor-to-floor height (including floor depth to determine plate height) and all other requirements in accordance with the applicable building code.

Strong-Rod ATS Design

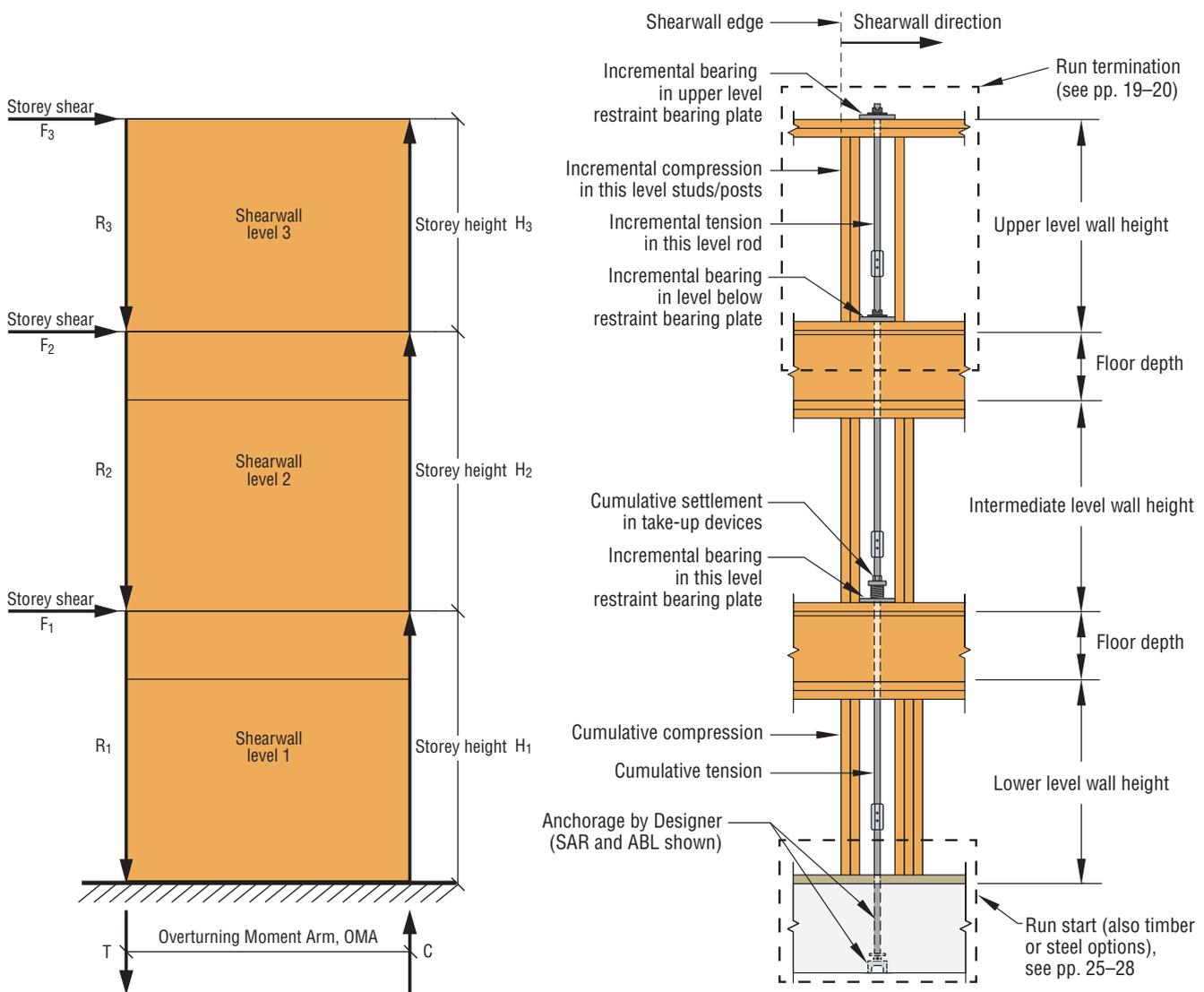

Figure 1

Shearwall Free Body Diagram Example

### General Steps for Designing the Anchor Tiedown System

1. The Designer will calculate the cumulative overturning force at each level. These forces will be used to determine the end-of-wall incremental bearing, cumulative tension and cumulative compression.
2. Tabulate the incremental bearing, cumulative tension and cumulative compression and provide these values in the Designer structural drawing set.

# Strong-Rod™ ATS

## Anchor Tiedown System Design Example (cont.)

3. Determine the tension rod size, rod strength and rod elongation. The demand tension loads used for rod design are the cumulative tension uplift loads.
4. The appropriate couplers should then be selected based on rod strength and diameter. These will be used to connect threaded rods to one another as well as coupling to the anchor bolts within the rod tiedown system. See Figure 2. Note that Simpson Strong-Tie coupler nuts exceed the tensile capacity of the rod.
5. Next, determine the bearing-plate sizes and capacities. These plates are designed to transfer the incremental bearing loads from the floor below via bearing from the top plate below, then through the blocking and the bottom plate and into the rod via either a nut or an attached ratcheting device. See Figure 3.

The design is based both on:

- a. Timber bearing perpendicular to the grain of the timber bottom plate.  
The bearing area should consider the hole diameter in the steel plate as well as the drilled hole through the timber bottom plate. Simpson Strong-Tie recommends maintaining the drilled hole such that it is no more than 6 mm greater in diameter than the steel rod.
- b. Steel-bearing-plate bending where the cantilever length can be taken from the face of the take-up device.

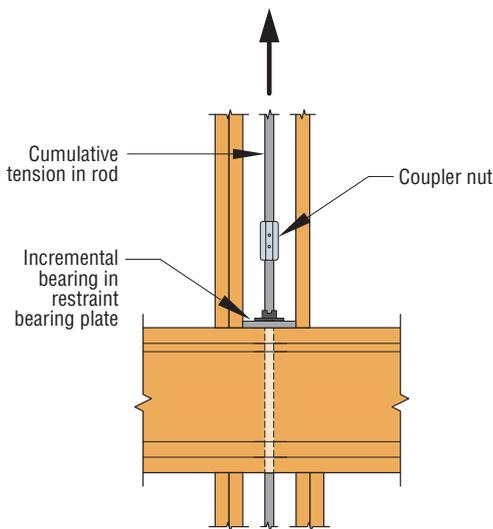

**Figure 2**  
**Rod Coupler**  
**Detail Example**

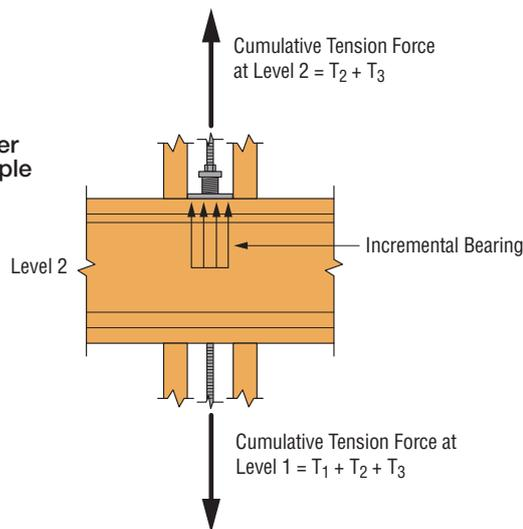

**Figure 3**  
**Bearing Plate Free**  
**Body Diagram Sample**

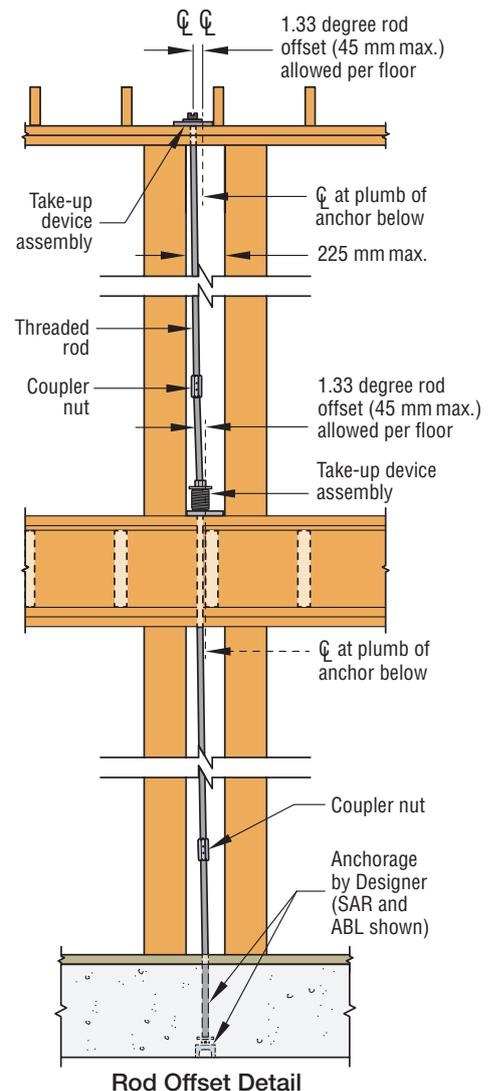

**Rod Offset Detail**

## Anchor Tiedown System Design Example (cont.)

6. Bottom plate crushing/deformation (See Figure 4) should then be determined following the provisions of AS1720.1 or NZS3603.

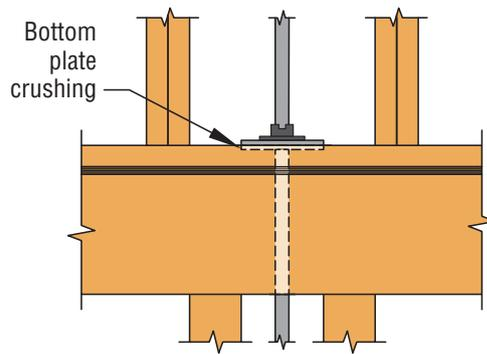

**Figure 4**  
**Bottom Plate Crushing**

7. Next, determine the take-up device type and size. The total shrinkage in timber-framed buildings can be estimated by adding up cross-grain shrinkage of the wall plates, sills and floor joists, as well as the small fraction of shrinkage that comes from the studs and posts. This calculation is important for avoiding gaps in the system as the timber shrinks while the rod doesn't. Also, note that shrinkage is cumulative going up the building.
  - a. In order to compensate for building shrinkage and to help meet the shearwall code drift requirements, take-up devices are necessary with most timber structures greater than two stories tall. Take-up devices are either ratcheting devices that have unlimited shrinkage capacity or expanding devices that have a designated shrinkage capacity. The incremental bearing load shall be used to design the strength of the device.
  - b. The other variables used for selecting the take-up device are the associated rod diameter, seating increment  $\Delta_R$  and deflection at the allowable load,  $\Delta_A$ , where  $\Delta_T = \Delta_R + \Delta_A (P_D/P_A)$ .
8. Finally, a system deflection check will be conducted.
  - a. This system deflection check limits rod elongation and the shrinkage compensating device deflection to 5 mm at each level or between restraints unless the shearwall drift is determined to be within code limits.
  - b. The 5 mm vertical displacement limit may be exceeded when it can be shown that the code storey drift limit is not exceeded.

## Anchor Tiedown System Design Example (cont.)

9. Design of the shearwall chord boundary members, or the compression post members that are part of the shearwall associated with the continuous rod system. These timber members are the vertical studs or posts at the end of the shearwalls that perform as the chords or boundary members of the system. The load path is such that the overturning moment is resolved into a tension/compression couple, creating equal and opposite axial tension and compression forces in each end of the wall. The Designer is responsible for establishing appropriate tributaries for the dead and live loads that are resolved into the cumulative compression — as well as the proper resultant lateral load — and for then utilising the correct code load combinations. Key aspects to the end-of-wall compression member design are:

- a. Determine the proper Overturning Moment Arm (OMA). In general, this length is measured from the centre line of the tension rod at one end of the wall to the centre of gravity of compression end at the other end of the wall.
- b. Refer to AS1720.1 or NZS3603 for the proper timber design variables for the proper  $N_{d,p}$  perpendicular-to-timber-grain design equation.
- c. Determine the Parallel-to-Grain Capacity.
- d. Compute the compression capacity of the end-of-wall timber members and determine the specific timber members to be called out for use in the design.
- e. Establish either a symmetrical compression member layout or an asymmetrical layout.
- f. For the asymmetrical configuration, as a general rule when using typical platform framing, a maximum of six additional studs (or 225 mm) may be used at the interior studs as compared to the interior stud pack above.

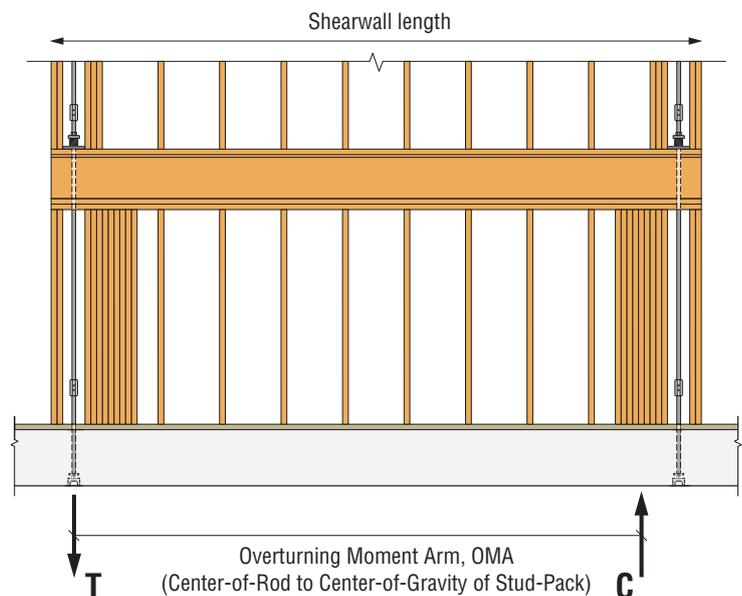

**Figure 5**  
**Overturning Moment Arm**

10. In summary, whenever you're designing an anchor tiedown system, it's important to understand the multiple design considerations.

- a. Know the difference between cumulative tension and incremental bearing.
- b. Estimate the vertical timber shrinkage and coordinate that with the rated travel distance of the specified take-up device.
- c. Ensure that rod elongation is being determined using net tensile area of the rod.
- d. Know the proper design checks for the steel bearing plate (bearing and bending).
- e. Understand the different take-up device options.
- f. Ensure that the system deflection is being evaluated and do not permit skipping of floors.

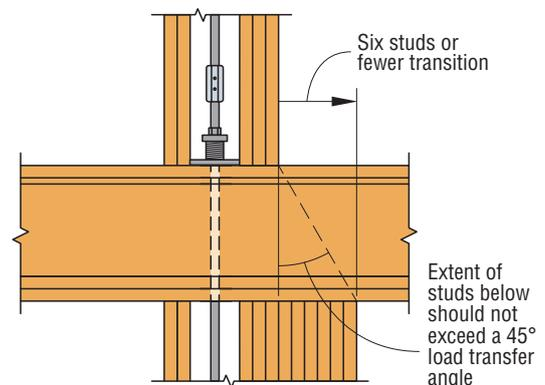

**Figure 6**  
**Compression Post**  
**Floor-to-Floor Transition**

# Specifying Rod Systems for Shearwall Overturning Restraint



## Methods for Specifying

We recognise that specifying the Simpson Strong-Tie Strong-Rod™ Anchor Tiedown System (ATS) for shearwall overturning restraint is unlike choosing any other product we offer. You must first address several design questions and considerations to ensure that the system will be configured to meet the design's intent. For example, when determining whether to use Strong-Rod Systems or conventional holdowns and strapping, a Designer must determine the project's incremental and cumulative loads or specification of elongation and system deflection limits. The Designer will need to determine the compression posts, sheathing thickness and grade, nailing schedule, horizontal drift, and meet all other requirements in accordance with the applicable building code.

For more on these issues and many others, please visit [strongtie.com/srs](http://strongtie.com/srs).

### Your Partner During the Project Design Phase

During the Designer's preparation of the construction documents, Simpson Strong-Tie can be contacted to assist with the most cost-effective customised runs. These runs include detailed design calculations for each shearwall overturning restraint requirement and design drawings with all the necessary details to install the ATS system. The Design engineer may work closely with Simpson Strong-Tie to provide all the necessary information required to design the system.

Some of the items required to design the ATS system are:

- The design code for the project
- Bottom plate species and size
- System elongation limits at each level
- Type of floor system and depth
- Cumulative tension and compression loads at each level
- Wall heights
- Anchor diameter
- Type of run start and termination



# On site for your success

Ensuring the integrity of mid-rise structures against seismic and wind forces requires many complex design considerations unique to each project. Our onsite knowledge is the perfect complement to our Strong-Rod systems. With Simpson Strong-Tie field support, you'll have highly skilled experts on the jobsite to help you manage project changes,

answer product questions and supply engineering advice. We offer training, conduct pre-construction meetings and provide a project overview so that your team can build the safest structure possible while keeping material costs low and installation easy. When it comes to onsite support, we're there every step of the way.



Phoenix Apartments — Rouse Hill, Sydney Australia