

Section 1 – Introduction

This application guide describes standard procedures for installing Johns Manville (JM) TPO roofing systems and has been prepared for:

The Roofing Mechanic

JM recognizes that the success and long-term performance of our roofing systems depend upon the personal skill, experience and knowledge of the roofing mechanic.

JM TPO roofing systems offer important advantages for roofing crews. Roofing membranes can be installed year-round with proper roof deck preparation and some adjustments for weather conditions.

How to Use This Guide

This guide is divided into five sections:

1. Introduction
2. Seaming and Fastening Methods
3. Installing Mechanically Fastened and Fully Adhered Roof Systems
4. Roof Penetrations
5. Flashing Installation

This guide is designed for your convenience. These step-by-step instructions and illustrations should answer your installation questions and help you maintain top-quality craftsmanship when applying a JM TPO roofing system.

JM TPO Membranes

JM TPO Membranes are manufactured to meet a wide range of roof construction requirements. These membranes are used for mechanically attached and fully adhered roofing systems and are not intended for ballasted roofs.



Each membrane sheet is marked along the edge with overlap lines. These lines indicate the minimum overlap required and the area to be welded. Mechanically attached methods using in-lap fastening require a larger overlap. A minimum 1½" (3.81 cm) welded seam is required for all systems.

Mechanically Fastened and Fully Adhered Roofs

There are two basic types of JM TPO roofing systems: mechanically fastened and fully adhered.



Mechanically fastened systems secure the membrane to the roof with special fasteners, which vary depending on the roof deck material.

Several construction variations are possible with mechanically fastened roofs.

In fully adhered roofing systems, the membrane is bonded to the substrate with special adhesives.

Roof Preparation (Re-Roofing)

Proper roof deck preparation is essential to simplify installation and prevent future conditions that may lead to roof leaks.

Carefully sweep all roof surfaces to remove all debris and dirt. Make sure the roofing area is completely smooth. Cut out large blisters on asphalt or coal tar pitch roofs. Repair holes or cracks in concrete greater than ¼" (6.35 mm) wide with non-shrink grout.

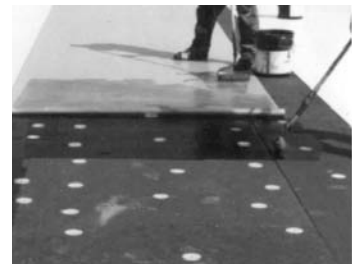

A slipsheet is often used under the membrane. It provides a smooth surface and acts as a separator layer between an existing, damaged roof and the new roof to be applied. JM TPO Membrane application may require the installation of a separator material between the JM TPO Membrane and the substrate. This is most commonly achieved by the installation of a roof insulation board or an approved separator sheet. JM recommends a slipsheet on all asphalt roofs and insulation for all coal tar roofs. Remove loose nails and sharp ridges or burrs on concrete, if no insulation is used.

When using mechanical fasteners, if you are unsure of the deck condition, pull-out tests of the fasteners being used must be performed to confirm sufficient pull-out strength. Contact your supervisor, who will obtain full details from the JM Roofing Services Group.

Equipment

The following equipment may be needed to install JM TPO roofing systems:

Hammer drill	Scissors
Electric drill	Wire brush
Rivet gun	Chalk line
Snips	Shovel
Gravel pusher	Pliers
Hammer	Tongs
Pull-out tester	Gravel-moving equipment
Hand-held hot air welder	Lawn or linoleum roller
Brooms (soft and stiff)	Drill bits (carbide, steel)
Screw gun	Reciprocal saw
Gloves	Grounded extension cords
Measuring tape	Seam probe
Ladder	First-aid kit
Portable generator	Utility knife
Rope	Screwdriver set
Eye protection	Rubber mallet
Wood saw	Rags
Metal crimpers	Writing/marketing instruments
Vise-grip pliers	T-square
Solvent-resistant pan	Rollers and brushes

Section 2 – Seaming and Fastening Methods

This section describes welding and fastening methods used to install JM TPO roofing systems, including: installing hot air welding membrane sections, using prefabricated JM TPO-Coated Metal parts, seam testing, using fasteners to anchor the roof to the roof deck, and adhesive application of the membrane.

Seaming Precautions

Before welding, ensure area is clean and dry. Remove dirt or contamination before welding by using low-sudsing soap and water followed by JM Single Ply Membrane Cleaner or other membrane cleaner. As a last resort, cut away the affected sheet section and replace with new material.

If JM TPO Membrane has been exposed for a period greater than 24 hours and/or compromised by dirt or debris, the area shall be cleaned with JM Single Ply Membrane Cleaner prior to welding to ensure full weld strength.

Hot air welding equipment is required to make all field seams. **Welding speeds will be slower in high humidity conditions or at low temperatures.**

General Suggestions to Avoid Problems in Cold Weather (Below 50°F [10°C])

1. Store all JM TPO materials in warm, dry areas to avoid condensation problems that could affect weld quality. Store away from open sparks and flame sources.
2. Take at least twice the usual number of seam samples to test for peel resistance, since the possibility of inferior welds is greater.
3. Thoroughly dry all weld surfaces prior to welding.
4. Exercise caution when walking on dew, frost, ice or snow-covered roofs, since the membrane may be extremely slippery.

How Hot Air Welding Works

Hot air welding works by applying very hot air to the membrane surfaces, softening and fusing the surfaces together, thereby creating a permanently fused, bonded sheet. One of the major advantages of hot air welding is the fact that the seam comes to full weld strength immediately.

Reducing Stresses on Welded Seams

Seams must be loaded in shear and not in peel. A shear load would be in the plane (horizontal) of the roof membrane. A peel load would be lifting the seam perpendicular to the roof.

All roofs expand and contract during temperature changes. This can produce mechanical stress in the membrane. It is important to make welds that do not cause peel stresses to occur.

The correct and incorrect methods for welding at the roof surface and side corners are described below.

Correct: Weld the membrane to horizontal surface of the JM TPO-Coated Metal or membrane flashing, producing only horizontal stress (shear stress) on the welded seam. This also helps transfer stress to the roof structure.

Incorrect: The weld is subject to vertical stress (peel stress). Peel stresses weaken, and may eventually rupture the welded seam.

Hand-Held Hot Air Welding

Membranes can be hot air welded in many different conditions, including cold weather. A hand-held hot air welder is especially useful when welding membrane sections at corners or on vertical surfaces. Hand-held hot air welders are also used to weld membrane sections together or to weld membrane to JM TPO-Coated Metal, which has factory-laminated JM TPO Membrane on its top side and a protective coating on the back.



Machine Hot Air Welding

Large robotic hot air welders are used for high-speed hot air welding of membrane seams. A variable speed control for the electric motor lets you adjust the machine's travel speed along the seam. Movement of the welder along the seam is determined by heat setting based on air temperature.



To hot air weld, insert the nozzle fully into the 2" (5.08 cm) weld zone, and raise the back wheel to allow the machine to ride on its two drive wheels. Dial in the desired temperature and speed.

To steer the tool along the seam, use the welder's guide wheel. Watch the guide closely to make sure the machine stays on line.

Surface irregularities can cause the pressure wheel to move slightly away from the seam. If this happens, tap lightly on the machine's upper handle to maintain travel in a straight line.

Consult the hot air welder manufacturer for specific recommendations.

As the hot air nozzle moves along the weld area, a wide drive wheel behind the nozzle applies immediate and uniform pressure to the heated area. The drive wheel presses the heated seam area together. Check all machine hot-air-welded seams for voids, and patch with JM TPO Membrane and a hand-held hot air welder. Seal all cut edges, including factory-cut edges, with JM TPO Edge Sealant. Always run several test welds with the machine each time you begin welding and/or if the machine has been shut down for any length of time.

With either method, perform a 4' or 5' (1.22 m or 1.52 m) test weld before beginning each day's application and any time the hot air welder has been turned off for any length of time. This checks peel strength, consistency, weld width, etc., and allows for welder adjustment.

First, adjust the temperature of the hot air welder to produce a shiny membrane surface without burning the membrane. Fully insert the tip of the hot air welder into the seam, moving it slowly backwards. As the membrane softens, press the membrane surfaces together with a silicone rubber roller from the inside edge to the outside edge of the seam. Take care to produce a continuous weld with no air pockets.

Repairing Scorched Membranes

If the membrane surface is overheated, a good weld cannot be achieved. The burned or discolored membrane must be patched.

To repair a burned section, cut away the damaged material at least 1" (2.54 cm) beyond the burned edges. Patches should be cut to extend at least 3" (7.62 cm) beyond all damaged edges. Allow for a minimum 1½" (3.81 cm) weld width on all sides.

Center the patch over the cut area and weld to the membrane, using normal welding procedures. Cut all patches in a square or rectangular shape with round corners for a neat, finished roof appearance.

T-Joints, Testing and Sealing Seams

T-Joints

The t-joint occurs where three layers of membrane overlap. Voids may occur along the edge of the middle layer of membrane. To close the void, gently lift the upper membrane sheet and apply sufficient hot air to heat the membrane surfaces. Then, using the edge of a silicone rubber roller, roll and fuse the upper membrane surface into the lower membrane. A crease developed along the intersection of the two surfaces indicates a proper weld.

Testing Seams

Hot air welded seams may be tested as soon as seams cool. After welding, carefully test every seam and t-joint along its entire length. Do this by running a blunted scratch awl, cotter key puller, or other round-tipped, blunted tool along the seam edge while applying firm, steady pressure. It is imperative to avoid scoring the membrane that has just been welded. Any penetration of the probe into the seam indicates a void in the weld, which must be patched. Continuous seam probing will tend to sharpen the tip of the probe, so it is important to blunt the tip of the probe regularly. JM recommends patching all t-joints — to include base flashing — using a 7" (17.78 cm) rounded piece of reinforced field membrane or JM TPO T-Joint Patch.

Test all welded seams for integrity and continuity before the end of each work day. In addition to probing, take seam samples to verify seam quality as necessary.



Cut the samples across the seam 6" (15.24 cm) on each side of the seam and 2" (5.08 cm) wide. Peel these samples by hand to test seam strength. Good seams will be virtually impossible to peel and should delaminate the JM TPO film from the reinforcing scrim. Cut and test a minimum of three seam samples each day — in the morning, at noon and at day's end. Take additional test cuts when weather conditions change or after work interruptions when the automatic hot air welder has been shut off.

Sealing Seams

Seal all cut seam edges with JM TPO Edge Sealant after testing and repairing. This prevents water from entering the welded area through wicking or capillary action. Weld and seal seams at all cut edges on the same day. Clean and dry any edges that stand overnight to ensure good sealant adhesion. Apply sealant with a squeeze bottle. Draw the tip smoothly along the cut edge of the membrane to produce a uniform $\frac{1}{8}$ " (3.18 mm) bead.



JM TPO-Coated Metal

JM TPO-Coated Metal is a special flashing material used to fasten some JM TPO Membranes at roof edges (perimeters), walls, decks and around penetrations. It is supplied in large, galvanized sheets with JM TPO Non-Reinforced Membrane material laminated to one side. The roof membrane is welded to this surface. The other side is galvanized metal.



JM TPO-Coated Metal Flashing is formed off site by the roofing contractor, to the shapes required for attaching the membrane. Prefabricating numerous perimeter flashing sections in the same shape is easily and accurately done in the sheet metal shop. Prefabrication reduces installation time. Special parts such as scuppers, however, are formed on the job to match the opening size and save time.

JM Fasteners and Plates

Use appropriate fasteners and plates on mechanically fastened roofs to fasten the membrane and/or insulation to the roof deck. Special screws and fasteners simplify attachment of roof layers to wood, steel, concrete, lightweight or other decks.



The most common method of installing a JM TPO mechanically fastened roofing system is the in-lap method, where the membrane overlap covers and protects the installed fasteners.

JM High Load and Extra High Load Fasteners and Plates are used to attach the roof system to steel and wood decks. Special fasteners are used for lightweight insulating concrete and concrete decks.

JM supplies many fasteners for mechanically fastened roofs. There are several key rules to follow when installing a mechanically fastened roof:

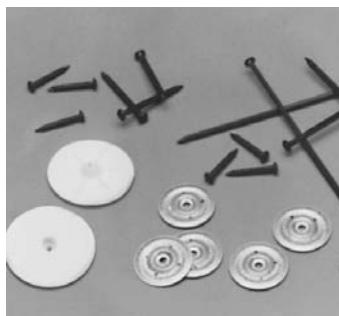

1. Use appropriate fastener type for substrate.
2. Securely anchor fasteners to roof deck.
3. Flatly seat and secure plates on substrate.
4. Do not tighten fastener/plate assembly excessively, which causes depression of insulation.
5. Achieve minimum thread penetration of ¾" (1.91 cm) through metal decks, 1" (2.54 cm) into wood decks and 1" (2.54 cm) into concrete decks with special spikes. Plywood and OSB decks require a minimum of ¼" (6.35 mm) penetration through the bottom of the deck.
6. Fasteners must go through the top flange on metal decks.

Membrane Adhesives

JM TPO Membrane Adhesives (Solvent-Based and Water-Based)

JM TPO Membrane Adhesive (Solvent-Based) is designed for bonding JM TPO Membrane to metal, wood, concrete and certain roof insulations and should be used to adhere wall flashings or other vertical surfaces. The solvent-based adhesive is easily spread, has good initial tack and dries to an elastomeric bond.

JM TPO Membrane Adhesive (Water-Based) is a water-based, polymeric, low-VOC adhesive for bonding JM TPO Membrane to horizontal surfaces. This product conforms to many air quality and VOC requirements and has excellent tack and green strength.

JM TPO Membrane Adhesive (Low VOC) is a synthetic, rubber-based, two-sided, low-VOC adhesive for bonding JM TPO Membrane to horizontal and vertical surfaces. This product conforms to many air quality and VOC requirements.

For additional product-specific information, refer to the JM TPO Membrane Adhesive data sheets for solvent-based and water-based products.

Section 3 – Installing Mechanically Fastened and Fully Adhered Roof Systems

This section describes the procedures and materials used to install mechanically fastened and fully adhered JM TPO roofs. Included are: flashing installation, membrane installation, membrane fastening procedures for mechanically fastened roofs and adhering roof membranes.

Installation Preparation

Nailers

After properly preparing the roof deck, install wood nailers when required. Place nailers on the perimeter of the roof, along the top of parapet walls and, where required, around roof penetrations and along roof expansion joints. Set the height of the nailers flush with the roof insulation.

Space fasteners for wood nailers a maximum of 24" (60.96 cm) o.c. with at least three fasteners per nailer, depending on nailer length. Each fastener must resist a minimum pull-out force of 200 lb/ft (298 kg/m) in any direction.

JM TPO-Coated Metal Flashings are fastened to wood nailers. When using membrane flashings, fasten the field sheet to the deck with a fastener/plate system as shown in Detail TB-25.

JM TPO-Coated Metal Flashing

Preformed JM TPO-Coated Metal Flashing is fastened around the roof perimeter (edge and base flashings) and roof penetrations. Welding the membrane to JM TPO-Coated Metal Flashings at these points provides a watertight seal.



JM TPO-Coated Metal Flashing is manufactured in 10' (3.05 m) lengths. Leave a ¾" to ½" (9.53 mm to 1.27 cm) maximum gap between each length to allow for thermal expansion. Aluminum tape should be applied over all joints in JM TPO-Coated Metal prior to heat welding the joint covers and membrane in place. JM TPO-Coated Metal Flashing can be used as an asphalt separator in lieu of plywood or galvanized metal.

The following are instructions for installing JM TPO-Coated Metal base flashing, wall fastening strips and gravel stops.

Base Flashing with JM TPO-Coated Metal

Set the base flashing width along the horizontal roof surface (flange) at least 3½" (8.89 cm) to allow for welding and caulking with JM TPO Edge Sealant. Flashing must extend a minimum of 8" (20.32 cm) up vertical wall surfaces.

Fasten base flashing to nailers per the job specifications, but as a minimum, using galvanized roofing nails, spaced a maximum of 6" (15.24 cm) o.c. to resist a minimum pull-out force of 200 lb/ft (298 kg/m). Nail heads should be at least ⅜" (9.53 mm) in diameter, penetrating into the nailer at least ¾" (1.91 cm).

You may fasten JM TPO-Coated Metal base flashing directly to the parapet wall under some conditions. Consult job specifications. Fasteners must provide a minimum pull-out force of 200 lb/ft (298 kg/m), placed at a maximum height of 2" (5.08 cm) above the top surface of the JM TPO Membrane.

Fasten JM TPO-Coated Metal base flashing to concrete with concrete fasteners. Space fasteners per the job specifications, but not greater than 12" (30.48 cm) o.c. and drive at least 1" (2.54 cm) into concrete to obtain the required pullout strength. JM TPO-Coated Metal base flashing can also be fastened to hollow block (cinder block) walls with the appropriate fasteners. Consult JM for more details.

JM TPO-Coated Metal Flashing can be used as an asphalt separator in lieu of plywood or galvanized metal.

Wall Flashing with JM TPO-Coated Metal

JM TPO-Coated Metal base flashing serves as a roof termination on roofs with low parapet walls. A metal coping overlaps the JM TPO-Coated Metal base flashing and serves as a counterflashing on walls which are 8" (20.32 cm) or less.

Higher walls are sealed with JM TPO Membrane Flashing. See "Membrane Flashing" section for application of fully adhered and mechanically attached flashings.

Gravel Stops

The top of the gravel stop must be at least 1½" (3.81 cm) above the nailer height. This may vary, depending on roof conditions. The bottom edge of the flashing should extend at least 1" (2.54 cm) below the nailer on the vertical fascia surface.



If the vertical gravel stop face exceeds 4" (10.16 cm), fasten per the job specifications, but not less than a 20-gauge to 24-gauge (0.91 mm to 0.61 mm), continuous galvanized steel clip on the fascia.

Fasten continuous steel cleats per the job specifications, but not less than two roofing nails, between flashing lengths. This provides a rigid support for the gravel stop and helps align the section. Use lengths of gravel stop to quickly position each cleat. Fasten the gravel stop to the wood nailer with roofing nails spaced 6" (15.24 cm) o.c. and staggered. Leave a ⅜" to ½" (9.53 mm to 1.27 cm) gap for expansion between gravel stop lengths. Apply aluminum tape to the joint prior to heat welding the joint covers and membrane in place.

Membrane Flashings

Install all membrane flashings at the same time as the roof membrane. Do not use temporary flashings. If water penetrates the flashings, immediately replace all affected materials.



Use only JM TPO fully adhered or mechanically attached flashings or prefabricated flashings, depending on job circumstances. Secure the mechanically attached flashings to the parapet wall at a maximum vertical distance of 18" (45.72 cm) o.c., and horizontally to the parapet at maximum spacing of 12" (30.48 cm) o.c. Secure adhered flashings to the parapet wall at 36" (91.44 cm) vertical intervals. All adhered surfaces must be compatible with JM TPO roofing membranes. If existing asphalt flashing remains, then 1½/32" (1.19 cm) thick plywood, ¼" (1.43 cm) OSB, 26-gauge (0.45 mm) galvanized metal (if using adhered flashings), or 9 oz./yd² (0.31 kg/m²) polyester fleece must be secured to the asphaltic surface as a barrier before applying JM TPO Membrane Flashings. **Paper slip-sheets are not acceptable for use as asphalt barriers.** Apply adhesive as noted in Section 3, "Fully Adhered Systems." **Do not apply adhesive to any flashing areas that will be welded.**

Extend all flashings a minimum of 8" (20.32 cm) above the roof level. Contact the JM Roofing Services Group for recommendations if this cannot be done. Terminate all JM TPO Membrane Flashings per the applicable detail.

Roof Substrate Materials

Vapor Retarders

Vapor retarders prevent moisture or condensation from entering the building, or passing from the building into the roof system. To provide an effective shield against water vapor, seal off all vapor retarders at roof edges and penetrations.

Air Barriers

Air barriers should be considered on jobs where high internal air pressure exists, such as airport hangars or distribution warehouses with many outside openings (such as loading docks), outdoor amphitheaters, etc.

Insulation

Insulation must be independently fastened to the roof deck in mechanically attached and adhered systems. Adhering certain insulations in hot asphalt or cold adhesives is sometimes acceptable for adhered systems. For specific requirements, contact the JM Roofing Services Group.

Always cut insulation to fit closely around all roof penetrations. Around drains, taper insulation a minimum of 36" x 36" (91.44 cm x 91.44 cm) for proper drainage.

Apply rigid insulation directly over fluted steel decks to provide smooth, continuous membrane support. Insulation should be installed with long edges parallel to the direction of the deck and supported by the deck flange. When butting insulation layers, do not allow the edge of either board to overlap an open flute. Cut the insulation so the edge of the board is about at the center of, and supported by, the top flange.

Slipsheets

A slipsheet is often used under the membrane on mechanically fastened roofs. It provides a smooth surface over which the membrane can freely expand or contract when temperature variations cause changes in the roof structure.

The slipsheet is loosely laid and usually overlapped, depending on the slipsheet selected. It should be neatly cut to fit closely against roof edges and around penetrations. An approved slipsheet must be used between the JM TPO Membrane and any polystyrene insulation product.

Coal Tar Pitch

Coal tar pitch roofs give off noxious fumes and vapors which can affect JM TPO roofing membranes. You must separate coal tar pitch roofs from the JM TPO Membrane in the following manner:

- Place insulation with a minimum R-value of 10.0 (hr•ft²•°F)/Btu [1.76 m²•°C/W] and a minimum thickness of 1½" (3.81 cm) over the existing roof, with the joints of the insulation butted together at all four sides.

Installing Membranes

Unroll the JM TPO Membrane and position without stretching. Allow the membrane to relax for at least 15 minutes when the temperature is above 60°F (16°C), or 30 minutes when the temperature is below 60°F (16°C) prior to installation. Inspect for any damaged membrane. Remove sections of the membrane that are creased or damaged.

Install all roof deck materials (vapor retarders, insulation and slipsheets) in complete sections, and cover with the membrane immediately to produce weathertight sections each day.

Phased construction is not permitted.

For mechanically attached systems on steel decks, the membrane sheets must be applied perpendicular to the ribs (flutes) of the deck. This method offers two advantages. First, most roofs are pitched to drain along the roof's length. Many roofs drain from each end to the middle. In this case, the installation is started at the wall edge, and the membrane is welded and sealed immediately against water infiltration. It also requires less work to seal the shorter edge of the roof with a water cutoff at the end of the work day. And you will save money by removing and discarding less cut-off material.

Welding Membranes to Roof Edges

The JM TPO-Coated Metal Edge is installed and is stripped into the field sheet with a detail strip.

Mechanically Fastened Systems

To prevent wind uplift and secure the membrane on mechanically attached roofs, fasten the membrane to the roof deck with metal plates and acceptable fasteners.

Corners and Perimeters

Refer to the local code requirements, project specifications or FM Global® requirements when determining fastener rates. The requirements to calculate perimeter areas are as follows:

1. 40% of the height or 10% of the lesser plan dimension, whichever is less (minimum 3' [91.44 cm]).
2. For mechanically fastened systems, only perimeter rolls may be used in these areas. The width of the perimeter rolls should be no greater than 60% of the width of the field sheets in the perimeters, and no greater than 40% of the width in the corners.

Corner Areas

All corners shall be the intersections of the perimeter areas. Refer to the local code requirements, project specifications or FM Global requirements when determining corner layouts for perimeter sheets. Typically, one of the following layouts is used in the corners:

1. The perimeter rolls should be fastened all the way into the corner. The other perimeter sheets are fastened up to the previously installed perimeter sheets, and then the fastener rows are continued to the corner through the top of the previously installed sheets. Install a cover strip of reinforced membrane extending 2" (5.08 cm) on each side over the fasteners for a watertight seal.
2. The perimeter rolls should be run perpendicular to the flutes in steel deck applications. Additional fasteners should be installed in rows that are no greater than 40% of the width of the field sheets. These fastener rows should then be stripped in with reinforced JM TPO Membrane.

Section 2 describes the plates and methods used to mechanically fasten JM TPO roofs. Following are step-by-step procedures for in-lap fastening.

The In-Lap Method

1. Roll out one roll of membrane over the slipsheet (if required) or acceptable insulation board. Let it relax 15 to 30 minutes or as needed to compensate for any residual roll tension.



2. Secure the plate along the edge of the membrane, maintaining at least a ½" (1.27 cm) distance from the edge of the plate to the outer edge of the roll. Fastener and plate spacing is per FM Global requirements and/or job specifications.
3. Tightly screw down the plates (do not overdrive the fastener) using an appropriate screw gun unit with adjustable torque clutch. Make certain to drive the fastener perpendicular to the surface of the substrate and to properly penetrate the deck surface. On steel decks, the screws must be fastened into the top flanges of the deck.
4. After securing the edge of the first membrane roll, unroll the next adjacent roll of membrane. Position this roll so that its common edge fully overlaps the row of plates and fasteners just installed. Maintain a minimum overlap of 6" (15.24 cm) (depending on plate size) to cover the plates, and leave the required 1½" (3.81 cm) minimum for the seam weld.
5. Weld the overlap seam. Apply a bead of liquid JM TPO Edge Sealant along all cut edges of the overlap.

Fully Adhered Systems

All membranes and substrates to be adhered must be approved by Johns Manville. Both surfaces must be clean, smooth, dry, compatible and free of contaminants and grease/oil. All fasteners, if required, must be properly seated and plates flush, leaving an acceptable surface to receive adhesive.

Unroll the membrane and allow it to relax at least 15 minutes before applying adhesive, longer time is necessary in colder weather.

Position the membrane with a 2" (5.08 cm) overlap between sheets. Fold membrane back one-half of the length of the first sheet's length to expose its bottom side.

Make sure adhesive container is sealed. Turn upside down and wait a minimum of five minutes. Turn container right-side up. Carefully open and vigorously stir until adhesive is a uniform color and all solids are dispersed, with NO SWIRLS.

Saturate roller by dipping into can. Roll adhesive onto substrate and membrane for smooth-backed membrane, and substrate only for fleece-backed membrane.

For solvent-based adhesives, the appearance of a spider web effect will occur with stringers off the roller when the roller needs to be redipped into the adhesive. It will also be hard to push the roller.

Follow directions in this section for specific adhesive and membrane type (i.e., smooth-backed or fleece-backed) as directed for proper applications.



JM TPO Installation Guide

When adhesive is ready, carefully roll the membrane into the substrate, avoiding wrinkles. Apply even pressure with a lawn or linoleum roller (minimum 75 lb [34 kg]) to ensure good contact between the membrane and substrate.

Do not apply adhesive in the seam area; seams are to remain clean and dry. Avoid puddling of adhesive. With adhesives, more is not necessarily better. "Over-coating" adhesives will lead to poor adhesion.

Do not use in direct contact with polystyrene foam.

Adhesive coverage, open time and dry time rates can vary dramatically depending on the particular substrate and environmental conditions. Coverage rate charts, stated herein, are approximate only. If FM Global or UL® approval is required, please consult the specific RoofNavSM or UL certification directory for specific application rates.

Substrate for Adhered Membrane							
	Lightweight Concrete	Concrete	Invinsa®	SECUROCK® Gypsum Fiber Roof Board	Wood Fiber	ENERGY 3®	DensDeck®
JM TPO	N/A	N/A	WB/SB	WB/SB	P/A	WB/SB	WB/SB
JM TPO Fleece-Backed	WB	WB	WB	WB	P/A	WB	WB

Key:

WB - Water-Based
 SB - Solvent-Based
 N/A - Not Applicable
 P/A - Pre-Approval Required

Notes:

- Water-Based Adhesive: Use the two-sided contact application method for all smooth-backed single ply membranes. **Use the one-sided application method for fleece-backed membranes only.**
- DensDeck: Priming of the board is required.
- Not suitable for SECUROCK Glass-Mat roof boards.
- Do not use solvent or low-VOC solvent with fleece-backed membrane.

Solvent and Low-VOC/Solvent-Based, Two-Sided Application for Plain-Backed (Smooth-Backed) Membrane

Apply solvent-based adhesive in a smooth, even, thin coat to both membrane and approved substrate at the rates listed on specific product data sheets. Most applications apply approximately half the listed rate to the membrane and the other half to the substrate. For porous substrates such as wood and gypsum, apply more adhesive on the substrate.

Do not allow adhesive on both sides to dry completely; if no longer tacky it cannot be used. TPO systems require adhesive to become tacky to the touch on both surfaces without stringers. Time will vary depending on the ambient temperature and humidity.

Water-Based, Two-Sided Application for Plain-Backed (Smooth-Backed) Membranes Only

Apply water-based adhesive in a smooth, even, thin coat to both the membrane and approved substrate at the rates listed on specific product data sheets. Most applications apply approximately half the listed rate to the membrane and the other half to the substrate. For porous substrates such as wood and gypsum, apply more adhesive on the substrate.

Adhesive should be tacky at point of assembly, approximate time will vary depending on the environmental conditions. Once the adhesive begins to change color (from white to clear) and feels tacky, but with no stringers (as with the solvent adhesive), carefully roll the membrane to the substrate. Avoid capturing air or creating wrinkles during this process. If adhesive is completely dry or too wet (still all white), adhesion will be compromised.

Water-Based, One-Sided Application for Fleece-Backed Membranes Only

For fleece-backed membrane ONLY, apply the full rate of water-based adhesive to the substrate ONLY. Do not apply adhesive to the membrane. DO NOT apply to the fleece-backed membrane or in the weld area; keep both surfaces clean and dry. Assemble membrane and substrate while adhesive on the substrate is still wet.

Water-Based Adhesives Cautions

- Water-based adhesives are white; if product appears to have disappeared after application, then adhesive is too dry and will need to be reapplied.
- Do not over apply. Use the coverage rate chart in this section; too much adhesive will result in curing issues.
- Prior to application and curing, water-based adhesive can NEVER be exposed or stored to temperatures below 40°F. Do not apply when ambient temperatures are expected to drop below 40°F within 48 hours after application.

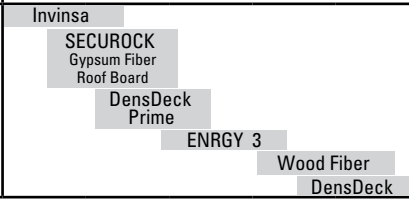
Suggested Coverage Rate Ranges					
	Ft ² /gal (gal/sq)				
Solvent-Based or Low-VOC/Solvent-Based	90 (1.11)	80 (1.25)	70 (1.43)	60 (1.67)	50 (2.0)
Water-Based	130 (0.77)	120 (0.83)	110 (0.91)	100 (1.0)	90 (1.11)
	← Less Adhesive More Adhesive →				
Insulation and Cover Boards					
Notes:					
<ul style="list-style-type: none"> Listed rates are for finished roofing areas. See JM requirements for correct application method. Two-Sided Application: Most applications apply approximately half the listed rate to the membrane and the other half to the substrate. For porous substrates such as wood and gypsum, apply more adhesive on the substrate. One-Sided Application: Apply the full amount to the substrate only. If the rate is 1.0 gal/sq, the full gallon goes on the substrate only. 					

Walkways

If pavers are used as permanent walkways for maintenance of rooftop equipment, use an additional layer of JM TPO Membrane or a layer of JM Polyester Mat Protection Material under paver blocks to protect the membrane.



Another walkway option on a mechanically fastened or adhered roof is to weld strips of JM TPO Walkpad material directly to the membrane. See detail TM-93 and note that walkpads should not be installed over field seams. This material provides an almost continuous walkway, and is embossed for a skid-resistant surface. It also minimizes the effects of added weight on roofs. JM TPO Walkpad should be continuously welded to the membrane and checked for voids, which must be repaired with a hot air welder. Continuously welding the walkpad material will seal against grit or water entry. Fully adhered systems require walkpads to also be fully adhered.

Water Cutoffs

Sensitive materials such as insulation or slipsheets can be damaged or destroyed by water. Apply water cutoffs to seal the edge of roofing layers at the end of the work day.



If a cutoff is required on an existing gravel-surfaced roof, completely spud off the gravel for a watertight connection.

If JM TPO Membrane has been exposed for a period greater than 24 hours and/or compromised by dirt or debris, the area shall be cleaned with JM Single Ply Membrane Cleaner prior to welding to ensure full weld strength.

Section 4 – Roof Penetrations

This section describes procedures for fabricating, installing and welding typical roof penetrations to the membrane. Included are: drains, vent pipes and penetration pockets.

Weld membranes to flashings around roof penetrations and to base flashings as a continuous, waterproof roofing shield. Install nailers where required around penetrations for flashing support.

Drains

There are several methods for flashing drains with JM TPO Roofing Membrane. The most common method is to taper insulation to the drain bowl. Next, run slipsheet (if required) over insulation to edge of drain bowl interior.

Apply one tube of JM Single Ply Sealing Mastic around the drain bowl. Cut JM TPO Flashing Membrane to overlay drain area, and cut out hole in center area 2" (5.08 cm) smaller than metal drain bowl diameter. Cut holes one-half the size of bolt diameter at drain bolt penetrations. Make sure there are no seams or fasteners through the drain clamping ring. Ideally, there should be no seams or fasteners in the drain sump.

Carefully press membrane drain flashing over drain bowl area and work into the caulk to form seal. Place metal clamping ring over membrane flashing so that bolt holes line up, and then tighten the bolts (see detail TF-55).

Vent Pipes

There are two primary methods for installing vent pipes in JM TPO roofing systems:

Method A. Sealing Pipe Base With JM TPO Flashing (TF-51)

Prepare a square JM TPO Detail Membrane stretch collar to overlap the securement plate edges by at least 4" (10.16 cm), to accommodate sheet movement and a 1½" (3.81 cm) weld width. Round off all corners. Cut a hole in the center of the membrane that is about two-thirds of the diameter of the pipe. Center hole over the pipe, heat area around the hole with a heat welder, and stretch fit membrane over the pipe to create a 1" (2.54 cm) turn-up, with the collar seated flush on the deck.

Weld the membrane collar continuously to the field sheet and/or the metal collar. Field wrap JM TPO Detail Membrane around the pipe stand and adhere to the vent pipe, while flanging the bottom of the field wrap. Extend field wrap flange at least 1" (2.54 cm) onto the membrane stretch collar and weld continuously to the collar. If the pipe has asphalt or other contaminants on it, it must be cleaned and wrapped completely with aluminum tape before installing the flashing.

Method B. Installing Prefabricated Vent Pipe Boots (See Details TF-50S, TF-ST)

JM TPO Pipe Boots are available to accommodate various diameters for installation over pipes. They are available with a peel-and-stick adhesive or in a heat-weldable style.

Prior to pipe boot installation, remove any asphaltic deposits from vent pipes. Completely wrap any remaining asphalt with aluminum tape before plastic boot comes into contact with pipe. Bring the JM TPO field sheet up to the base of the pipe and fasten or secure with a minimum of four fasteners around the vent stack. If using the peel-and-stick pipe boot, first prime the field area, then place the boot over the pipe and remove the peel-and-stick tape. If using the prefabricated pipe boot, place the boot over the pipe and weld continuously around the bottom lip of the boot. Ensure that pipe boot extends past outside edge of all fasteners by a minimum 1½" (3.81 cm).

Apply JM Single Ply Caulk behind the top of the pipe boot membrane before pulling draw band tight around the vent pipe. Also apply it to the top of the draw band to seal against water intrusion.

Penetration Pockets

JM Penetration Pockets are two-piece molded pockets with a rigid vertical wall and preformed flange. Field-fabricated penetration pockets are also available, typically fabricated from JM TPO-Coated Metal.

Leave an open, overlapped seam at the center of one side so the penetration pocket may be spread around penetrations before final riveting. Minimum penetration pocket height is 4" (10.16 cm).

Fasten penetration pocket flanges at the outside to the deck or nailer. The overlap or opening must be covered with aluminum tape and detail membrane prior to stripping flange. With strips of JM TPO Detail Membrane, strip in penetration pocket around all four sides, and weld continuously to JM TPO-Coated Metal as you would a field sheet. Seal all cut edges with JM TPO Edge Sealant.

Using JM TPO Pourable Sealer, fill until mounded above penetration pocket and slope from pipe to penetration pocket edges to shed water (no ponding water should be present in penetration pocket). Fasten penetration pockets greater than 18" x 18" (45.72 cm x 45.72 cm) to nailers securely anchored to the deck.

Prefabricated penetration pockets follow the same procedure, except that the plastic flange is fastened to the deck before being stripped in. Since you can weld the plastic penetration pocket to the strip of membrane, continuously weld the strip to the flange and the field sheet.

Section 5 – Flashing Installation Machine Hot Air Welding

Step 1

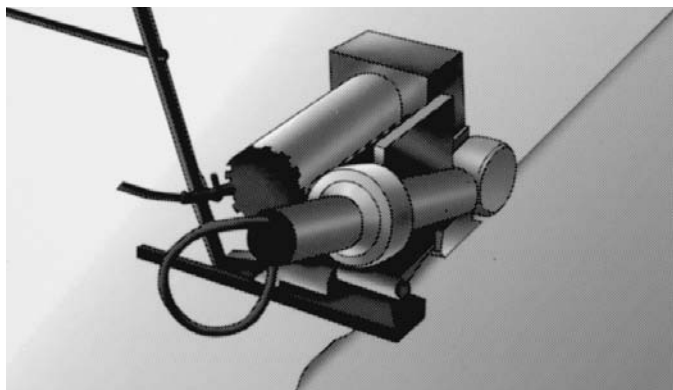

- Set the heat and speed setting on the automatic welding machine based on field conditions and air temperature. Make certain that proper power supply is available.
- Align the welding machine with the edge of the membrane seam lap as required, and insert the nozzle fully into the weld zone. Minimum weld width should be 1½" (3.81 cm).
- Raise the back wheel to allow the machine to ride on its two drive wheels.
- Adjust the heat and speed setting on the automatic welding machine as required.
- To steer the machine along the seam, place the small guide wheel (located at the front of the machine) against the seam's edge. Adjust and maintain the wheel against the seam's edge as required.
- The drive wheel and welder tip align and extend ⅛" (3.18 mm) beyond the edge of the seam so there are no loose edges of membrane.

JM TPO Membrane Base Flashing

Outside Corner

Step 1

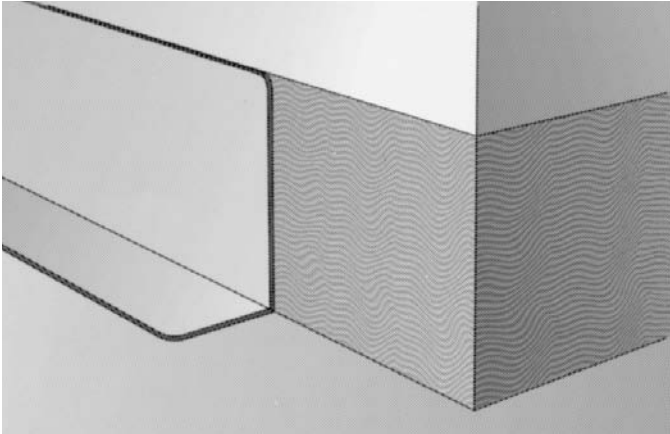

- Cut JM TPO Detail Membrane and extend vertically 8" (20.32 cm) minimum, or use an 18" (20.32 cm) curb flashing, leaving enough membrane at the flashing base to overlap fasteners/plates and to provide for a 1½" (3.81 cm) minimum continuous weld. Apply adhesive to both membrane and substrate as required. See "Fully Adhered Systems" section in the appropriate guide specification.

Step 2

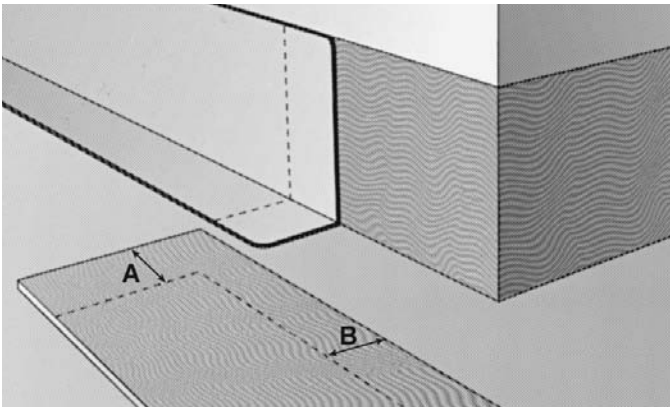

- Overlap the successive layer of membrane flashing 2" (5.08 cm) minimum over the previously installed sheet. Provide the minimum base overlap as required.

Step 3

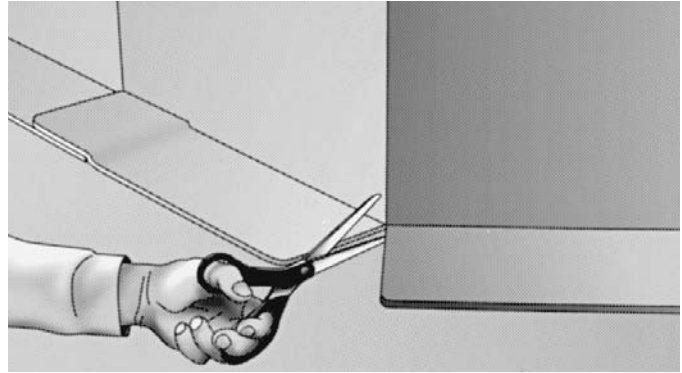

- Form membrane to wall as required. The JM TPO Membrane Flashing must extend a minimum of 12" (30.48 cm) horizontally in each direction from the corner point.
- Cut the membrane flashing base lap to allow the membrane flashing to turn the corner.
- Install fasteners at corners where required by system details.

Step 4

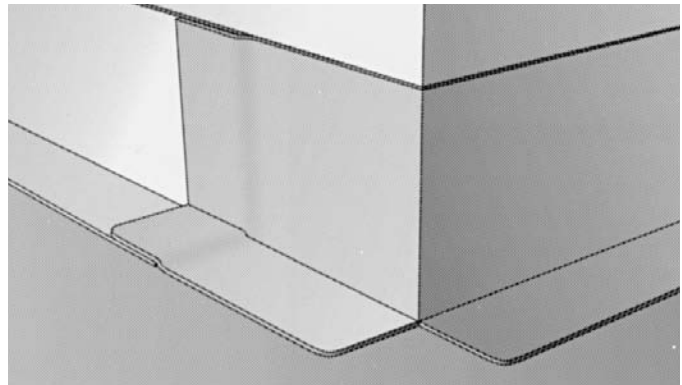

- Turn the corner and apply the membrane flashing as required.
- Round the corners of the membrane base overlap on each side of the corner and at all ends of the flashing base overlap.

Step 5

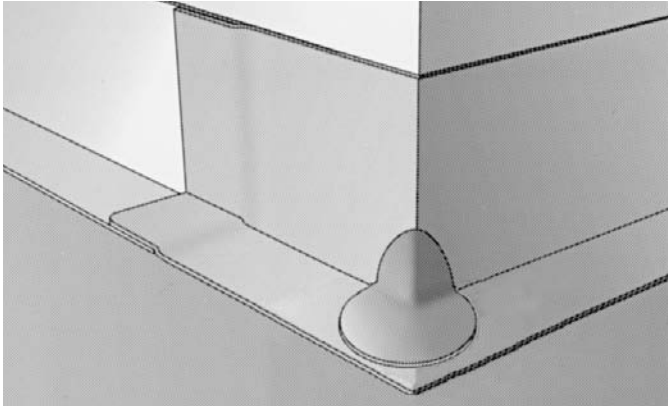

- Install a JM TPO Universal Corner welded to the flashing sheet with a continuous 1" (2.54 cm) minimum heat weld. Care must be taken to leave an unwelded area at the center of the corner to allow for movement.
- Probe and check all seams.

JM TPO Membrane Base Flashing Universal Corner Step 1

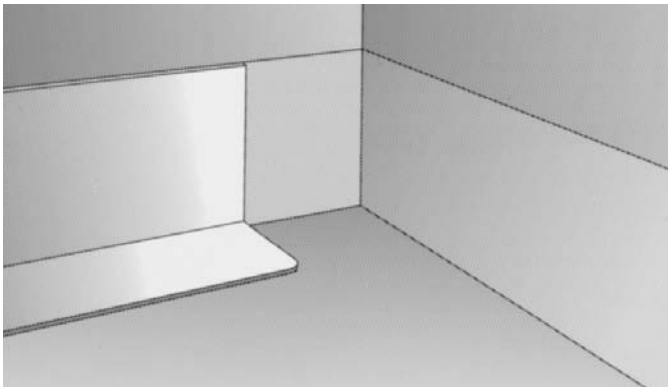

- Cut JM TPO Membrane to extend vertically 8" (20.32 cm) minimum, or use an 18" (20.32 cm) curb flashing, leaving enough membrane at the flashing base to overlap fasteners/plates and to provide for a 1½" (3.81 cm) minimum continuous weld. Apply adhesive to both membrane and substrate as required. See "Fully Adhered Systems" section in the appropriate guide specification.

Step 2

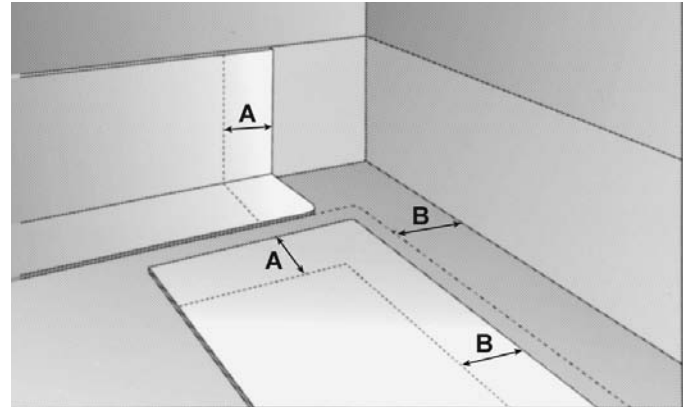

- Overlap the successive layer of membrane flashing 2" (5.08 cm) minimum over the previously installed sheet. Provide the minimum base overlap as required.

Step 3

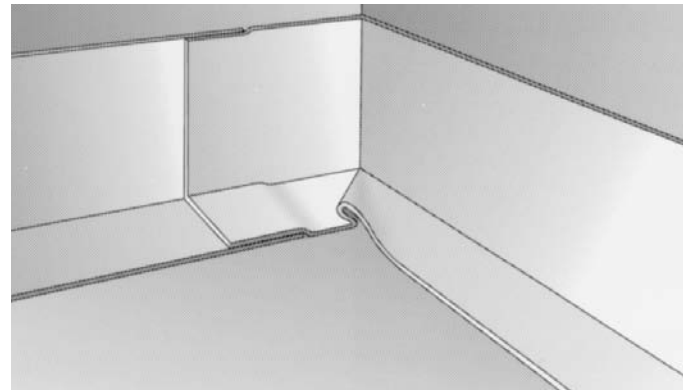

- Form membrane to wall as required. The JM TPO Membrane Flashing must extend a minimum of 12" (30.48 cm) horizontally in each direction from the corner point.
- Fold over the membrane flashing base lap (forming a "pig's ear") to allow the membrane flashing to turn the corner.
- Turn the corner and apply the membrane flashing as required.

Step 4

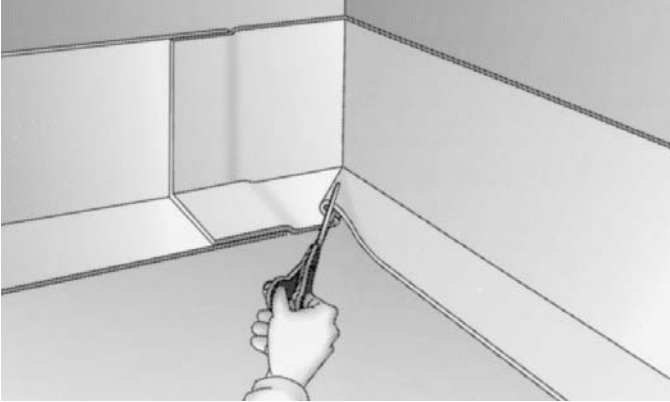

- Using a pair of shears, make a diagonal cut in the “pig’s ear,” forming an overlap.
- Round the corners of the membrane base overlap on each side of the corner and at all ends of the flashing base overlap.

Step 5

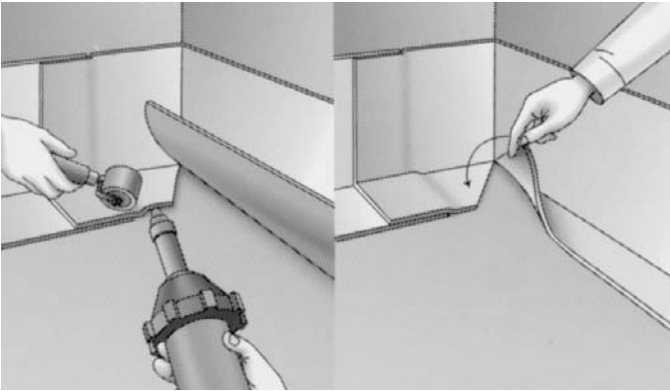

- Using a hand-held hot air welder and roller, heat weld the bottom flap of the “pig’s ear” to the field membrane and the top flap over the bottom flap.

Step 6

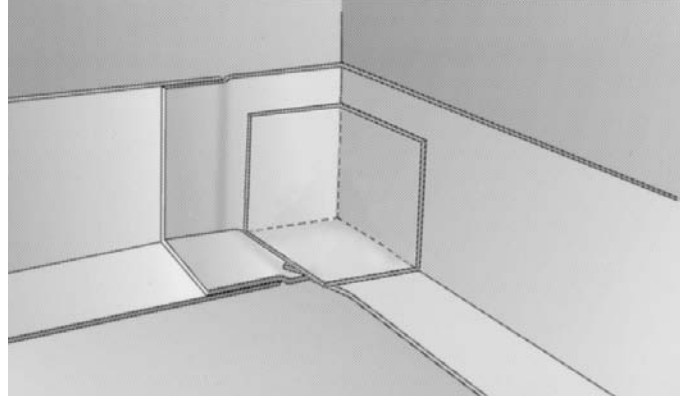

- Install a JM TPO Universal Corner (image not shown) welded to the flashing sheet membrane with a continuous 1" (2.54 cm) minimum heat weld. Care must be taken to leave an unwelded area at the center of the corner to allow for movement. Reference flashing detail TF-63.
- Probe and check all seams.

JM TPO Membrane Curb Flashing Step 1

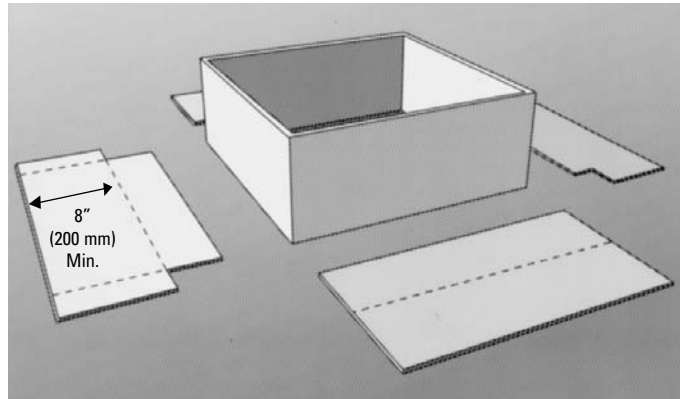

- Cut JM TPO Membrane to extend vertically 8" (20.32 cm) minimum, or use an 18" (20.32 cm) curb flashing, leaving enough membrane at the flashing base to overlap fasteners/plates and to provide for a 1½" (3.81 cm) minimum continuous weld. Apply adhesive to both membrane and substrate as required. See “Fully Adhered Systems” section in the appropriate guide specification.

Step 2

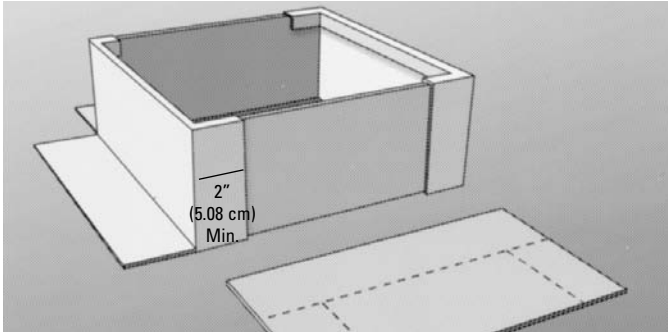

- Overlap the successive layer of membrane flashing 2" (5.08 cm) minimum over the previously installed sheet. The JM TPO Membrane Flashing must overlap a minimum of 2" (5.08 cm) from the corner point as shown. Provide the minimum base overlap as required.

Step 3

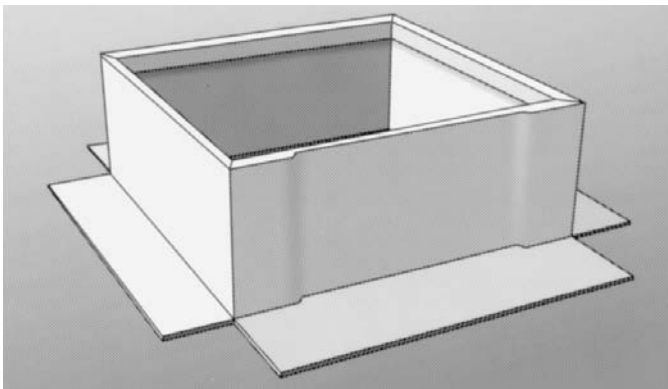

- Form membrane to curb as required.

Step 4

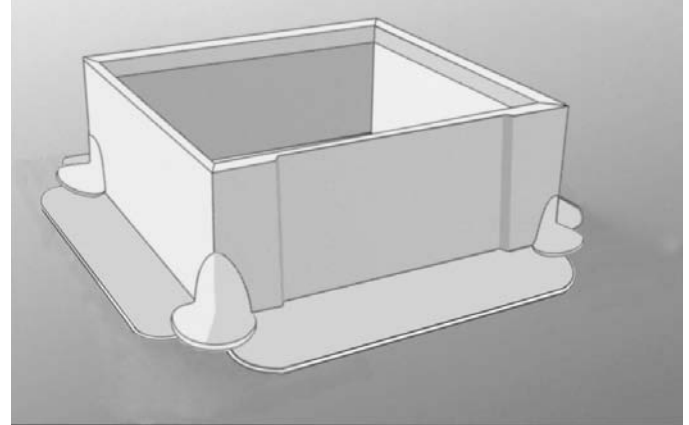

- Round the corners of the membrane base overlap on each side of the corner and at all ends of the flashing base overlap.

For each corner:

- Install a JM TPO Universal Corner to the flashing sheet with a continuous 1" (2.54 cm) minimum heat weld. Care must be taken to leave an unwelded area at the center of the corner to allow for movement.
- Probe and check all seams.

JM TPO Membrane Canted Base Curb Flashing

Step 1

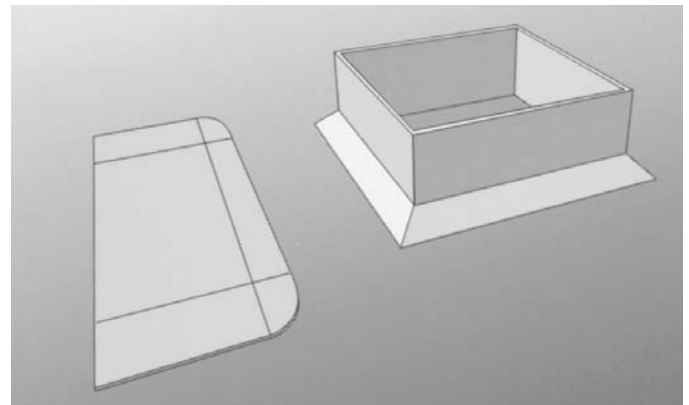

On two opposite sides of the curb:

- Install JM TPO Membrane base flashing extending vertically 8" (20.32 cm) minimum, leaving enough membrane at the flashing base to overlap fasteners/plates and to provide for a 1½" (3.81 cm) minimum continuous weld. Apply adhesive to both membrane and substrate as required. See "Fully Adhered Systems" section in the appropriate guide specification.
- Cut JM TPO Membrane base flashing as required to conform to the canted curb base.

Step 2

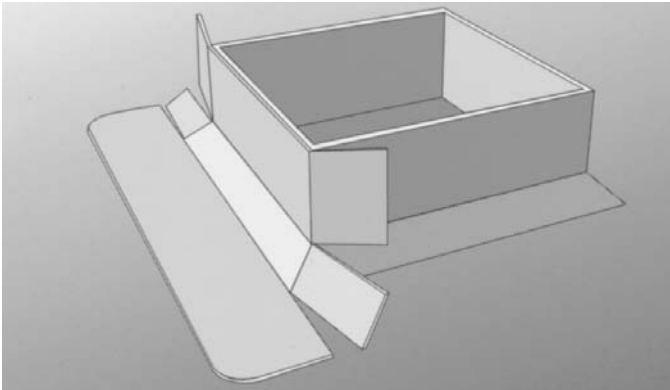

- Overlap the successive layer of membrane flashing 2" (5.08 cm) minimum over the previously installed sheet. Provide the minimum base overlap as required.

Step 3

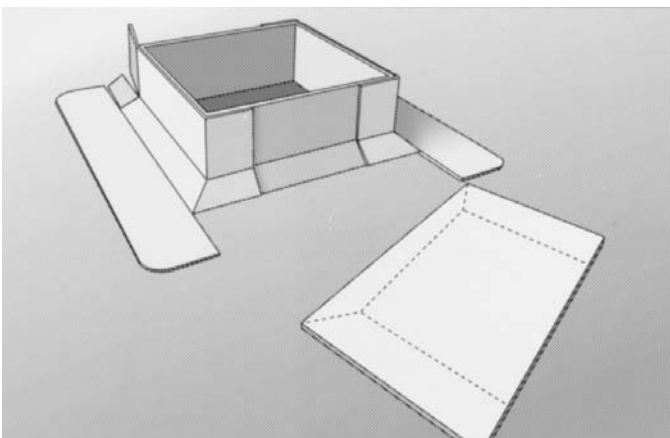

- Form membrane to curb as required. The JM TPO Membrane Flashing must overlap a minimum of 2" (5.08 cm) from the corner point.

On remaining two sides of the curb:

- Cut JM TPO Membrane base flashing as required to conform to the canted curb base with mitered corners at the base overlap.
- Form membrane to curb as required.

Step 4

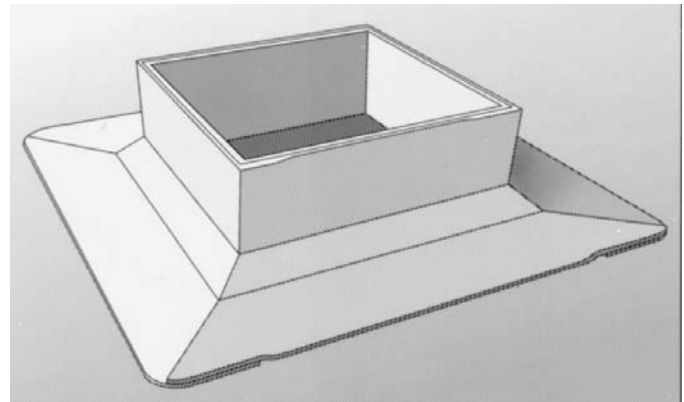

- Round the corners of the membrane base overlap on each side of the corner and at all ends of the flashing base overlap. Apply JM TPO Edge Sealant to all cut edges.

Step 5

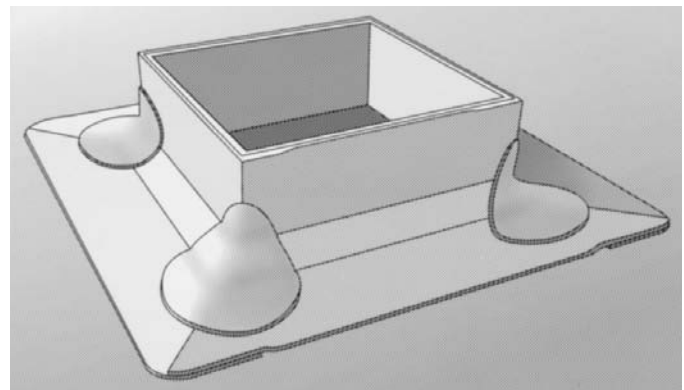

For each corner:

- Install a JM TPO Universal Corner welded to the membrane base flashing with a continuous 1" (2.54 cm) minimum heat weld. Care must be taken to leave an unwelded area at the center of the corner to allow for movement. Note: The JM TPO Universal Corner may not work on all canted curbs. Some curbs may need to be flashed with JM TPO Detail Membrane.
- Probe and check all seams.

JM TPO-Coated Metal Curb Flashing

Step 1

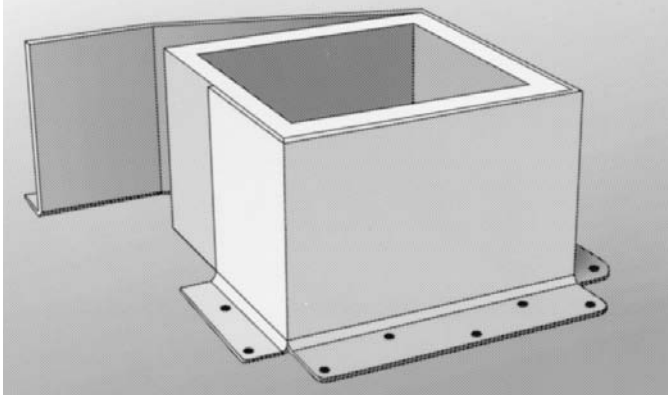

- Measure, cut and bend JM TPO-Coated Metal Flashing to the dimensions of the roof penetration. The JM TPO-Coated Metal should be cut at the base flashing to allow a 90 degree bend around each corner.

Step 2

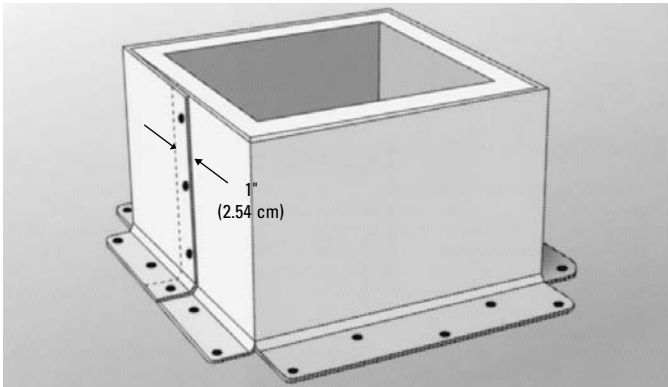

- Overlap the butt ends of all JM TPO-Coated Metal Flashing a minimum of 1" (2.54 cm) and fasten along the vertical joint as required.
- Fasten JM TPO-Coated Metal Flashing to deck with approved fasteners. Nailers may also be used.

Step 3

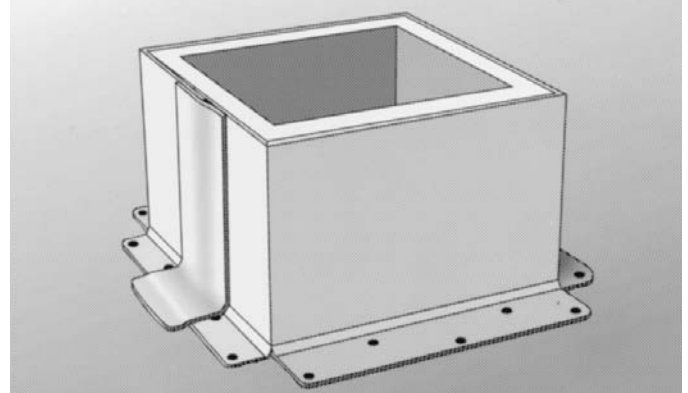

- Install a 2" (5.08 cm) wide strip of aluminum tape over the JM TPO-Coated Metal Joint.
- Cut JM TPO Detail Strip long enough to cover the entire length of the JM TPO-Coated Metal Joint and extend beyond the edge of the 3½" (8.89 cm) deck flange onto the roof deck.
- Center the JM TPO Detail Strip over the joint to allow a 1½" (3.81 cm) minimum continuous weld on each side of the joint.
- Using a hand-held hot air welder and roller, begin welding the strip in place as shown.

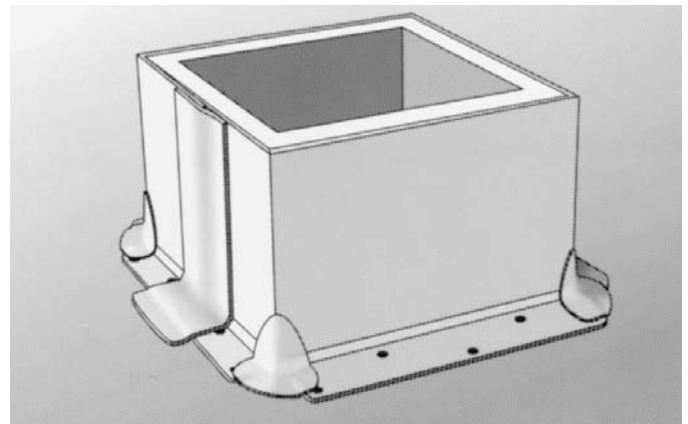

Step 4

Install JM TPO Universal Corners, welded to the JM TPO-Coated Metal Flashing with a continuous 1" (2.54 cm) minimum heat weld. Care must be taken to leave an unwelded area at the center of the corner to allow for movement.

- Alternately, JM TPO Universal Corners may be installed after the field membrane has been installed.

Step 5

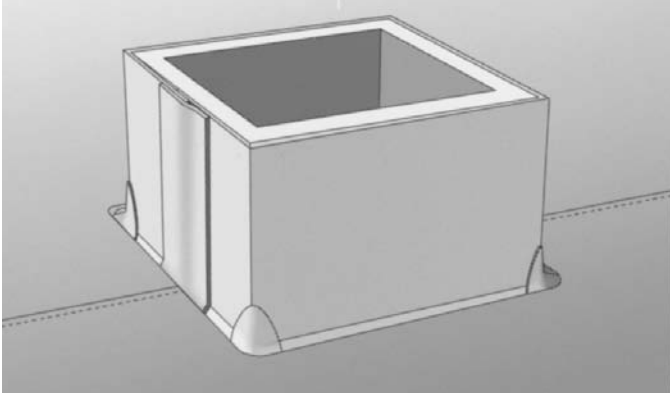

- Roll out the slipsheet (if required) and field membrane as required, butting the slipsheet (if required) tightly to the JM TPO-Coated Metal Flange. Alternately, the slipsheet should be installed underneath all flanges to prevent movement.
- Align the edge of the field membrane, covering and extending beyond all fastener heads 1½" (3.81 cm) minimum, but do not extend onto cant.
- Using a hand-held hot air welder and roller, weld the field sheet to the JM TPO-Coated Metal Deck Flange to form a watertight seal.
- Probe and check all seams.

JM TPO-Coated Metal Penetration Pocket Flashing

Step 1

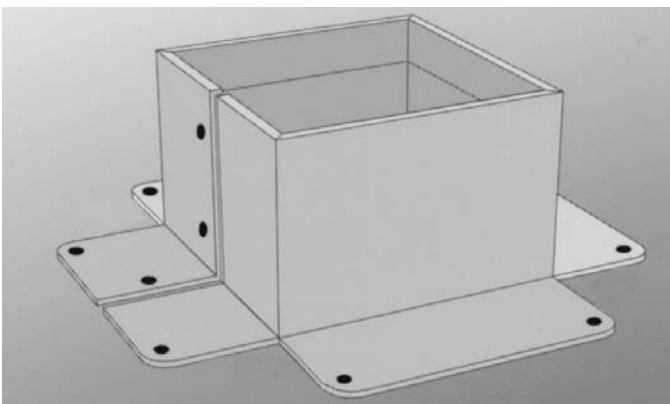

- Measure, cut and bend JM TPO-Coated Metal Flashing to a minimum of 1" (2.54 cm) larger than the dimensions of the roof penetration. The metal should be cut at the base flange to allow a 90 degree bend around each corner.
- Overlap the butt ends of all JM TPO-Coated Metal Flashing a minimum of 1" (2.54 cm), and fasten along the vertical joint as required.
- Fasten JM TPO-Coated Metal Flashing to deck with approved fastener. **Note: If penetration pocket exceeds 18" (45.72 cm), a nailer must be provided.**

Step 2

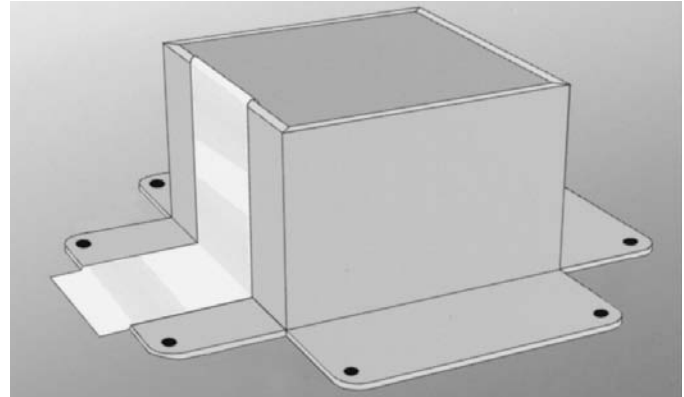

- Install a 2" (5.08 cm) wide strip of aluminum tape over the JM TPO-Coated Metal Joint.
- Cut JM TPO Detail Strip long enough to cover the entire length of the JM TPO-Coated Metal Joint and extend beyond the edge of the 3½" (8.89 cm) deck flange onto the roof deck and inside the top of the penetration pocket.
- Center the JM TPO Detail Strip over the joint to allow a 1½" (3.81 cm) minimum continuous weld on each side of the joint.
- Using a hand-held hot air welder and roller, begin welding the strip from the outside face of the JM TPO-Coated Metal, and continue until the strip has been completely welded.

Step 3

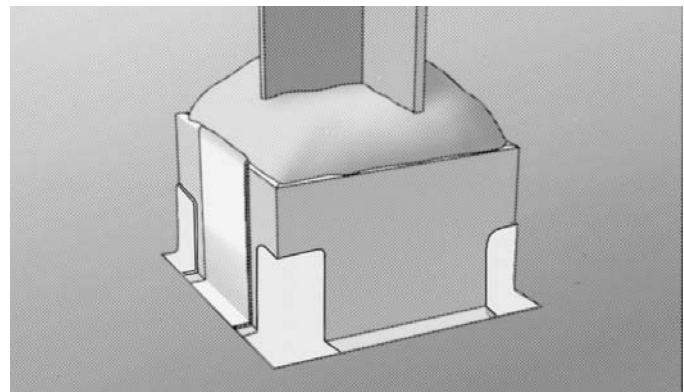

- Install JM TPO Universal Corners (reinforced or nonreinforced per the job specifications) at all corner locations, welded to the JM TPO-Coated Metal Flashing with a continuous 1" (2.54 cm) minimum heat weld. Care must be taken to leave an unwelded area at the center of the corner to allow for movement.
- Alternately, JM TPO Universal Corners may be installed after the field membrane has been installed.

- Roll out the slipsheet (if required) and field membrane, butting the slipsheet (if required) tightly to the JM TPO-Coated Metal Flange.
- Align the edge of the field membrane, covering and extending beyond all fastener heads $1\frac{1}{2}$ " (3.81 cm) minimum.
- Using a hand-held hot air welder and roller, weld the field sheet to the JM TPO-Coated Metal Flange to form a water-tight seal. **Note: At the 90-degree bend, care should be taken to ensure that the weld is adequate without scorching or bridging.**
- Probe and check all seams.
- Fill the penetration pocket with JM TPO Pourable Sealer rounded to prohibit ponding water.
- After probing and checking all seams, apply JM TPO Edge Sealant to all cut edges.

JM TPO-Coated Metal Edge Flashing

Step 1

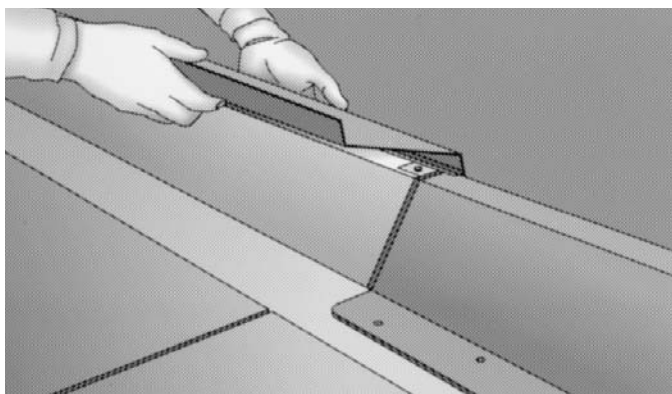

- Hook return bend of preformed JM TPO-Coated Metal Flashing onto edge of continuous cleat (when required) and set the JM TPO-Coated Metal Flashing in place with a minimum $3\frac{1}{2}$ " (8.89 cm) nailing flange flush with top of nailer.
- Allow a $\frac{3}{8}$ " to $\frac{1}{2}$ " (9.53 mm to 1.27 cm) gap for thermal expansion between metal sections.

Step 2

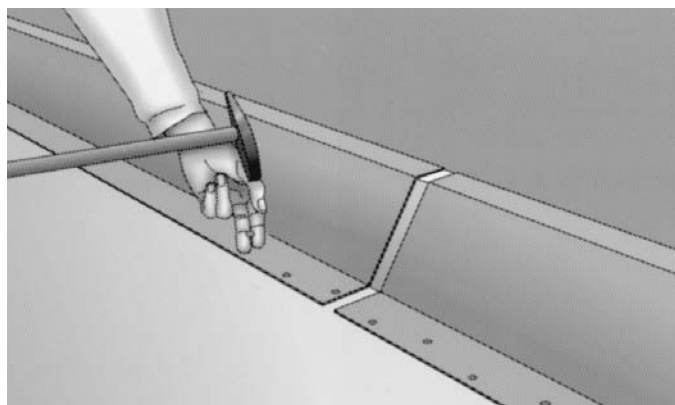

- Fasten JM TPO-Coated Metal Flashing to nailer per job specifications, but not less than 6" (15.24 cm) o.c., staggered 1" (2.54 cm) with galvanized roofing nails or an acceptable fastener. Fastener heads should be a minimum of $\frac{3}{8}$ " (9.52 mm) in diameter and penetrate the nailer $1\frac{1}{4}$ " (3.18 cm) minimum.

Step 3

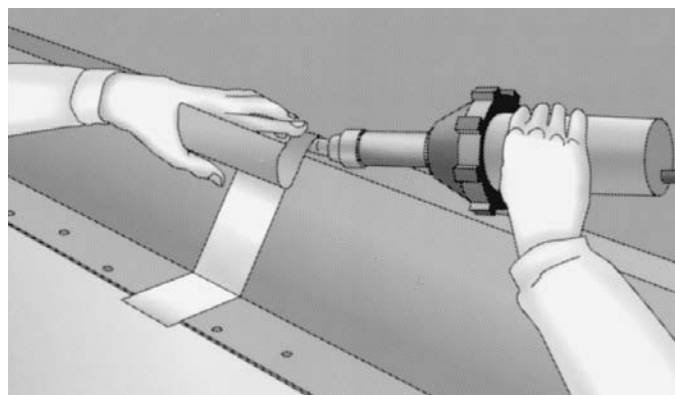

- Install a 2" (5.08 cm) wide strip of aluminum tape covering the entire length of the JM TPO-Coated Metal Joint. Extend the tape onto the deck a minimum of 1" (2.54 cm).
- Cut JM TPO Detail Strip long enough to cover the entire length of the JM TPO-Coated Metal Joint and extend beyond the edge of the $3\frac{1}{2}$ " (8.89 cm) deck flange onto the roof deck.
- Center the JM TPO Detail Strip over the joint to allow a $1\frac{1}{2}$ " (3.81 cm) minimum continuous weld on each side of the joint.
- Using a hand-held hot air welder and roller, begin welding the strip from the outside face of the JM TPO-Coated Metal, and continue until the strip has been completely welded from outside to inside on each side of the joint. Care should be taken to tightly weld break areas.

Step 4

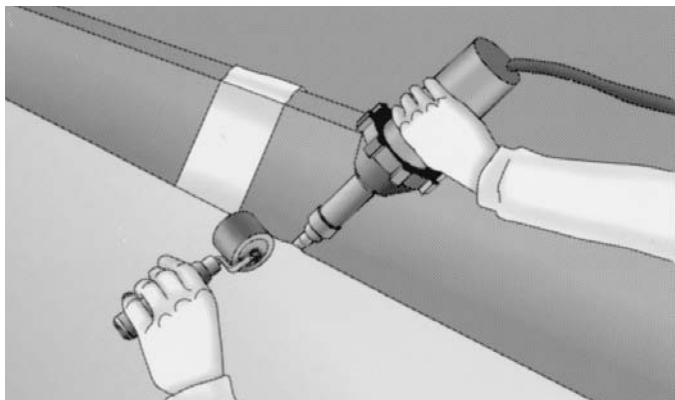

- Roll out the slipsheet (if required) and field membrane, butting the slipsheet (if required) tightly to the JM TPO-Coated Metal Flange. The slipsheet will roll, curl or move under the membrane if left loose with no fasteners close by. Loose insulation moves under a mechanically fastened roof and the same thing happens with slipsheets.
- Align the edge of the field membrane, covering and extending beyond all fastener heads 1½" (3.81 cm) minimum.
- Using a hand-held hot air welder and roller, weld the field sheet to the preformed JM TPO-Coated Metal Deck Flange to form a watertight seal.

Step 5

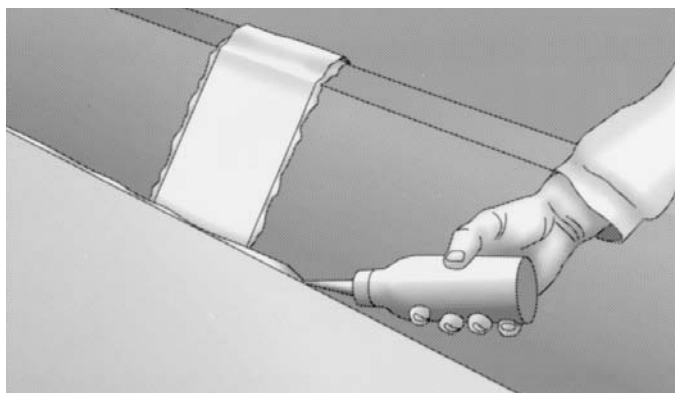

- Seal all seam edges with JM TPO Edge Sealant.
- Apply sealant with a squeeze bottle. Draw the tip smoothly along the cut edge of the membrane to produce a uniform 1/8" (3.18 mm) bead.
- Probe and check all seams.

Vent Pipe Flashing Step 1

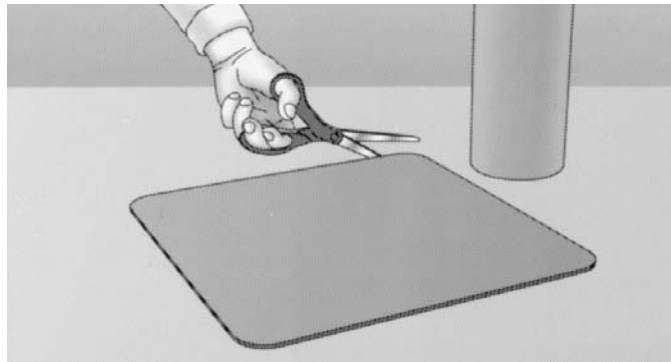

- Prepare a square JM TPO Detail Membrane Stretch Collar with all corners rounded. The stretch collar should be large enough to extend a minimum of 4" (10.16 cm) beyond fasteners and plates when used.

Step 2

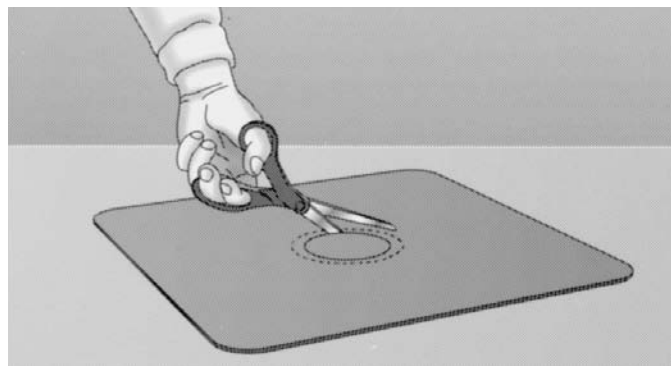

- Mark the pipe diameter at the center of the membrane stretch collar.
- Cut a round hole in the stretch collar approximately two-thirds of the pipe diameter.

Step 3

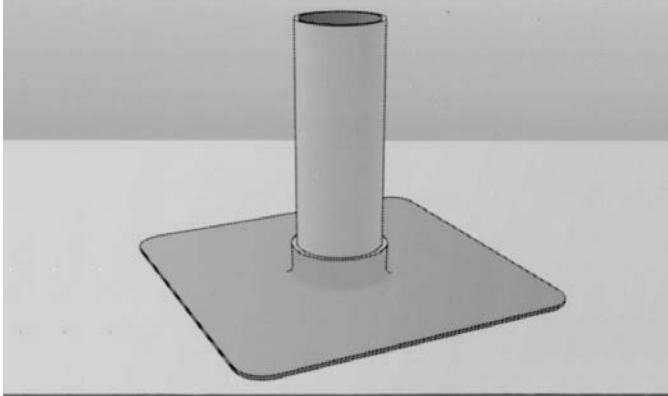

- Using a hand-held hot air welder, heat the area around the stretch collar hole, and stretch fit membrane over the pipe to create a 1" (2.54 cm) turn-up with the collar seated flush on the field membrane.
- Weld the collar continuously to the field sheet.

Step 4

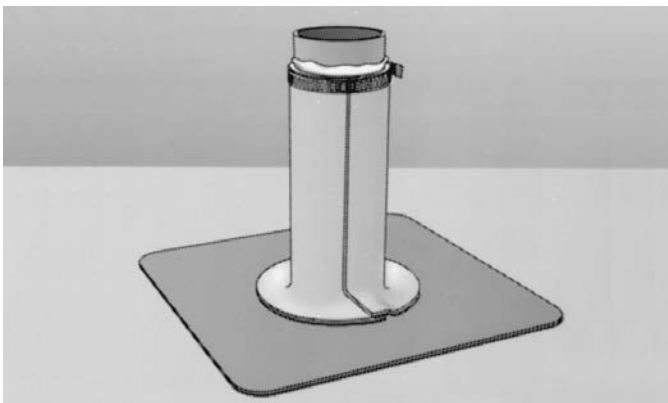

- Field wrap and adhere a piece of JM TPO Detail Membrane to the pipe while flaring the bottom of the field wrap membrane.
- Extend the field wrap flange a minimum of 1" (2.54 cm) onto the membrane stretch collar and weld continuously.
- Overlap and weld the vertical edge of the field wrap membrane.
- Apply JM TPO Edge Sealant to all cut edges.
- Apply JM Single Ply Caulk behind and around the top of the field wrap membrane.
- Install and tighten a draw band at the top of the field wrap membrane to seal against water intrusion.

Note: Pipe boots should be installed on all round penetrations whenever possible. Field flashing should be completed when it is impossible to install a pipe boot.

Drain Flashing

Step 1

- Set or adjust drain bowl elevation as required.
- Install tapered insulation around drain bowl, forming a tapered sump area at least 36" x 36" (91.44 cm x 91.44 cm). The tapered sump area should not exceed 4:12 slope.
- Install roof insulation butted tightly to the tapered insulation at the drain sump and adjacent insulation.

Step 2

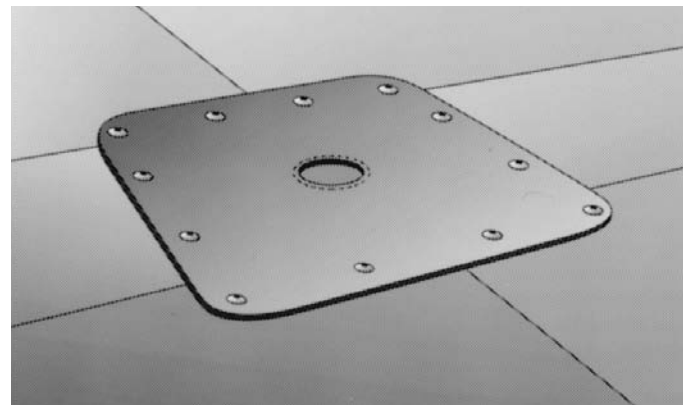

- Prepare the drain sump liner as required for the application in accordance with standard practice. For re-roofing, use JM TPO Detail Membrane after cleaning contaminated areas. The drain sump liner should be a minimum of 12" (30.48 cm) larger around than the sumped area.
- Round all corners of the membrane sump liner.
- Mark and cut a circular hole from the center of the membrane drain sump liner approximately 2" (5.08 cm) smaller than the drain bowl diameter.
- Mark and cut small circular holes for the clamping ring mounting bolts.
- Center the clamping ring over the sump liner hole, and form the flashing to fit the tapered sump area.
- Remove the clamping ring, and fasten the membrane drain sump liner along the outside edges at 12" (30.48 cm) o.c.

Step 3



- Apply JM Single Ply Mastic to entire drain bowl flange.

Step 4

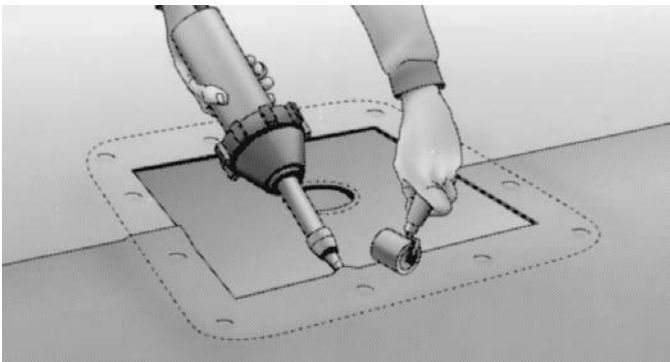

- Install the membrane over the drain. Make sure there are no seams or fasteners in the clamping ring area. Ideally, there should be no fasteners or seams in the drain sump.
- Cut the field membrane to overlap the drain sump liner fasteners a minimum of 4" (10.16 cm) all around.
- Heat weld the roof membrane to the membrane drain sump liner with a minimum of a 1½" (3.81 cm) continuous weld that is completely watertight.

Step 5

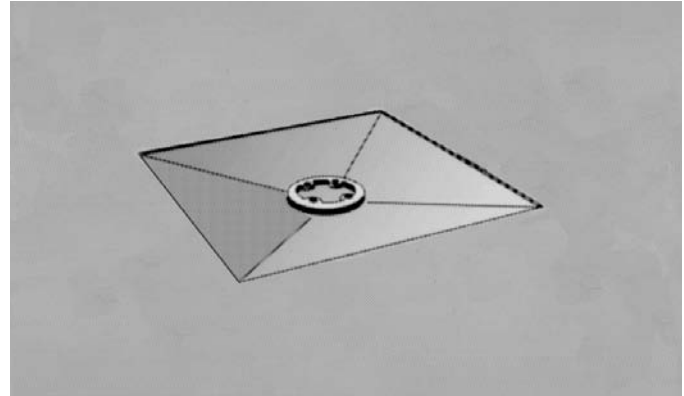

- Press the membrane drain sump liner into the JM Single Ply Caulk to form a watertight seal.
- Install the drain clamping ring and all four mounting bolts over the precut holes and tighten as required.

Step 6

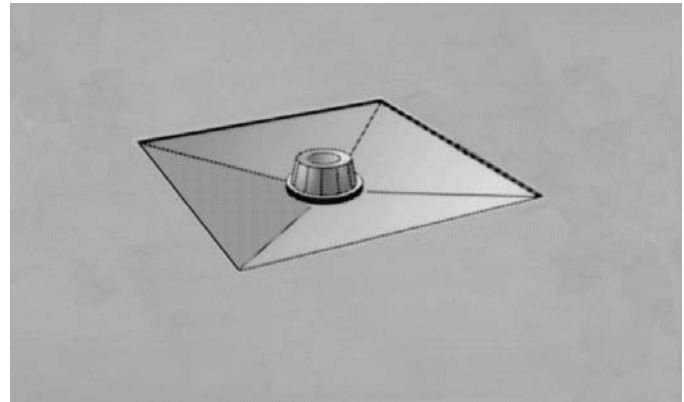

- Install drain strainer basket on clamping ring.
- Apply JM TPO Edge Sealant to all cut membrane edges.

Membrane Repair

Step 1

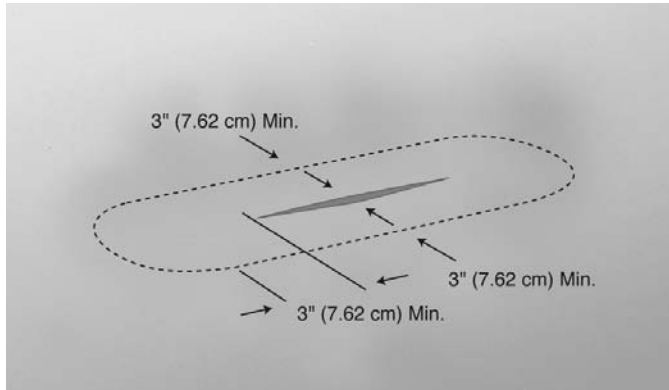

- Cut a rectangular piece of JM TPO Membrane, the same type as the field membrane, a minimum of 3" (7.62 cm) larger in all directions of the repair area. The membrane patch must provide a 1½" (3.81 cm) minimum continuous weld around all edges.
- Round all corners of the rectangular membrane patch.

Step 2

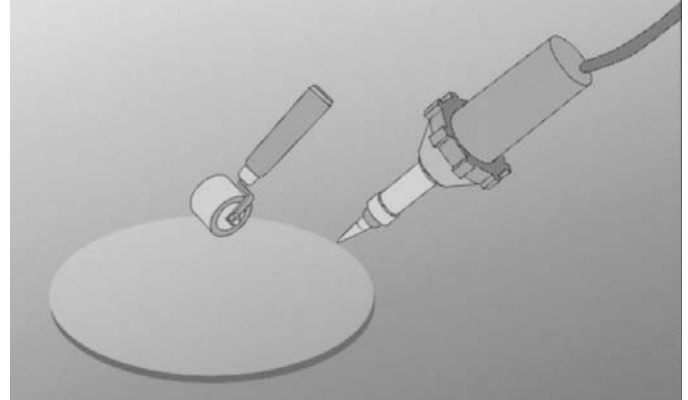

- Clean and remove all dirt and contaminants from the surface of the field membrane in the repair area using JM Single Ply Membrane Cleaner.
- Center the membrane patch over the repair area, and heat weld the membrane patch to the field membrane using a hand-held hot air welder and roller. Be sure to provide a 1½" (3.81 cm) minimum continuous weld around all sides of the patch.
- Check and probe the weld at the membrane patch, and apply JM TPO Edge Sealant to all cut edges.