

RONDO ACCESSORIES

SUMMARY

Rondo has a range of accessories to complement our steel wall and ceiling systems, which includes Top Hats, Reveal Beads and Angles, as well as a rod bending tool for suspended ceiling applications.

SUITABLE FOR:

Top Hats:

- internal and external applications
- higher wind loading areas or with heavy duty sheeting
- vertical fascias and soffits

Heavy Duty Steel Angles:

- Autoclaved Aerated Concrete Panel Systems (AAC) and steel framing requirements for façade systems.

Reveal Beads:

- window openings

Speedpanel Channel & Angle:

- 78mm Speedpanel systems

Rod Bender:

- Rondo 121 Plain Rod and 122 Threaded One End Rod

SPECIAL FEATURES

- Wide variety of Top Hat profiles to suit most external and internal applications and can be installed either vertically or horizontally
- Top Hats and Heavy Duty Angles are manufactured from G200 Z275 Galvanised Steel
- Heavy Duty Angles are available in 0.75 & 1.15bmt steel thicknesses
- Reveal Beads are cold rolled from 0.9mm Zincanneal steel for strength
- Reveal Beads are UV-resistant to withstand harsh UV rays without cracking or breaking down
- Speedpanel Channel and Angles are made from G2 Z275 Galvabond Steel and available in 1.15bmt (1.2mm TCT) steel thickness
- Rondo Rod Bender can bend up to 3 rods at one time to the required 30° angle for suspended ceiling applications

IN PRACTICE

Many components in the Rondo accessory range have been used in leading projects to complement other Rondo wall and ceiling systems, including the use of Top Hats in the new *Queensland Children's Hospital* project.

IMPORTANT NOTE:

Rondo recommends its products and systems are installed by a qualified tradesperson and according to the relevant codes and standards outlined on page [256](#) of this manual.

CONTENTS:

ACCESSORIES [224](#)

TOP HATS

• INSTALLATION [225](#)

• FASTENERS [227](#)

• SECTION DIMENSIONS [229](#)

• SERVICEABILITY LIMIT STATE LOAD TABLES [230](#)

• ULTIMATE LIMIT STATE LOAD TABLES [240](#)

REVEAL BEADS [250](#)

ANGLES [251](#)

SPEEDPANEL [252](#)

ROD BENDER [253](#)

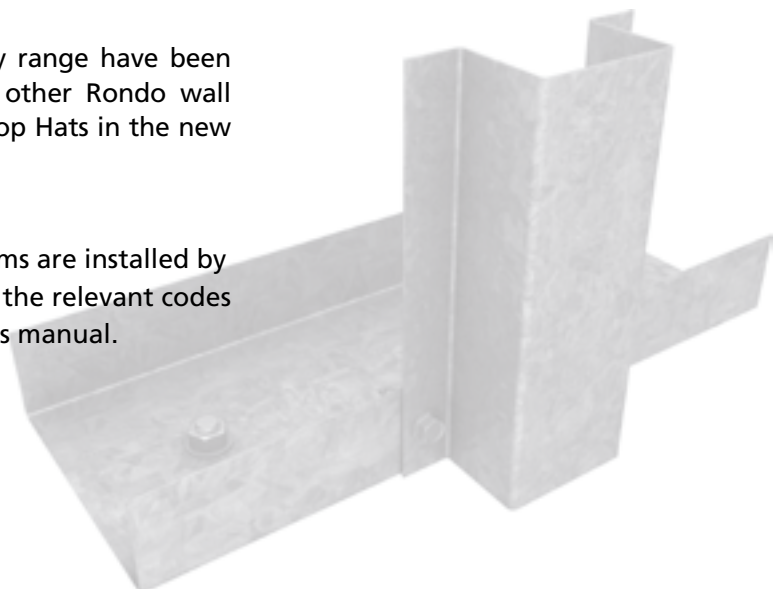

ACCESSORIES

MEDIUM WEIGHT TOP HATS

| | |
|------|----------------------------------|
| M515 | 15 x 15 x 50 x 15 x 15 x 0.75bmt |
| M525 | 20 x 25 x 50 x 25 x 20 x 0.75bmt |
| M535 | 20 x 35 x 50 x 35 x 20 x 0.75bmt |
| M545 | 20 x 45 x 50 x 45 x 20 x 0.75bmt |
| M550 | 20 x 50 x 50 x 50 x 20 x 0.75bmt |
| M560 | 20 x 60 x 50 x 60 x 20 x 0.75bmt |
| M715 | 15 x 15 x 75 x 15 x 15 x 0.75bmt |
| M725 | 20 x 25 x 75 x 25 x 20 x 0.75bmt |
| M735 | 20 x 35 x 75 x 35 x 20 x 0.75bmt |
| M750 | 20 x 50 x 75 x 50 x 20 x 0.75bmt |

HEAVY WEIGHT TOP HATS

| | |
|------|----------------------------------|
| H515 | 15 x 15 x 50 x 15 x 15 x 1.15bmt |
| H525 | 20 x 25 x 50 x 25 x 20 x 1.15bmt |
| H535 | 20 x 35 x 50 x 35 x 20 x 1.15bmt |
| H545 | 20 x 45 x 50 x 45 x 20 x 1.15bmt |
| H550 | 20 x 50 x 50 x 50 x 20 x 1.15bmt |
| H560 | 20 x 60 x 50 x 60 x 20 x 1.15bmt |
| H715 | 15 x 15 x 75 x 15 x 15 x 1.15bmt |
| H725 | 20 x 25 x 75 x 25 x 20 x 1.15bmt |
| H735 | 20 x 35 x 75 x 35 x 20 x 1.15bmt |
| H750 | 20 x 50 x 75 x 50 x 20 x 1.15bmt |

TOP HAT CLEATS

| | |
|-----|------------------------|
| 550 | 50 x 55 x 1.9bmt Cleat |
| 535 | 50 x 35 x 1.9bmt Cleat |
| 750 | 75 x 55 x 1.9bmt Cleat |
| 735 | 75 x 35 x 1.9bmt Cleat |

REVEAL BEADS

| | |
|---------|-------------------|
| REVB020 | 20mm Reveal Bead |
| REVB025 | 25mm Reveal Bead |
| REVB035 | 35mm Reveal Bead |
| REVB050 | 50mm Reveal Bead |
| REVB060 | 60mm Reveal Bead |
| REVB065 | 65mm Reveal Bead |
| REVB075 | 75mm Reveal Bead |
| REVB080 | 80mm Reveal Bead |
| REVB090 | 90mm Reveal Bead |
| REVB100 | 100mm Reveal Bead |
| REVB110 | 110mm Reveal Bead |
| REVB120 | 120mm Reveal Bead |
| REVB150 | 150mm Reveal Bead |

ANGLES

| | |
|------|----------------------------------|
| 552 | 25 x 25 x 0.70bmt Angle |
| 553 | 35 x 35 x 0.70bmt Angle |
| 554 | 50 x 50 x 0.70bmt Angle |
| HB50 | 50 x 50 x 0.80 Slotted Angle |
| HB75 | 75 x 50 x 1.15 Slotted H/D Angle |
| 555 | 75 x 75 x 0.75 H/D Angle |
| 556 | 75 x 75 x 1.15bmt H/D Angle |
| 557 | 100 x 100 x 0.75bmt H/D Angle |
| 558 | 100 x 100 x 1.15bmt H/D Angle |

SPEEDPANEL

| | |
|-----|--|
| 559 | 50 x 50 x 1.15bmt Speedpanel 'C' Angle |
| 820 | 82 x 51 x 1.15bmt Speedpanel 'C' Channel |

ROD BENDER

| | |
|-----|------------|
| 130 | Rod Bender |
|-----|------------|

TOP HATS



MEDIUM/HEAVY

TOP HAT CLEATS



550

535

750

735

REVEAL BEADS



REVB

ANGLES

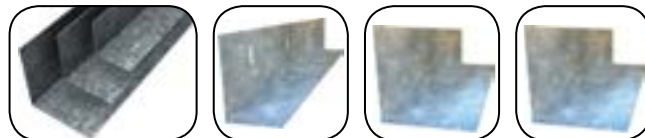

552/553/554

HB50/HB75

555/556

557/558

SPEEDPANEL

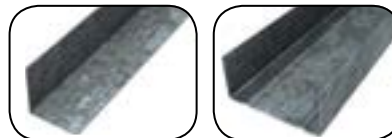

559

820

ROD BENDER



130

TOP HATS

Installation

Rondo produces a wide range of standard “off the shelf” Top Hat profiles for a variety of uses both internally and externally, including applications where there is a higher wind loading or where heavy duty sheeting is to be installed. Rondo also produces a range of complementary adjustable fixing cleats.

The Rondo Fixing Cleats enable adjustable fixing of Top Hats to steel or masonry/concrete substrates as well to steel stud framing, providing adjustment for plumb and level of the cleat to the structure and of the Top Hat onto the cleat as shown in Figures 1, 2 and 3.

The cleats are available to suit both 50 and 75mm width Top Hats and in two depths of 35 and 55mm.

These products are available in 0.75bmt (Medium) and 1.15bmt (Heavy) gauges in two different face widths, 50 and 75mm and four different depths, 15, 25, 35 and 50mm. Rondo Top Hats are manufactured from G200 Z275 Gal steel.

The product codes and details are referenced in the accompanying Ultimate and Serviceability Limit State Load Tables.

INSTALLATION TO CONCRETE OR STEELWORK

Top Hats can be fixed vertically or horizontally to suit the installer’s requirements, either screw fixed directly to a supporting substrate or fixed with the Rondo cleats (see Figures 1 & 2).

1



■ TOP HAT FIXED TO STEELWORK
FIXINGS: CLEAT TO STEELWORK AND TOP HAT TO CLEAT WITH #12 TEK SCREWS AS SHOWN

2

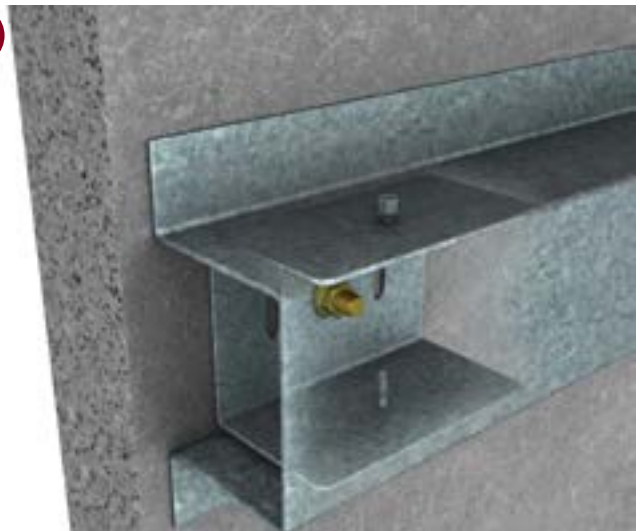

■ TOP HAT FIXED TO CONCRETE
ANCHOR SIZE TO CONCRETE/MASONRY 8-10mm AS SPECIFIED. TOP HAT TO CLEAT WITH #12 TEK SCREWS AS SHOWN

TOP HATS

Installation (continued)

INSTALLATION TO STEEL STUD FRAMING

Particularly with regards to External Stud Framing, Rondo Top Hats can be fixed either vertically with the adjustable cleats or direct fixed horizontally with packers if necessary.

If fixing vertically, the cleat method must be used as shown in Figure 3.

When fixing vertically, follow the top fixing and bottom fixing requirements shown in Figures 4 & 5.

At all times refer to the Serviceability Limit State Load Tables for the appropriate fixing dimensions on page [230](#) and ensure the Project Engineer has signed off on your proposal.

FIGURE 3

Screw fixing Cleat to Stud to be specified by Rondo as it depends on capacity required.

Top Hat to Cleat fixing with 2 x #12 Tek Screws as shown.

FIGURE 4

Top Hat to Slotted Deflection Head Track with 2 x #10 Tek Screws fixed at a maximum of 15mm from bottom of slot.

FIGURE 5

Top Hat to Base Track to be fixed with 2 x #10 Tek Screws at mid point of Track flange.



■ VERTICAL FIXING METHOD USING CLEAT



■ TOP FIXING



■ BOTTOM FIXING

Top Hat Fasteners

The preceding figures 1–3 illustrate the fixing of Top Hats to steelwork, masonry/concrete and to steel stud framing, detailing the appropriate Hex Head Tek screws to use.

Table 1 provides information on the capacities for #12 Hex Head Tek Screws when used in conjunction with the structural fixings methods suggested and set out as shown in Figure 6, either direct fixed through the Top Hat flanges as Figure 7 or when installing the Rondo Top Hat Cleats as in Figure 8.

In the case of fixing to masonry/concrete the relevant masonry anchor chosen should have, at the least, a capacity the same as that for the Tek screws shown in Table 1.

NOTE: When using Rondo Top Hats to install fibre cement sheeting with an express joint detail it is important to ensure the board manufacturers recommendations on edge distance for securing the board is considered when choosing the appropriate face width Top Hat profile. Similarly, building board manufacturers recommendations in respect to the installation of Control Joints should be followed closely to ensure proper function and performance of the system.

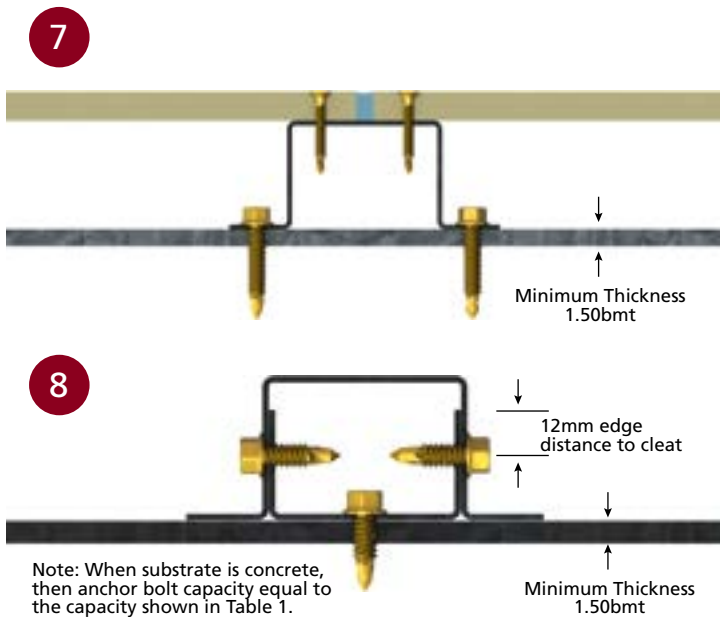
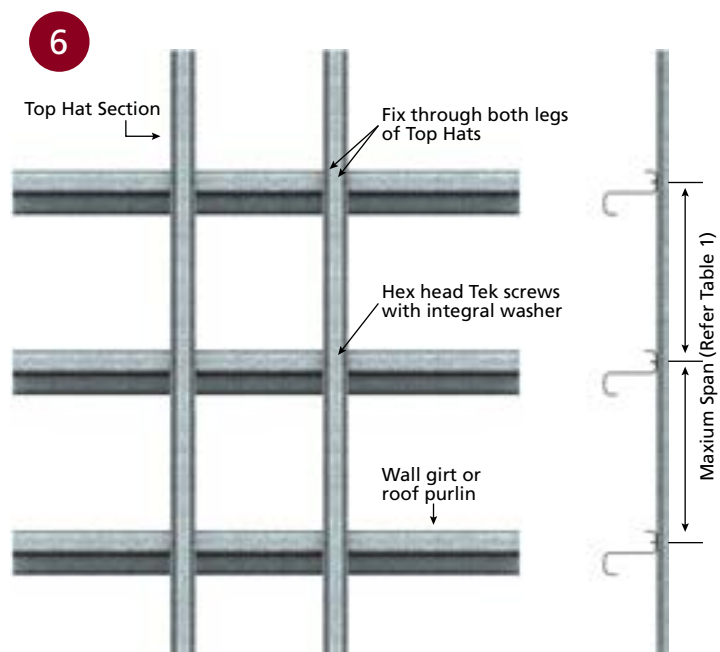

TABLE 1: #12 HEX HEAD FASTENERS

| TOP HAT SPAN | TOP HAT SPACING | NUMBER OF FASTENERS | ULTIMATE WIND LOAD (kPa) |
|--------------|-----------------|---------------------|--------------------------|
| 900 | 450 | 2 | 6.40 |
| | 600 | 2 | 4.80 |
| 1200 | 450 | 2 | 4.80 |
| | 600 | 2 | 3.60 |
| 1500 | 450 | 2 | 3.85 |
| | 600 | 2 | 2.90 |
| 1800 | 450 | 2 | 3.20 |
| | 600 | 2 | 2.40 |

NOTES:

1. Minimum thickness of supporting structure to be 1.50 bmt, G450 material - ie: purlin type support
2. Fastener head/washer diameter to be 12.5mm minimum
3. All screws to be manufactured in accordance with AS 3566. Screw coating to be selected based on installation requirements and manufacturers.

TOP HATS

Installation (continued)

INSTALLATION TO STEEL STUD FRAMING USING RONDO NOGGING TRACK

Some façade systems require the installation of Top Hats vertically and there will be occasions where studs do not coincide with the Top Hat spacing requirement. That being the case, it may be necessary to install Top Hats onto the steel Nogging Track.

There are strict limitations of fixing to Nogging Track and therefore, any such situation that requires this method needs to be referred to your Rondo Representative who will first seek written approval from Rondo's Technical Services Department.

If approved by Rondo's Technical Services Department, it will be necessary to ensure the junction between the stud and the Nogging track is strengthened by the use of Rondo 545 brackets (Figure 9) and installed as shown in Figures 10 and 11.

It is important that these details are followed as failure to follow this procedure may jeopardise onsite safety and system performance, and as such, invalidate the Rondo warranty.

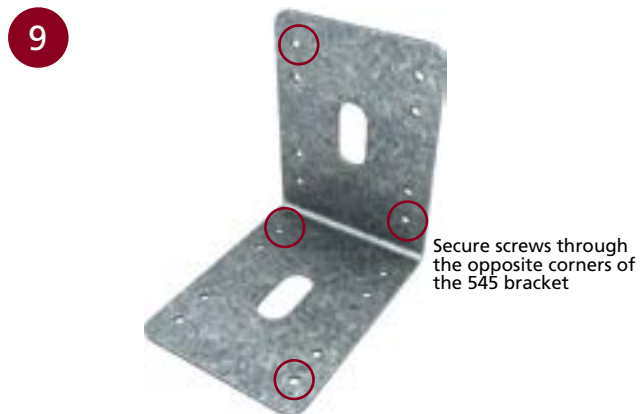

■ 545 BRACKET

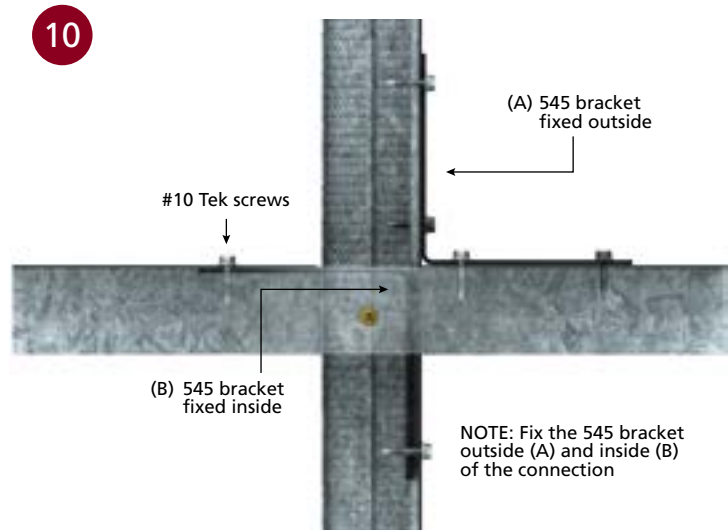

Section Dimensions

MATERIAL SPECIFICATIONS

The sections are cold roll formed from zinc coated steel strip, which is manufactured to AS1397.

Steel Grade: G2

Yield Strength: $F_y = 270$ MPa (typical)

Coating Grade: Z275 – 275g/m² zinc

Base Metal Thickness: As specified

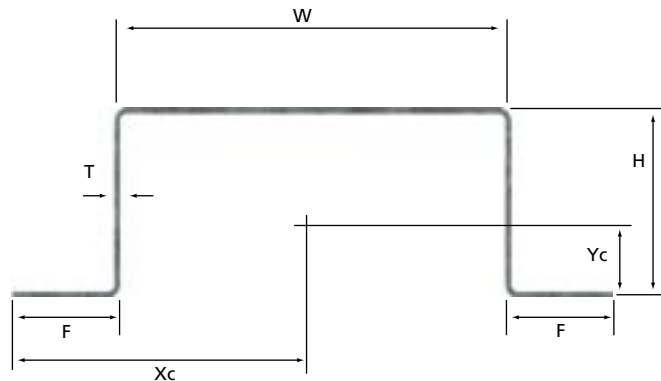

TABLE 2

| RONDO PART NO | AREA (mm ²) | T (BMT) (mm) | W (mm) | H (mm) | F (mm) | Xc (mm) | Yc (mm) | YIELD STRESS (MPa) | SELF-WEIGHT (kg/m) |
|---------------|-------------------------|--------------|--------|--------|--------|---------|---------|--------------------|--------------------|
| M515 | 79.45 | 0.75 | 50.0 | 15.0 | 15.0 | 40.1 | 6.27 | 270 | 0.61 |
| M525 | 97.45 | 0.75 | 50.0 | 25.0 | 20.0 | 42.1 | 11.17 | 270 | 0.75 |
| M535 | 111.7 | 0.75 | 50.0 | 35.0 | 20.0 | 41.6 | 15.74 | 270 | 0.89 |
| M545 | 127.1 | 0.75 | 50.0 | 45.0 | 18.4 | 42.6 | 20.61 | 270 | 1.05 |
| M550 | 134.2 | 0.75 | 50.0 | 50.0 | 20.0 | 41.6 | 22.89 | 270 | 1.08 |
| M560 | 150.0 | 0.75 | 50.0 | 60.0 | 18.4 | 42.6 | 27.90 | 270 | 1.24 |
| M715 | 97.45 | 0.75 | 75.0 | 15.0 | 15.0 | 52.1 | 5.07 | 270 | 0.78 |
| M725 | 115.4 | 0.75 | 75.0 | 25.0 | 20.0 | 54.1 | 9.33 | 270 | 0.95 |
| M735 | 131.2 | 0.75 | 75.0 | 35.0 | 20.0 | 54.6 | 13.65 | 270 | 1.06 |
| M750 | 153.7 | 0.75 | 75.0 | 50.0 | 20.0 | 54.6 | 20.28 | 270 | 1.26 |
| H515 | 117.2 | 1.15 | 50.0 | 15.0 | 15.0 | 38.67 | 6.12 | 270 | 0.91 |
| H525 | 147.1 | 1.15 | 50.0 | 25.0 | 20.0 | 41.67 | 11.16 | 270 | 1.19 |
| H535 | 169.4 | 1.15 | 50.0 | 35.0 | 20.0 | 41.37 | 15.78 | 270 | 1.37 |
| H545 | 192.0 | 1.15 | 50.0 | 45.0 | 18.2 | 42.0 | 20.54 | 270 | 1.56 |
| H550 | 204.6 | 1.15 | 50.0 | 50.0 | 20.0 | 41.67 | 23.03 | 270 | 1.66 |
| H560 | 226.2 | 1.15 | 50.0 | 60.0 | 18.2 | 42.0 | 27.80 | 270 | 1.84 |
| H715 | 147.1 | 1.15 | 75.0 | 15.0 | 15.0 | 51.67 | 5.10 | 270 | 1.16 |
| H725 | 175.9 | 1.15 | 75.0 | 25.0 | 20.0 | 54.17 | 9.43 | 270 | 1.43 |
| H735 | 198.9 | 1.15 | 75.0 | 35.0 | 20.0 | 54.17 | 13.65 | 270 | 1.61 |
| H750 | 235.7 | 1.15 | 75.0 | 50.0 | 20.0 | 55.17 | 20.55 | 270 | 1.89 |

TOP HATS

Serviceability Limit State Load Tables (kPa)

0.75bmt (M) Top Hats

TABLE 3: PART NO. M515: 15 x 15 x 50 x 15 x 15mm

| SPAN | M515 TOP HAT SPACING | | | | | | | |
|------|----------------------|------|-----------------|------|-------------|------|-----------------|------|
| | L / 250 | | | | L / 360 | | | |
| | SINGLE SPAN | | CONTINUOUS SPAN | | SINGLE SPAN | | CONTINUOUS SPAN | |
| | 450 | 600 | 450 | 600 | 450 | 600 | 450 | 600 |
| 900 | 0.58 | 0.43 | 1.10 | 0.82 | 0.39 | 0.29 | 0.76 | 0.57 |
| 1000 | 0.41 | 0.31 | 0.80 | 0.59 | 0.28 | NA | 0.55 | 0.41 |
| 1100 | 0.31 | NA | 0.60 | 0.44 | NA | NA | 0.41 | 0.30 |
| 1200 | NA | NA | 0.45 | 0.34 | NA | NA | 0.31 | NA |
| 1300 | NA | NA | 0.35 | 0.26 | NA | NA | NA | NA |
| 1400 | NA | NA | 0.28 | NA | NA | NA | NA | NA |
| 1500 | NA | NA | NA | NA | NA | NA | NA | NA |
| 1600 | NA | NA | NA | NA | NA | NA | NA | NA |
| 1700 | NA | NA | NA | NA | NA | NA | NA | NA |
| 1800 | NA | NA | NA | NA | NA | NA | NA | NA |

TABLE 4: PART NO. M525: 20 x 25 x 50 x 25 x 20mm

| SPAN | M525 TOP HAT SPACING | | | | | | | |
|------|----------------------|------|-----------------|------|-------------|------|-----------------|------|
| | L / 250 | | | | L / 360 | | | |
| | SINGLE SPAN | | CONTINUOUS SPAN | | SINGLE SPAN | | CONTINUOUS SPAN | |
| | 450 | 600 | 450 | 600 | 450 | 600 | 450 | 600 |
| 900 | 1.96 | 1.46 | 3.72 | 2.78 | 1.35 | 1.01 | 2.57 | 1.93 |
| 1000 | 1.42 | 1.06 | 2.70 | 2.02 | 0.98 | 0.73 | 1.87 | 1.40 |
| 1100 | 1.06 | 0.79 | 2.03 | 1.51 | 0.73 | 0.54 | 1.40 | 1.05 |
| 1200 | 0.82 | 0.61 | 1.56 | 1.16 | 0.56 | 0.41 | 1.07 | 0.80 |
| 1300 | 0.64 | 0.47 | 1.22 | 0.91 | 0.44 | 0.32 | 0.84 | 0.63 |
| 1400 | 0.51 | 0.37 | 0.97 | 0.72 | 0.35 | 0.25 | 0.67 | 0.50 |
| 1500 | 0.41 | 0.30 | 0.79 | 0.59 | 0.28 | NA | 0.54 | 0.40 |
| 1600 | 0.33 | NA | 0.64 | 0.48 | NA | NA | 0.44 | 0.33 |
| 1700 | 0.27 | NA | 0.53 | 0.40 | NA | NA | 0.36 | 0.27 |
| 1800 | NA | NA | 0.45 | 0.33 | NA | NA | 0.30 | NA |

NOTES:

1. NA means the maximum kPa value is less than 0.25 kPa and the top hat configuration is not appropriate
2. Serviceability limit state load capacity to be calculated in accordance with AS/NZS 1170.0 or AS/NZS 1170.2 as applicable
3. Connections to be independently checked
4. Ultimate limit state to be checked separately
5. Lining contribution not included
6. Cantilever not to exceed 0.2 times the backspan

TABLE 5: PART NO. M535: 20 x 35 x 50 x 35 x 20mm

| SPAN | M535 TOP HAT SPACING | | | | | | | |
|-------------|----------------------|------|-----------------|------|-------------|------|-----------------|------|
| | L / 250 | | | | L / 360 | | | |
| | SINGLE SPAN | | CONTINUOUS SPAN | | SINGLE SPAN | | CONTINUOUS SPAN | |
| | 450 | 600 | 450 | 600 | 450 | 600 | 450 | 600 |
| 900 | 4.17 | 3.12 | 7.88 | 5.90 | 2.89 | 2.16 | 5.47 | 4.09 |
| 1000 | 3.03 | 2.27 | 5.74 | 4.30 | 2.10 | 1.57 | 3.98 | 2.98 |
| 1100 | 2.27 | 1.70 | 4.31 | 3.22 | 1.57 | 1.17 | 2.98 | 2.23 |
| 1200 | 1.75 | 1.30 | 3.31 | 2.48 | 1.21 | 0.90 | 2.29 | 1.72 |
| 1300 | 1.37 | 1.02 | 2.60 | 1.95 | 0.94 | 0.70 | 1.80 | 1.35 |
| 1400 | 1.09 | 0.81 | 2.08 | 1.55 | 0.75 | 0.56 | 1.44 | 1.07 |
| 1500 | 0.88 | 0.66 | 1.69 | 1.26 | 0.61 | 0.45 | 1.16 | 0.87 |
| 1600 | 0.73 | 0.54 | 1.39 | 1.03 | 0.50 | 0.37 | 0.96 | 0.71 |
| 1700 | 0.60 | 0.45 | 1.15 | 0.86 | 0.41 | 0.30 | 0.79 | 0.59 |
| 1800 | 0.50 | 0.37 | 0.97 | 0.72 | 0.34 | 0.25 | 0.67 | 0.49 |

TABLE 6: PART NO. M545: 20 x 45 x 50 x 45 x 20mm

| SPAN | M545 TOP HAT SPACING | | | | | | | |
|-------------|----------------------|------|-----------------|------|-------------|------|-----------------|------|
| | L / 250 | | | | L / 360 | | | |
| | SINGLE SPAN | | CONTINUOUS SPAN | | SINGLE SPAN | | CONTINUOUS SPAN | |
| | 450 | 600 | 450 | 600 | 450 | 600 | 450 | 600 |
| 900 | 6.07 | 4.55 | 7.15 | 5.36 | 5.12 | 3.84 | 7.15 | 5.36 |
| 1000 | 4.61 | 3.45 | 5.79 | 4.34 | 3.72 | 2.79 | 5.79 | 4.34 |
| 1100 | 3.53 | 2.64 | 4.79 | 3.59 | 2.79 | 2.09 | 4.79 | 3.59 |
| 1200 | 2.71 | 2.03 | 4.03 | 3.02 | 2.14 | 1.61 | 4.03 | 3.02 |
| 1300 | 2.08 | 1.56 | 3.42 | 2.56 | 1.68 | 1.26 | 3.24 | 2.43 |
| 1400 | 1.60 | 1.20 | 2.91 | 2.18 | 1.34 | 1.00 | 2.59 | 1.94 |
| 1500 | 1.26 | 0.94 | 2.49 | 1.87 | 1.08 | 0.81 | 2.10 | 1.57 |
| 1600 | 1.00 | 0.75 | 2.16 | 1.62 | 0.89 | 0.67 | 1.73 | 1.29 |
| 1700 | 0.81 | 0.61 | 1.88 | 1.41 | 0.74 | 0.55 | 1.43 | 1.07 |
| 1800 | 0.66 | 0.50 | 1.63 | 1.22 | 0.62 | 0.46 | 1.20 | 0.90 |

NOTES:

1. NA means the maximum kPa value is less than 0.25 kPa and the Top Hat configuration is not appropriate
2. Serviceability limit state load capacity to be calculated in accordance with AS/NZS 1170.0 or AS/NZS 1170.2 as applicable
3. Connections to be independently checked
4. Ultimate limit state to be checked separately
5. Lining contribution not included
6. Cantilever not to exceed 0.2 times the backspan

TOP HATS

Serviceability Limit State Load Tables (kPa)

0.75bmt (M) Top Hats (continued)

TABLE 7: PART NO. M550: 20 x 50 x 50 x 50 x 20mm

| SPAN | M550 TOP HAT SPACING | | | | | | | |
|------|----------------------|------|-----------------|-------|-------------|------|-----------------|------|
| | L / 250 | | | | L / 360 | | | |
| | SINGLE SPAN | | CONTINUOUS SPAN | | SINGLE SPAN | | CONTINUOUS SPAN | |
| | 450 | 600 | 450 | 600 | 450 | 600 | 450 | 600 |
| 900 | 9.51 | 7.13 | 17.97 | 13.47 | 6.60 | 4.94 | 12.47 | 9.35 |
| 1000 | 6.93 | 5.19 | 13.09 | 9.81 | 4.81 | 3.60 | 9.09 | 6.81 |
| 1100 | 5.20 | 3.90 | 9.83 | 7.37 | 3.61 | 2.70 | 6.82 | 5.11 |
| 1200 | 4.00 | 3.00 | 7.57 | 5.67 | 2.77 | 2.07 | 5.25 | 3.93 |
| 1300 | 3.14 | 2.35 | 5.95 | 4.46 | 2.18 | 1.63 | 4.12 | 3.09 |
| 1400 | 2.51 | 1.88 | 4.76 | 3.56 | 1.74 | 1.30 | 3.30 | 2.47 |
| 1500 | 2.04 | 1.52 | 3.86 | 2.89 | 1.41 | 1.05 | 2.68 | 2.00 |
| 1600 | 1.68 | 1.25 | 3.18 | 2.38 | 1.16 | 0.86 | 2.20 | 1.65 |
| 1700 | 1.39 | 1.04 | 2.65 | 1.98 | 0.96 | 0.72 | 1.83 | 1.37 |
| 1800 | 1.17 | 0.87 | 2.23 | 1.67 | 0.81 | 0.60 | 1.54 | 1.15 |

TABLE 8: PART NO. M560: 20 x 60 x 50 x 60 x 20mm

| SPAN | M560 TOP HAT SPACING | | | | | | | |
|------|----------------------|------|-----------------|------|-------------|------|-----------------|------|
| | L / 250 | | | | L / 360 | | | |
| | SINGLE SPAN | | CONTINUOUS SPAN | | SINGLE SPAN | | CONTINUOUS SPAN | |
| | 450 | 600 | 450 | 600 | 450 | 600 | 450 | 600 |
| 900 | 9.60 | 7.20 | 10.98 | 8.24 | 9.60 | 7.20 | 10.98 | 8.24 |
| 1000 | 7.33 | 5.50 | 8.90 | 6.67 | 7.33 | 5.50 | 8.90 | 6.67 |
| 1100 | 5.66 | 4.24 | 7.36 | 5.52 | 5.63 | 4.22 | 7.36 | 5.52 |
| 1200 | 4.38 | 3.29 | 6.19 | 4.64 | 4.33 | 3.25 | 6.19 | 4.64 |
| 1300 | 3.39 | 2.54 | 5.27 | 3.95 | 3.39 | 2.54 | 5.27 | 3.95 |
| 1400 | 2.62 | 1.96 | 4.53 | 3.40 | 2.62 | 1.96 | 4.53 | 3.40 |
| 1500 | 2.04 | 1.53 | 3.90 | 2.92 | 2.04 | 1.53 | 3.90 | 2.92 |
| 1600 | 1.61 | 1.21 | 3.37 | 2.53 | 1.61 | 1.21 | 3.37 | 2.53 |
| 1700 | 1.30 | 0.97 | 2.94 | 2.21 | 1.30 | 0.97 | 2.91 | 2.18 |
| 1800 | 1.05 | 0.79 | 2.54 | 1.90 | 1.05 | 0.79 | 2.44 | 1.83 |

NOTES:

1. NA means the maximum kPa value is less than 0.25 kPa and the top hat configuration is not appropriate
2. Serviceability limit state load capacity to be calculated in accordance with AS/NZS 1170.0 or AS/NZS 1170.2 as applicable
3. Connections to be independently checked
4. Ultimate limit state to be checked separately
5. Lining contribution not included
6. Cantilever not to exceed 0.2 times the backspan

TABLE 9: PART NO. M715: 15 x 15 x 75 x 15 x 15mm

| SPAN | M715 TOP HAT SPACING | | | | | | | |
|------|----------------------|------|-----------------|------|-------------|------|-----------------|------|
| | L / 250 | | | | L / 360 | | | |
| | SINGLE SPAN | | CONTINUOUS SPAN | | SINGLE SPAN | | CONTINUOUS SPAN | |
| | 450 | 600 | 450 | 600 | 450 | 600 | 450 | 600 |
| 900 | 0.66 | 0.49 | 1.27 | 0.94 | 0.45 | 0.34 | 0.87 | 0.65 |
| 1000 | 0.48 | 0.35 | 0.92 | 0.68 | 0.33 | NA | 0.63 | 0.47 |
| 1100 | 0.35 | 0.26 | 0.68 | 0.51 | NA | NA | 0.47 | 0.35 |
| 1200 | 0.27 | NA | 0.52 | 0.39 | NA | NA | 0.36 | 0.26 |
| 1300 | NA | NA | 0.41 | 0.30 | NA | NA | 0.28 | NA |
| 1400 | NA | NA | 0.32 | NA | NA | NA | NA | NA |
| 1500 | NA | NA | 0.26 | NA | NA | NA | NA | NA |
| 1600 | NA | NA | NA | NA | NA | NA | NA | NA |
| 1700 | NA | NA | NA | NA | NA | NA | NA | NA |
| 1800 | NA | NA | NA | NA | NA | NA | NA | NA |

TABLE 10: PART NO. M725: 20 x 25 x 75 x 25 x 20mm

| SPAN | M725 TOP HAT SPACING | | | | | | | |
|------|----------------------|------|-----------------|------|-------------|------|-----------------|------|
| | L / 250 | | | | L / 360 | | | |
| | SINGLE SPAN | | CONTINUOUS SPAN | | SINGLE SPAN | | CONTINUOUS SPAN | |
| | 450 | 600 | 450 | 600 | 450 | 600 | 450 | 600 |
| 900 | 2.27 | 1.70 | 4.30 | 3.22 | 1.57 | 1.17 | 2.98 | 2.23 |
| 1000 | 1.65 | 1.23 | 3.13 | 2.34 | 1.14 | 0.85 | 2.17 | 1.62 |
| 1100 | 1.23 | 0.92 | 2.35 | 1.76 | 0.85 | 0.63 | 1.62 | 1.21 |
| 1200 | 0.95 | 0.70 | 1.80 | 1.35 | 0.65 | 0.48 | 1.25 | 0.93 |
| 1300 | 0.74 | 0.55 | 1.41 | 1.06 | 0.51 | 0.38 | 0.98 | 0.73 |
| 1400 | 0.59 | 0.44 | 1.13 | 0.84 | 0.40 | 0.30 | 0.78 | 0.58 |
| 1500 | 0.47 | 0.35 | 0.91 | 0.68 | 0.32 | NA | 0.63 | 0.47 |
| 1600 | 0.39 | 0.29 | 0.75 | 0.56 | 0.26 | NA | 0.51 | 0.38 |
| 1700 | 0.32 | NA | 0.62 | 0.46 | NA | NA | 0.43 | 0.31 |
| 1800 | 0.27 | NA | 0.52 | 0.39 | NA | NA | 0.36 | 0.26 |

NOTES:

1. NA means the maximum kPa value is less than 0.25 kPa and the Top Hat configuration is not appropriate
2. Serviceability limit state load capacity to be calculated in accordance with AS/NZS 1170.0 or AS/NZS 1170.2 as applicable
3. Connections to be independently checked
4. Ultimate limit state to be checked separately
5. Lining contribution not included
6. Cantilever not to exceed 0.2 times the backspan

TOP HATS

Serviceability Limit State Load Tables (kPa)

0.75bmt (M) Top Hats (continued)

TABLE 11: PART NO. M735: 20 x 35 x 75 x 35 x 20mm

| SPAN | M735 TOP HAT SPACING | | | | | | | |
|------|----------------------|------|-----------------|------|-------------|------|-----------------|------|
| | L / 250 | | | | L / 360 | | | |
| | SINGLE SPAN | | CONTINUOUS SPAN | | SINGLE SPAN | | CONTINUOUS SPAN | |
| | 450 | 600 | 450 | 600 | 450 | 600 | 450 | 600 |
| 900 | 4.94 | 3.70 | 9.34 | 7.00 | 3.42 | 2.56 | 6.48 | 4.85 |
| 1000 | 3.59 | 2.69 | 6.80 | 5.09 | 2.49 | 1.86 | 4.72 | 3.53 |
| 1100 | 2.70 | 2.02 | 5.10 | 3.82 | 1.87 | 1.39 | 3.54 | 2.65 |
| 1200 | 2.07 | 1.55 | 3.93 | 2.94 | 1.43 | 1.07 | 2.72 | 2.04 |
| 1300 | 1.62 | 1.21 | 3.08 | 2.31 | 1.12 | 0.84 | 2.14 | 1.60 |
| 1400 | 1.30 | 0.97 | 2.47 | 1.84 | 0.89 | 0.67 | 1.71 | 1.27 |
| 1500 | 1.05 | 0.78 | 2.00 | 1.50 | 0.72 | 0.54 | 1.38 | 1.03 |
| 1600 | 0.86 | 0.64 | 1.65 | 1.23 | 0.59 | 0.44 | 1.14 | 0.85 |
| 1700 | 0.72 | 0.53 | 1.37 | 1.02 | 0.49 | 0.36 | 0.94 | 0.70 |
| 1800 | 0.60 | 0.44 | 1.15 | 0.86 | 0.41 | 0.30 | 0.79 | 0.59 |

TABLE 12: PART NO. M750: 20 x 50 x 75 x 50 x 20mm

| SPAN | M750 TOP HAT SPACING | | | | | | | |
|------|----------------------|------|-----------------|-------|-------------|------|-----------------|-------|
| | L / 250 | | | | L / 360 | | | |
| | SINGLE SPAN | | CONTINUOUS SPAN | | SINGLE SPAN | | CONTINUOUS SPAN | |
| | 450 | 600 | 450 | 600 | 450 | 600 | 450 | 600 |
| 900 | 11.19 | 8.39 | 21.14 | 15.85 | 7.77 | 5.82 | 14.68 | 11.00 |
| 1000 | 8.16 | 6.11 | 15.41 | 11.55 | 5.66 | 4.24 | 10.69 | 8.02 |
| 1100 | 6.12 | 4.59 | 11.57 | 8.67 | 4.25 | 3.18 | 8.03 | 6.02 |
| 1200 | 4.71 | 3.53 | 8.91 | 6.68 | 3.27 | 2.44 | 6.18 | 4.63 |
| 1300 | 3.70 | 2.77 | 7.00 | 5.25 | 2.56 | 1.92 | 4.86 | 3.64 |
| 1400 | 2.96 | 2.21 | 5.60 | 4.20 | 2.05 | 1.53 | 3.88 | 2.91 |
| 1500 | 2.40 | 1.80 | 4.55 | 3.41 | 1.66 | 1.24 | 3.15 | 2.36 |
| 1600 | 1.98 | 1.48 | 3.75 | 2.80 | 1.37 | 1.02 | 2.60 | 1.94 |
| 1700 | 1.64 | 1.23 | 3.12 | 2.34 | 1.14 | 0.85 | 2.16 | 1.62 |
| 1800 | 1.38 | 1.03 | 2.63 | 1.96 | 0.95 | 0.71 | 1.82 | 1.36 |

NOTES:

1. NA means the maximum kPa value is less than 0.25 kPa and the top hat configuration is not appropriate
2. Serviceability limit state load capacity to be calculated in accordance with AS/NZS 1170.0 or AS/NZS 1170.2 as applicable
3. Connections to be independently checked
4. Ultimate limit state to be checked separately
5. Lining contribution not included
6. Cantilever not to exceed 0.2 times the backspan

Serviceability Limit State Load Tables (kPa)
1.15bmt (H) Top Hats

TABLE 13: PART NO. H515: 15 x 15 x 50 x 15 x 15mm

| SPAN | H515 TOP HAT SPACING | | | | | | | |
|-------------|----------------------|------|-----------------|------|-------------|------|-----------------|------|
| | L / 250 | | | | L / 360 | | | |
| | SINGLE SPAN | | CONTINUOUS SPAN | | SINGLE SPAN | | CONTINUOUS SPAN | |
| | 450 | 600 | 450 | 600 | 450 | 600 | 450 | 600 |
| 900 | 0.80 | 0.59 | 1.52 | 1.14 | 0.55 | 0.41 | 1.05 | 0.78 |
| 1000 | 0.58 | 0.43 | 1.10 | 0.82 | 0.39 | 0.29 | 0.76 | 0.57 |
| 1100 | 0.43 | 0.32 | 0.82 | 0.61 | 0.29 | NA | 0.57 | 0.42 |
| 1200 | 0.32 | NA | 0.63 | 0.47 | NA | NA | 0.43 | 0.32 |
| 1300 | 0.25 | NA | 0.49 | 0.36 | NA | NA | 0.34 | NA |
| 1400 | NA | NA | 0.39 | 0.29 | NA | NA | 0.26 | NA |
| 1500 | NA | NA | 0.31 | NA | NA | NA | NA | NA |
| 1600 | NA | NA | 0.25 | NA | NA | NA | NA | NA |
| 1700 | NA | NA | NA | NA | NA | NA | NA | NA |
| 1800 | NA | NA | NA | NA | NA | NA | NA | NA |

TABLE 14: PART NO. H525: 20 x 25 x 50 x 25 x 20mm

| SPAN | H525 TOP HAT SPACING | | | | | | | |
|-------------|----------------------|------|-----------------|------|-------------|------|-----------------|------|
| | L / 250 | | | | L / 360 | | | |
| | SINGLE SPAN | | CONTINUOUS SPAN | | SINGLE SPAN | | CONTINUOUS SPAN | |
| | 450 | 600 | 450 | 600 | 450 | 600 | 450 | 600 |
| 900 | 2.87 | 2.15 | 5.43 | 4.07 | 1.99 | 1.49 | 3.77 | 2.82 |
| 1000 | 2.09 | 1.56 | 3.96 | 2.96 | 1.44 | 1.08 | 2.74 | 2.05 |
| 1100 | 1.56 | 1.17 | 2.97 | 2.22 | 1.08 | 0.80 | 2.05 | 1.54 |
| 1200 | 1.20 | 0.89 | 2.28 | 1.71 | 0.83 | 0.61 | 1.58 | 1.18 |
| 1300 | 0.94 | 0.70 | 1.79 | 1.34 | 0.65 | 0.48 | 1.24 | 0.92 |
| 1400 | 0.75 | 0.56 | 1.43 | 1.07 | 0.51 | 0.38 | 0.99 | 0.73 |
| 1500 | 0.60 | 0.45 | 1.16 | 0.86 | 0.41 | 0.31 | 0.80 | 0.59 |
| 1600 | 0.49 | 0.37 | 0.95 | 0.71 | 0.34 | NA | 0.65 | 0.49 |
| 1700 | 0.41 | 0.30 | 0.79 | 0.59 | 0.28 | NA | 0.54 | 0.40 |
| 1800 | 0.34 | 0.25 | 0.66 | 0.49 | NA | NA | 0.45 | 0.34 |

NOTES:

1. NA means the maximum kPa value is less than 0.25 kPa and the Top Hat configuration is not appropriate
2. Serviceability limit state load capacity to be calculated in accordance with AS/NZS 1170.0 or AS/NZS 1170.2 as applicable
3. Connections to be independently checked
4. Ultimate limit state to be checked separately
5. Lining contribution not included
6. Cantilever not to exceed 0.2 times the backspan

TOP HATS

Serviceability Limit State Load Tables (kPa)

1.15bmt (H) Top Hats (continued)

TABLE 15: PART NO. H535: 20 x 35 x 50 x 35 x 20mm

| SPAN | H535 TOP HAT SPACING | | | | | | | |
|------|----------------------|------|-----------------|------|-------------|------|-----------------|------|
| | L / 250 | | | | L / 360 | | | |
| | SINGLE SPAN | | CONTINUOUS SPAN | | SINGLE SPAN | | CONTINUOUS SPAN | |
| | 450 | 600 | 450 | 600 | 450 | 600 | 450 | 600 |
| 900 | 6.18 | 4.63 | 11.69 | 8.76 | 4.29 | 3.21 | 8.11 | 6.08 |
| 1000 | 4.50 | 3.37 | 8.51 | 6.38 | 3.12 | 2.34 | 5.91 | 4.42 |
| 1100 | 3.38 | 2.53 | 6.39 | 4.79 | 2.34 | 1.75 | 4.43 | 3.32 |
| 1200 | 2.60 | 1.94 | 4.92 | 3.68 | 1.80 | 1.34 | 3.41 | 2.55 |
| 1300 | 2.04 | 1.52 | 3.86 | 2.89 | 1.41 | 1.05 | 2.68 | 2.00 |
| 1400 | 1.63 | 1.22 | 3.09 | 2.31 | 1.12 | 0.84 | 2.14 | 1.60 |
| 1500 | 1.32 | 0.98 | 2.51 | 1.88 | 0.91 | 0.68 | 1.74 | 1.30 |
| 1600 | 1.08 | 0.81 | 2.06 | 1.54 | 0.75 | 0.56 | 1.43 | 1.07 |
| 1700 | 0.90 | 0.67 | 1.72 | 1.28 | 0.62 | 0.46 | 1.19 | 0.88 |
| 1800 | 0.76 | 0.56 | 1.44 | 1.08 | 0.52 | 0.38 | 1.00 | 0.74 |

TABLE 16: PART NO. H545: 20 x 45 x 50 x 45 x 20mm

| SPAN | H545 TOP HAT SPACING | | | | | | | |
|------|----------------------|------|-----------------|------|-------------|------|-----------------|------|
| | L / 250 | | | | L / 360 | | | |
| | SINGLE SPAN | | CONTINUOUS SPAN | | SINGLE SPAN | | CONTINUOUS SPAN | |
| | 450 | 600 | 450 | 600 | 450 | 600 | 450 | 600 |
| 900 | 10.96 | 8.22 | 12.61 | 9.45 | 7.89 | 5.92 | 12.61 | 9.45 |
| 1000 | 8.28 | 6.21 | 10.22 | 7.66 | 5.74 | 4.30 | 10.22 | 7.66 |
| 1100 | 6.21 | 4.66 | 8.45 | 6.33 | 4.30 | 3.23 | 8.28 | 6.21 |
| 1200 | 4.78 | 3.58 | 7.10 | 5.33 | 3.31 | 2.48 | 6.37 | 4.77 |
| 1300 | 3.75 | 2.81 | 6.06 | 4.54 | 2.59 | 1.94 | 5.00 | 3.75 |
| 1400 | 2.99 | 2.24 | 5.16 | 3.87 | 2.07 | 1.55 | 3.99 | 2.99 |
| 1500 | 2.43 | 1.82 | 4.44 | 3.33 | 1.67 | 1.25 | 3.24 | 2.43 |
| 1600 | 1.99 | 1.49 | 3.82 | 2.86 | 1.37 | 1.03 | 2.66 | 2.00 |
| 1700 | 1.66 | 1.24 | 3.21 | 2.40 | 1.14 | 0.85 | 2.21 | 1.66 |
| 1800 | 1.38 | 1.03 | 2.69 | 2.02 | 0.95 | 0.71 | 1.86 | 1.39 |

NOTES:

1. NA means the maximum kPa value is less than 0.25 kPa and the top hat configuration is not appropriate
2. Serviceability limit state load capacity to be calculated in accordance with AS/NZS 1170.0 or AS/NZS 1170.2 as applicable
3. Connections to be independently checked
4. Ultimate limit state to be checked separately
5. Lining contribution not included
6. Cantilever not to exceed 0.2 times the backspan

TABLE 17: PART NO. H550: 20 x 50 x 50 x 50 x 20mm

| SPAN | H550 TOP HAT SPACING | | | | | | | |
|-------------|----------------------|-------|-----------------|-------|-------------|------|-----------------|-------|
| | L / 250 | | | | L / 360 | | | |
| | SINGLE SPAN | | CONTINUOUS SPAN | | SINGLE SPAN | | CONTINUOUS SPAN | |
| | 450 | 600 | 450 | 600 | 450 | 600 | 450 | 600 |
| 900 | 14.31 | 10.73 | 27.03 | 20.27 | 9.93 | 7.45 | 18.76 | 14.07 |
| 1000 | 10.43 | 7.82 | 19.70 | 14.77 | 7.24 | 5.42 | 13.67 | 10.25 |
| 1100 | 7.83 | 5.87 | 14.79 | 11.09 | 5.43 | 4.07 | 10.27 | 7.70 |
| 1200 | 6.03 | 4.52 | 11.39 | 8.54 | 4.18 | 3.13 | 7.90 | 5.92 |
| 1300 | 4.74 | 3.55 | 8.95 | 6.71 | 3.28 | 2.46 | 6.21 | 4.65 |
| 1400 | 3.79 | 2.84 | 7.17 | 5.37 | 2.62 | 1.96 | 4.97 | 3.72 |
| 1500 | 3.08 | 2.30 | 5.82 | 4.36 | 2.13 | 1.59 | 4.04 | 3.02 |
| 1600 | 2.53 | 1.89 | 4.79 | 3.59 | 1.75 | 1.31 | 3.32 | 2.49 |
| 1700 | 2.11 | 1.58 | 3.99 | 2.99 | 1.46 | 1.09 | 2.77 | 2.07 |
| 1800 | 1.77 | 1.32 | 3.36 | 2.52 | 1.22 | 0.91 | 2.33 | 1.74 |

TABLE 18: PART NO. H560: 20 x 60 x 50 x 60 x 20mm

| SPAN | H560 TOP HAT SPACING | | | | | | | |
|-------------|----------------------|-------|-----------------|-------|-------------|-------|-----------------|-------|
| | L / 250 | | | | L / 360 | | | |
| | SINGLE SPAN | | CONTINUOUS SPAN | | SINGLE SPAN | | CONTINUOUS SPAN | |
| | 450 | 600 | 450 | 600 | 450 | 600 | 450 | 600 |
| 900 | 16.82 | 12.61 | 19.00 | 14.25 | 15.68 | 11.76 | 19.00 | 14.25 |
| 1000 | 12.93 | 9.70 | 15.40 | 11.55 | 11.42 | 8.56 | 15.40 | 11.55 |
| 1100 | 10.07 | 7.55 | 12.73 | 9.55 | 8.57 | 6.43 | 12.73 | 9.55 |
| 1200 | 7.91 | 5.93 | 10.70 | 8.03 | 6.59 | 4.94 | 10.70 | 8.03 |
| 1300 | 6.23 | 4.67 | 9.12 | 6.84 | 5.17 | 3.88 | 9.12 | 6.84 |
| 1400 | 4.92 | 3.69 | 7.87 | 5.90 | 4.13 | 3.10 | 7.87 | 5.90 |
| 1500 | 3.88 | 2.91 | 6.72 | 5.04 | 3.35 | 2.51 | 6.46 | 4.85 |
| 1600 | 3.06 | 2.30 | 5.75 | 4.31 | 2.75 | 2.06 | 5.31 | 3.98 |
| 1700 | 2.46 | 1.84 | 4.94 | 3.71 | 2.29 | 1.72 | 4.42 | 3.32 |
| 1800 | 2.00 | 1.50 | 4.27 | 3.20 | 1.92 | 1.44 | 3.72 | 2.79 |

NOTES:

1. NA means the maximum kPa value is less than 0.25 kPa and the Top Hat configuration is not appropriate
2. Serviceability limit state load capacity to be calculated in accordance with AS/NZS 1170.0 or AS/NZS 1170.2 as applicable
3. Connections to be independently checked
4. Ultimate limit state to be checked separately
5. Lining contribution not included
6. Cantilever not to exceed 0.2 times the backspan

TOP HATS

Serviceability Limit State Load Tables (kPa)

1.15bmt (H) Top Hats (continued)

TABLE 19: PART NO. H715: 15 x 15 x 75 x 15 x 15mm

| SPAN | H715 TOP HAT SPACING | | | | | | | |
|------|----------------------|------|-----------------|------|-------------|------|-----------------|------|
| | L / 250 | | | | L / 360 | | | |
| | SINGLE SPAN | | CONTINUOUS SPAN | | SINGLE SPAN | | CONTINUOUS SPAN | |
| | 450 | 600 | 450 | 600 | 450 | 600 | 450 | 600 |
| 900 | 0.95 | 0.71 | 1.81 | 1.35 | 0.65 | 0.48 | 1.25 | 0.93 |
| 1000 | 0.69 | 0.51 | 1.31 | 0.98 | 0.47 | 0.35 | 0.91 | 0.67 |
| 1100 | 0.51 | 0.38 | 0.98 | 0.73 | 0.35 | 0.26 | 0.68 | 0.50 |
| 1200 | 0.39 | 0.29 | 0.75 | 0.56 | 0.26 | NA | 0.52 | 0.38 |
| 1300 | 0.30 | NA | 0.59 | 0.43 | NA | NA | 0.40 | 0.30 |
| 1400 | NA | NA | 0.47 | 0.34 | NA | NA | 0.32 | NA |
| 1500 | NA | NA | 0.37 | 0.28 | NA | NA | 0.25 | NA |
| 1600 | NA | NA | 0.31 | NA | NA | NA | NA | NA |
| 1700 | NA | NA | 0.25 | NA | NA | NA | NA | NA |
| 1800 | NA | NA | NA | NA | NA | NA | NA | NA |

TABLE 20: PART NO. H725: 20 x 25 x 75 x 25 x 20mm

| SPAN | H725 TOP HAT SPACING | | | | | | | |
|------|----------------------|------|-----------------|------|-------------|------|-----------------|------|
| | L / 250 | | | | L / 360 | | | |
| | SINGLE SPAN | | CONTINUOUS SPAN | | SINGLE SPAN | | CONTINUOUS SPAN | |
| | 450 | 600 | 450 | 600 | 450 | 600 | 450 | 600 |
| 900 | 3.37 | 2.53 | 6.38 | 4.78 | 2.34 | 1.75 | 4.43 | 3.32 |
| 1000 | 2.45 | 1.84 | 4.65 | 3.48 | 1.70 | 1.27 | 3.22 | 2.41 |
| 1100 | 1.84 | 1.37 | 3.49 | 2.61 | 1.27 | 0.95 | 2.42 | 1.81 |
| 1200 | 1.41 | 1.05 | 2.68 | 2.01 | 0.97 | 0.73 | 1.86 | 1.39 |
| 1300 | 1.11 | 0.82 | 2.10 | 1.57 | 0.76 | 0.57 | 1.46 | 1.09 |
| 1400 | 0.88 | 0.66 | 1.68 | 1.26 | 0.61 | 0.45 | 1.16 | 0.87 |
| 1500 | 0.71 | 0.53 | 1.36 | 1.02 | 0.49 | 0.36 | 0.94 | 0.70 |
| 1600 | 0.58 | 0.43 | 1.12 | 0.83 | 0.40 | 0.29 | 0.77 | 0.57 |
| 1700 | 0.48 | 0.36 | 0.93 | 0.69 | 0.33 | NA | 0.64 | 0.47 |
| 1800 | 0.40 | 0.30 | 0.78 | 0.58 | 0.27 | NA | 0.54 | 0.40 |

NOTES:

1. NA means the maximum kPa value is less than 0.25 kPa and the top hat configuration is not appropriate
2. Serviceability limit state load capacity to be calculated in accordance with AS/NZS 1170.0 or AS/NZS 1170.2 as applicable
3. Connections to be independently checked
4. Ultimate limit state to be checked separately
5. Lining contribution not included
6. Cantilever not to exceed 0.2 times the backspan

TABLE 21: PART NO. H735: 20 x 35 x 75 x 35 x 20mm

| SPAN | H735 TOP HAT SPACING | | | | | | | |
|-------------|----------------------|------|-----------------|-------|-------------|------|-----------------|------|
| | L / 250 | | | | L / 360 | | | |
| | SINGLE SPAN | | CONTINUOUS SPAN | | SINGLE SPAN | | CONTINUOUS SPAN | |
| | 450 | 600 | 450 | 600 | 450 | 600 | 450 | 600 |
| 900 | 7.30 | 5.47 | 13.80 | 10.35 | 5.07 | 3.80 | 9.58 | 7.18 |
| 1000 | 5.32 | 3.98 | 10.06 | 7.54 | 3.69 | 2.76 | 6.98 | 5.23 |
| 1100 | 3.99 | 2.99 | 7.55 | 5.66 | 2.77 | 2.07 | 5.24 | 3.92 |
| 1200 | 3.07 | 2.30 | 5.81 | 4.35 | 2.13 | 1.59 | 4.03 | 3.02 |
| 1300 | 2.41 | 1.80 | 4.57 | 3.42 | 1.67 | 1.25 | 3.17 | 2.37 |
| 1400 | 1.93 | 1.44 | 3.65 | 2.73 | 1.33 | 0.99 | 2.53 | 1.89 |
| 1500 | 1.56 | 1.17 | 2.97 | 2.22 | 1.08 | 0.80 | 2.05 | 1.54 |
| 1600 | 1.28 | 0.96 | 2.44 | 1.83 | 0.89 | 0.66 | 1.69 | 1.26 |
| 1700 | 1.07 | 0.80 | 2.03 | 1.52 | 0.73 | 0.55 | 1.40 | 1.05 |
| 1800 | 0.90 | 0.67 | 1.71 | 1.28 | 0.62 | 0.46 | 1.18 | 0.88 |

TABLE 22: PART NO. H750: 20 x 50 x 75 x 50 x 20mm

| SPAN | H750 TOP HAT SPACING | | | | | | | |
|-------------|----------------------|-------|-----------------|-------|-------------|------|-----------------|-------|
| | L / 250 | | | | L / 360 | | | |
| | SINGLE SPAN | | CONTINUOUS SPAN | | SINGLE SPAN | | CONTINUOUS SPAN | |
| | 450 | 600 | 450 | 600 | 450 | 600 | 450 | 600 |
| 900 | 17.06 | 12.79 | 32.21 | 24.15 | 11.84 | 8.87 | 22.36 | 16.76 |
| 1000 | 12.43 | 9.32 | 23.47 | 17.60 | 8.63 | 6.46 | 16.29 | 12.22 |
| 1100 | 9.33 | 6.99 | 17.63 | 13.22 | 6.48 | 4.85 | 12.24 | 9.17 |
| 1200 | 7.18 | 5.38 | 13.58 | 10.18 | 4.98 | 3.73 | 9.42 | 7.06 |
| 1300 | 5.65 | 4.23 | 10.67 | 8.00 | 3.92 | 2.93 | 7.41 | 5.55 |
| 1400 | 4.52 | 3.38 | 8.54 | 6.40 | 3.13 | 2.34 | 5.93 | 4.44 |
| 1500 | 3.67 | 2.75 | 6.94 | 5.20 | 2.54 | 1.90 | 4.81 | 3.61 |
| 1600 | 3.02 | 2.26 | 5.72 | 4.28 | 2.09 | 1.56 | 3.96 | 2.97 |
| 1700 | 2.51 | 1.88 | 4.76 | 3.57 | 1.74 | 1.30 | 3.30 | 2.47 |
| 1800 | 2.11 | 1.58 | 4.01 | 3.00 | 1.46 | 1.09 | 2.78 | 2.08 |

NOTES:

1. NA means the maximum kPa value is less than 0.25 kPa and the Top Hat configuration is not appropriate
2. Serviceability limit state load capacity to be calculated in accordance with AS/NZS 1170.0 or AS/NZS 1170.2 as applicable
3. Connections to be independently checked
4. Ultimate limit state to be checked separately
5. Lining contribution not included
6. Cantilever not to exceed 0.2 times the backspan

TOP HATS

Ultimate Limit State Load Tables (kPa)

0.75bmt (M) Top Hats

TABLE 23: PART NO. M515: 15 x 15 x 50 x 15 x 15mm

| SPAN | M515 TOP HAT SPACING | | | |
|------|----------------------|------|-----------------|------|
| | SINGLE SPAN | | CONTINUOUS SPAN | |
| | 450 | 600 | 450 | 600 |
| 900 | 1.07 | 0.80 | 1.45 | 1.08 |
| 1000 | 0.80 | 0.60 | 1.15 | 0.86 |
| 1100 | 0.61 | 0.45 | 0.93 | 0.69 |
| 1200 | 0.47 | 0.35 | 0.76 | 0.57 |
| 1300 | 0.38 | 0.28 | 0.63 | 0.47 |
| 1400 | 0.30 | 0.22 | 0.53 | 0.39 |
| 1500 | 0.25 | 0.18 | 0.45 | 0.33 |
| 1600 | 0.21 | 0.15 | 0.39 | 0.29 |
| 1700 | 0.18 | 0.13 | 0.34 | 0.25 |
| 1800 | 0.15 | 0.11 | 0.30 | 0.22 |

TABLE 24: PART NO. M525: 20 x 25 x 50 x 25 x 20mm

| SPAN | M525 TOP HAT SPACING | | | |
|------|----------------------|------|-----------------|------|
| | SINGLE SPAN | | CONTINUOUS SPAN | |
| | 450 | 600 | 450 | 600 |
| 900 | 2.31 | 1.73 | 3.12 | 2.34 |
| 1000 | 1.70 | 1.27 | 2.53 | 1.89 |
| 1100 | 1.25 | 0.93 | 2.09 | 1.56 |
| 1200 | 0.95 | 0.71 | 1.73 | 1.29 |
| 1300 | 0.74 | 0.55 | 1.42 | 1.06 |
| 1400 | 0.59 | 0.44 | 1.18 | 0.88 |
| 1500 | 0.47 | 0.35 | 0.98 | 0.73 |
| 1600 | 0.38 | 0.28 | 0.83 | 0.62 |
| 1700 | 0.31 | 0.23 | 0.70 | 0.52 |
| 1800 | 0.26 | 0.19 | 0.60 | 0.45 |

NOTES:

1. NA means the maximum kPa value is less than 0.25 kPa and the top hat configuration is not appropriate
2. Ultimate Limit state load capacity to be calculated in accordance with AS/NZS 1170.0 or AS/NZS 1170.2 as applicable
3. Connections to be independently checked
4. Serviceability limit state to be checked separately
5. Lining contribution not included
6. Cantilever not to exceed 0.2 times the backspan

TABLE 25: PART NO. M535: 20 x 35 x 50 x 35 x 20mm

| SPAN | M535 TOP HAT SPACING | | | |
|-------------|----------------------|------|-----------------|------|
| | SINGLE SPAN | | CONTINUOUS SPAN | |
| | 450 | 600 | 450 | 600 |
| 900 | 3.85 | 2.88 | 4.94 | 3.70 |
| 1000 | 2.85 | 2.13 | 4.00 | 3.00 |
| 1100 | 2.12 | 1.59 | 3.22 | 2.41 |
| 1200 | 1.57 | 1.17 | 2.60 | 1.95 |
| 1300 | 1.20 | 0.90 | 2.12 | 1.59 |
| 1400 | 0.92 | 0.69 | 1.75 | 1.31 |
| 1500 | 0.72 | 0.54 | 1.45 | 1.08 |
| 1600 | 0.57 | 0.42 | 1.21 | 0.90 |
| 1700 | 0.47 | 0.35 | 1.01 | 0.75 |
| 1800 | 0.38 | 0.28 | 0.85 | 0.63 |

TABLE 26: PART NO. M545: 20 x 45 x 50 x 45 x 20mm

| SPAN | M545 TOP HAT SPACING | | | |
|-------------|----------------------|------|-----------------|------|
| | SINGLE SPAN | | CONTINUOUS SPAN | |
| | 450 | 600 | 450 | 600 |
| 900 | 6.07 | 4.55 | 7.15 | 5.36 |
| 1000 | 4.61 | 3.45 | 5.79 | 4.34 |
| 1100 | 3.53 | 2.64 | 4.79 | 3.59 |
| 1200 | 2.71 | 2.03 | 4.03 | 3.02 |
| 1300 | 2.08 | 1.56 | 3.42 | 2.56 |
| 1400 | 1.60 | 1.20 | 2.91 | 2.18 |
| 1500 | 1.26 | 0.94 | 2.49 | 1.87 |
| 1600 | 1.00 | 0.75 | 2.16 | 1.62 |
| 1700 | 0.81 | 0.61 | 1.88 | 1.41 |
| 1800 | 0.66 | 0.50 | 1.63 | 1.22 |

NOTES:

1. NA means the maximum kPa value is less than 0.25 kPa and the Top Hat configuration is not appropriate
2. Ultimate Limit state load capacity to be calculated in accordance with AS/NZS 1170.0 or AS/NZS 1170.2 as applicable
3. Connections to be independently checked
4. Serviceability limit state to be checked separately
5. Lining contribution not included
6. Cantilever not to exceed 0.2 times the backspan

TOP HATS

Ultimate Limit State Load Tables:

0.75bmt (M) Top Hats (continued)

TABLE 27: PART NO. M550: 20 x 50 x 50 x 50 x 20mm

| SPAN | M550 TOP HAT SPACING | | | |
|------|----------------------|------|-----------------|------|
| | SINGLE SPAN | | CONTINUOUS SPAN | |
| | 450 | 600 | 450 | 600 |
| 900 | 6.65 | 4.98 | 8.30 | 6.22 |
| 1000 | 4.94 | 3.70 | 6.72 | 5.04 |
| 1100 | 3.68 | 2.76 | 5.37 | 4.02 |
| 1200 | 2.72 | 2.04 | 4.32 | 3.24 |
| 1300 | 2.04 | 1.53 | 3.52 | 2.64 |
| 1400 | 1.57 | 1.17 | 2.88 | 2.16 |
| 1500 | 1.21 | 0.90 | 2.37 | 1.77 |
| 1600 | 0.95 | 0.71 | 1.96 | 1.47 |
| 1700 | 0.76 | 0.57 | 1.62 | 1.21 |
| 1800 | 0.62 | 0.46 | 1.33 | 0.99 |

TABLE 28: PART NO. M560: 20 x 60 x 50 x 60 x 20mm

| SPAN | M560 TOP HAT SPACING | | | |
|------|----------------------|------|-----------------|------|
| | SINGLE SPAN | | CONTINUOUS SPAN | |
| | 450 | 600 | 450 | 600 |
| 900 | 9.60 | 7.20 | 10.98 | 8.24 |
| 1000 | 7.33 | 5.50 | 8.90 | 6.67 |
| 1100 | 5.66 | 4.24 | 7.36 | 5.52 |
| 1200 | 4.38 | 3.29 | 6.19 | 4.64 |
| 1300 | 3.39 | 2.54 | 5.27 | 3.95 |
| 1400 | 2.62 | 1.96 | 4.53 | 3.40 |
| 1500 | 2.04 | 1.53 | 3.90 | 2.92 |
| 1600 | 1.61 | 1.21 | 3.37 | 2.53 |
| 1700 | 1.30 | 0.97 | 2.94 | 2.21 |
| 1800 | 1.05 | 0.79 | 2.54 | 1.90 |

NOTES:

1. NA means the maximum kPa value is less than 0.25 kPa and the top hat configuration is not appropriate
2. Ultimate Limit state load capacity to be calculated in accordance with ASINZS 1170.0 or ASINZS 1170.2 as applicable
3. Connections to be independently checked
4. Serviceability limit state to be checked separately
5. Lining contribution not included
6. Cantilever not to exceed 0.2 times the backspan

TABLE 29: PART NO. M715: 15 x 15 x 75 x 15 x 15mm

| SPAN | M715 TOP HAT SPACING | | | |
|------|----------------------|------|-----------------|------|
| | SINGLE SPAN | | CONTINUOUS SPAN | |
| | 450 | 600 | 450 | 600 |
| 900 | 1.33 | 0.99 | 1.57 | 1.17 |
| 1000 | 1.02 | 0.76 | 1.27 | 0.95 |
| 1100 | 0.79 | 0.59 | 1.04 | 0.78 |
| 1200 | 0.63 | 0.47 | 0.86 | 0.64 |
| 1300 | 0.5 | 0.37 | 0.72 | 0.54 |
| 1400 | 0.40 | 0.30 | 0.61 | 0.45 |
| 1500 | 0.32 | 0.24 | 0.52 | 0.39 |
| 1600 | 0.26 | 0.19 | 0.45 | 0.33 |
| 1700 | 0.22 | 0.16 | 0.39 | 0.29 |
| 1800 | 0.18 | 0.13 | 0.34 | 0.25 |

TABLE 30: PART NO. M725: 20 x 25 x 75 x 25 x 20mm

| SPAN | M725 TOP HAT SPACING | | | |
|------|----------------------|------|-----------------|------|
| | SINGLE SPAN | | CONTINUOUS SPAN | |
| | 450 | 600 | 450 | 600 |
| 900 | 2.97 | 2.22 | 3.29 | 2.46 |
| 1000 | 2.31 | 1.73 | 2.66 | 1.99 |
| 1100 | 1.81 | 1.35 | 2.2 | 1.65 |
| 1200 | 1.44 | 1.08 | 1.85 | 1.38 |
| 1300 | 1.15 | 0.86 | 1.58 | 1.18 |
| 1400 | 0.92 | 0.69 | 1.36 | 1.02 |
| 1500 | 0.75 | 0.56 | 1.18 | 0.88 |
| 1600 | 0.6 | 0.45 | 1.03 | 0.77 |
| 1700 | 0.5 | 0.37 | 0.90 | 0.67 |
| 1800 | 0.41 | 0.3 | 0.79 | 0.59 |

NOTES:

1. NA means the maximum kPa value is less than 0.25 kPa and the Top Hat configuration is not appropriate
2. Ultimate Limit state load capacity to be calculated in accordance with AS/NZS 1170.0 or AS/NZS 1170.2 as applicable
3. Connections to be independently checked
4. Serviceability limit state to be checked separately
5. Lining contribution not included
6. Cantilever not to exceed 0.2 times the backspan

TOP HATS

Ultimate Limit State Load Tables:

0.75bmt (M) Top Hats (continued)

TABLE 31: PART NO. M735: 20 x 35 x 75 x 35 x 20mm

| SPAN | M735 TOP HAT SPACING | | | |
|------|----------------------|------|-----------------|------|
| | SINGLE SPAN | | CONTINUOUS SPAN | |
| | 450 | 600 | 450 | 600 |
| 900 | 4.97 | 3.72 | 5.26 | 3.94 |
| 1000 | 3.88 | 2.91 | 4.26 | 3.19 |
| 1100 | 3.08 | 2.31 | 3.52 | 2.64 |
| 1200 | 2.47 | 1.85 | 2.96 | 2.22 |
| 1300 | 2.00 | 1.50 | 2.52 | 1.89 |
| 1400 | 1.63 | 1.22 | 2.17 | 1.62 |
| 1500 | 1.33 | 0.99 | 1.89 | 1.41 |
| 1600 | 1.09 | 0.81 | 1.67 | 1.25 |
| 1700 | 0.89 | 0.66 | 1.45 | 1.08 |
| 1800 | 0.73 | 0.54 | 1.26 | 0.94 |

TABLE 32: PART NO. M750: 20 x 50 x 75 x 50 x 20mm

| SPAN | M750 TOP HAT SPACING | | | |
|------|----------------------|------|-----------------|------|
| | SINGLE SPAN | | CONTINUOUS SPAN | |
| | 450 | 600 | 450 | 600 |
| 900 | 8.54 | 6.4 | 8.88 | 6.66 |
| 1000 | 6.7 | 5.02 | 7.19 | 5.39 |
| 1100 | 5.34 | 4.00 | 5.94 | 4.45 |
| 1200 | 4.31 | 3.23 | 4.99 | 3.74 |
| 1300 | 3.51 | 2.63 | 4.26 | 3.19 |
| 1400 | 2.87 | 2.15 | 3.67 | 2.75 |
| 1500 | 2.36 | 1.77 | 3.2 | 2.39 |
| 1600 | 1.94 | 1.45 | 2.77 | 2.07 |
| 1700 | 1.59 | 1.19 | 2.39 | 1.79 |
| 1800 | 1.30 | 0.97 | 2.08 | 1.56 |

NOTES:

1. NA means the maximum kPa value is less than 0.25 kPa and the top hat configuration is not appropriate
2. Ultimate Limit state load capacity to be calculated in accordance with ASINZS 1170.0 or ASINZS 1170.2 as applicable
3. Connections to be independently checked
4. Serviceability limit state to be checked separately
5. Lining contribution not included
6. Cantilever not to exceed 0.2 times the backspan

Ultimate Limit State Load Tables:
1.15bmt (H) Top Hats

TABLE 33: PART NO. H515: 15 x 15 x 50 x 15 x 15mm

| SPAN | H515 TOP HAT SPACING | | | |
|-------------|----------------------|------|-----------------|------|
| | SINGLE SPAN | | CONTINUOUS SPAN | |
| | 450 | 600 | 450 | 600 |
| 900 | 1.93 | 1.44 | 2.32 | 1.74 |
| 1000 | 1.52 | 1.14 | 1.85 | 1.38 |
| 1100 | 1.22 | 0.91 | 1.51 | 1.13 |
| 1200 | 1.00 | 0.75 | 1.26 | 0.94 |
| 1300 | 0.84 | 0.63 | 1.06 | 0.79 |
| 1400 | 0.71 | 0.53 | 0.90 | 0.67 |
| 1500 | 0.60 | 0.45 | 0.78 | 0.58 |
| 1600 | 0.52 | 0.39 | 0.68 | 0.51 |
| 1700 | 0.45 | 0.33 | 0.60 | 0.45 |
| 1800 | 0.40 | 0.29 | 0.53 | 0.39 |

TABLE 34: PART NO. H525: 20 x 25 x 50 x 25 x 20mm

| SPAN | H525 TOP HAT SPACING | | | |
|-------------|----------------------|------|-----------------|------|
| | SINGLE SPAN | | CONTINUOUS SPAN | |
| | 450 | 600 | 450 | 600 |
| 900 | 4.45 | 3.33 | 5.61 | 4.2 |
| 1000 | 3.39 | 2.54 | 4.54 | 3.4 |
| 1100 | 2.61 | 1.95 | 3.67 | 2.75 |
| 1200 | 2.05 | 1.53 | 3.01 | 2.25 |
| 1300 | 1.63 | 1.22 | 2.51 | 1.88 |
| 1400 | 1.31 | 0.98 | 2.11 | 1.58 |
| 1500 | 1.08 | 0.81 | 1.80 | 1.35 |
| 1600 | 0.90 | 0.67 | 1.55 | 1.16 |
| 1700 | 0.76 | 0.57 | 1.34 | 1.00 |
| 1800 | 0.65 | 0.48 | 1.18 | 0.88 |

NOTES:

1. NA means the maximum kPa value is less than 0.25 kPa and the Top Hat configuration is not appropriate
2. Ultimate Limit state load capacity to be calculated in accordance with AS/NZS 1170.0 or AS/NZS 1170.2 as applicable
3. Connections to be independently checked
4. Serviceability limit state to be checked separately
5. Lining contribution not included
6. Cantilever not to exceed 0.2 times the backspan

TOP HATS

Ultimate Limit State Load Tables:

1.15bmt (H) Top Hats (continued)

TABLE 35: PART NO. H535: 20 x 35 x 50 x 35 x 20mm

| SPAN | H535 TOP HAT SPACING | | | |
|------|----------------------|------|-----------------|------|
| | SINGLE SPAN | | CONTINUOUS SPAN | |
| | 450 | 600 | 450 | 600 |
| 900 | 7.03 | 5.27 | 8.79 | 6.59 |
| 1000 | 5.26 | 3.94 | 6.97 | 5.22 |
| 1100 | 3.98 | 2.98 | 5.59 | 4.19 |
| 1200 | 3.03 | 2.27 | 4.56 | 3.42 |
| 1300 | 2.33 | 1.74 | 3.76 | 2.82 |
| 1400 | 1.83 | 1.37 | 3.14 | 2.35 |
| 1500 | 1.47 | 1.10 | 2.65 | 1.98 |
| 1600 | 1.20 | 0.90 | 2.25 | 1.68 |
| 1700 | 1.00 | 0.75 | 1.93 | 1.44 |
| 1800 | 0.84 | 0.63 | 1.67 | 1.25 |

TABLE 36: PART NO. H545: 20 x 45 x 50 x 45 x 20mm

| SPAN | H545 TOP HAT SPACING | | | |
|------|----------------------|------|-----------------|------|
| | SINGLE SPAN | | CONTINUOUS SPAN | |
| | 450 | 600 | 450 | 600 |
| 900 | 10.96 | 8.22 | 12.61 | 9.45 |
| 1000 | 8.42 | 6.31 | 10.22 | 7.66 |
| 1100 | 6.56 | 4.92 | 8.45 | 6.33 |
| 1200 | 5.16 | 3.87 | 7.10 | 5.33 |
| 1300 | 4.08 | 3.06 | 6.06 | 4.54 |
| 1400 | 3.25 | 2.43 | 5.16 | 3.87 |
| 1500 | 2.58 | 1.94 | 4.44 | 3.33 |
| 1600 | 2.07 | 1.55 | 3.82 | 2.86 |
| 1700 | 1.68 | 1.26 | 3.29 | 2.47 |
| 1800 | 1.38 | 1.03 | 2.85 | 2.14 |

NOTES:

1. NA means the maximum kPa value is less than 0.25 kPa and the top hat configuration is not appropriate
2. Ultimate Limit state load capacity to be calculated in accordance with ASINZS 1170.0 or ASINZS 1170.2 as applicable
3. Connections to be independently checked
4. Serviceability limit state to be checked separately
5. Lining contribution not included
6. Cantilever not to exceed 0.2 times the backspan

TABLE 37: PART NO. H550: 20 x 50 x 50 x 50 x 20mm

| SPAN | H550 TOP HAT SPACING | | | |
|-------------|----------------------|------|-----------------|-------|
| | SINGLE SPAN | | CONTINUOUS SPAN | |
| | 450 | 600 | 450 | 600 |
| 900 | 11.72 | 8.79 | 14.47 | 10.85 |
| 1000 | 8.78 | 6.58 | 11.43 | 8.57 |
| 1100 | 6.55 | 4.91 | 9.13 | 6.84 |
| 1200 | 4.89 | 3.66 | 7.39 | 5.54 |
| 1300 | 3.67 | 2.75 | 6.05 | 4.53 |
| 1400 | 2.82 | 2.11 | 4.99 | 3.74 |
| 1500 | 2.21 | 1.65 | 4.16 | 3.12 |
| 1600 | 1.77 | 1.32 | 3.48 | 2.61 |
| 1700 | 1.44 | 1.08 | 2.93 | 2.19 |
| 1800 | 1.19 | 0.89 | 2.48 | 1.86 |

TABLE 38: PART NO. H560: 20 x 60 x 50 x 60 x 20mm

| SPAN | H560 TOP HAT SPACING | | | |
|-------------|----------------------|-------|-----------------|-------|
| | SINGLE SPAN | | CONTINUOUS SPAN | |
| | 450 | 600 | 450 | 600 |
| 900 | 16.82 | 12.61 | 19.00 | 14.25 |
| 1000 | 12.93 | 9.70 | 15.40 | 11.55 |
| 1100 | 10.07 | 7.55 | 12.73 | 9.55 |
| 1200 | 7.91 | 5.93 | 10.70 | 8.03 |
| 1300 | 6.23 | 4.67 | 9.12 | 6.84 |
| 1400 | 4.92 | 3.69 | 7.87 | 5.90 |
| 1500 | 3.88 | 2.91 | 6.72 | 5.04 |
| 1600 | 3.06 | 2.30 | 5.75 | 4.31 |
| 1700 | 2.46 | 1.84 | 4.94 | 3.71 |
| 1800 | 2.00 | 1.50 | 4.27 | 3.20 |

NOTES:

1. NA means the maximum kPa value is less than 0.25 kPa and the Top Hat configuration is not appropriate
2. Ultimate Limit state load capacity to be calculated in accordance with AS/NZS 1170.0 or AS/NZS 1170.2 as applicable
3. Connections to be independently checked
4. Serviceability limit state to be checked separately
5. Lining contribution not included
6. Cantilever not to exceed 0.2 times the backspan

TOP HATS

Ultimate Limit State Load Tables:

1.15bmt (H) Top Hats (continued)

TABLE 39: PART NO. H715: 15 x 15 x 75 x 15 x 15mm

| SPAN | H715 TOP HAT SPACING | | | |
|------|----------------------|------|-----------------|------|
| | SINGLE SPAN | | CONTINUOUS SPAN | |
| | 450 | 600 | 450 | 600 |
| 900 | 2.18 | 1.63 | 2.45 | 1.83 |
| 1000 | 1.71 | 1.28 | 1.98 | 1.48 |
| 1100 | 1.37 | 1.02 | 1.64 | 1.23 |
| 1200 | 1.11 | 0.83 | 1.37 | 1.02 |
| 1300 | 0.92 | 0.69 | 1.16 | 0.87 |
| 1400 | 0.77 | 0.57 | 0.98 | 0.73 |
| 1500 | 0.65 | 0.48 | 0.85 | 0.63 |
| 1600 | 0.56 | 0.42 | 0.74 | 0.55 |
| 1700 | 0.49 | 0.36 | 0.65 | 0.48 |
| 1800 | 0.42 | 0.31 | 0.57 | 0.42 |

TABLE 40: PART NO. H725: 20 x 25 x 75 x 25 x 20mm

| SPAN | H725 TOP HAT SPACING | | | |
|------|----------------------|------|-----------------|------|
| | SINGLE SPAN | | CONTINUOUS SPAN | |
| | 450 | 600 | 450 | 600 |
| 900 | 5.45 | 4.08 | 5.86 | 4.39 |
| 1000 | 4.18 | 3.13 | 4.75 | 3.56 |
| 1100 | 3.32 | 2.49 | 3.92 | 2.94 |
| 1200 | 2.68 | 2.01 | 3.30 | 2.47 |
| 1300 | 2.19 | 1.64 | 2.81 | 2.10 |
| 1400 | 1.80 | 1.35 | 2.40 | 1.80 |
| 1500 | 1.49 | 1.11 | 2.06 | 1.54 |
| 1600 | 1.24 | 0.93 | 1.78 | 1.33 |
| 1700 | 1.04 | 0.78 | 1.56 | 1.17 |
| 1800 | 0.88 | 0.66 | 1.37 | 1.02 |

NOTES:

1. NA means the maximum kPa value is less than 0.25 kPa and the top hat configuration is not appropriate
2. Ultimate Limit state load capacity to be calculated in accordance with AS/NZS 1170.0 or AS/NZS 1170.2 as applicable
3. Connections to be independently checked
4. Serviceability limit state to be checked separately
5. Lining contribution not included
6. Cantilever not to exceed 0.2 times the backspan

TABLE 41: PART NO. H735: 20 x 35 x 75 x 35 x 20mm

| SPAN | H735 TOP HAT SPACING | | | |
|-------------|----------------------|------|-----------------|------|
| | SINGLE SPAN | | CONTINUOUS SPAN | |
| | 450 | 600 | 450 | 600 |
| 900 | 8.74 | 6.55 | 9.28 | 6.96 |
| 1000 | 6.85 | 5.13 | 7.51 | 5.63 |
| 1100 | 5.46 | 4.09 | 6.21 | 4.65 |
| 1200 | 4.40 | 3.30 | 5.22 | 3.91 |
| 1300 | 3.59 | 2.69 | 4.45 | 3.33 |
| 1400 | 2.96 | 2.22 | 3.78 | 2.83 |
| 1500 | 2.44 | 1.83 | 3.24 | 2.43 |
| 1600 | 2.01 | 1.50 | 2.79 | 2.09 |
| 1700 | 1.67 | 1.25 | 2.43 | 1.82 |
| 1800 | 1.39 | 1.04 | 2.13 | 1.59 |

TABLE 42: PART NO. H750: 20 x 50 x 75 x 50 x 20mm

| SPAN | H750 TOP HAT SPACING | | | |
|-------------|----------------------|-------|-----------------|-------|
| | SINGLE SPAN | | CONTINUOUS SPAN | |
| | 450 | 600 | 450 | 600 |
| 900 | 14.72 | 11.04 | 15.31 | 11.48 |
| 1000 | 11.55 | 8.66 | 12.40 | 9.30 |
| 1100 | 9.22 | 6.91 | 10.25 | 7.68 |
| 1200 | 7.45 | 5.58 | 8.61 | 6.45 |
| 1300 | 6.08 | 4.56 | 7.27 | 5.45 |
| 1400 | 5.00 | 3.75 | 6.16 | 4.62 |
| 1500 | 4.13 | 3.09 | 5.26 | 3.94 |
| 1600 | 3.40 | 2.55 | 4.53 | 3.39 |
| 1700 | 2.80 | 2.10 | 3.93 | 2.94 |
| 1800 | 2.30 | 1.72 | 3.43 | 2.57 |

NOTES:

1. NA means the maximum kPa value is less than 0.25 kPa and the Top Hat configuration is not appropriate
2. Ultimate Limit state load capacity to be calculated in accordance with AS/NZS 1170.0 or AS/NZS 1170.2 as applicable
3. Connections to be independently checked
4. Serviceability limit state to be checked separately
5. Lining contribution not included
6. Cantilever not to exceed 0.2 times the backspan

REVEAL BEADS

Rondo Reveal Beads are available in a variety of widths and offer a strong, straight and clean finish to window openings that require internal trimming. They are cold rolled from 0.9mm Zincaanneal steel and UV-resistant to make them strong and able to withstand harsh UV rays without cracking or breaking down.

Rondo Reveal Beads can be cut by hand with sharp shears, or with other cutting devices, such as a drop saw and installed as shown in Figure 9.

It incorporates a perforated bead leg for setting into the surrounding wall lining and can be painted over to match the wall finish.

Rondo recommends each application to be bedded in with a suitable gap-filling adhesive to the supporting framework around the window opening, whether it is masonry, timber or steel studding. A bead of paintable gap-filler can be applied to finish butt corner intersections.

In the event that a Reveal Bead requires trimming down, the cut edge can be easily finished with Rondo EXTREME® Finish Trim PLBFT30 as shown in Figure 10.

9

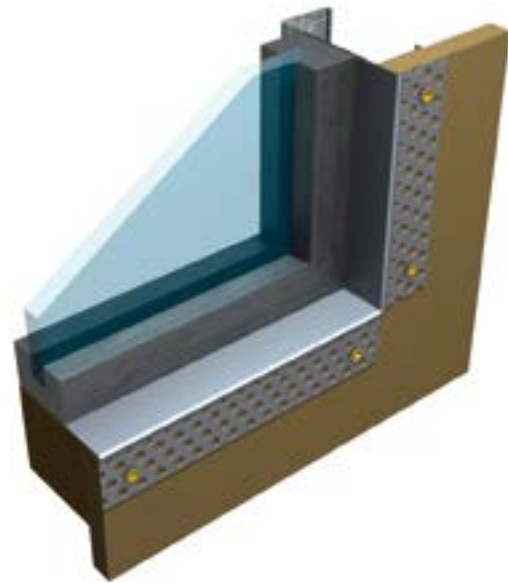

■ REVEAL BEAD INSTALLATION

10



■ REVEAL BEAD WITH FINISHING TRIM

ANGLES

Rondo has a range of Steel Angles available, including heavy duty and slotted angles.

Rondo Heavy Duty Angles are manufactured from Bluescope Steel G2 Z275 material to suit both lightweight Auto-claved Aerated Concrete Panel Systems (AAC) and steel framing requirements for façade systems.

The Heavy Duty Angles are 75 x 75mm and 100 x 100mm nominal sized and are available in 0.75 and 1.15bmt steel thicknesses, and can be used to strengthen internal corners of façade systems, in the construction of bulkhead framing or in a variety of situations requiring bracing or stiffening.

The slotted angles can be used for head and base fixing for AAC panel systems.

NOTE:

Due to their weight and subsequent OH&S handling requirements, Rondo only supplies the slotted and Heavy Duty Angles in lengths no longer than 2400mm.

11

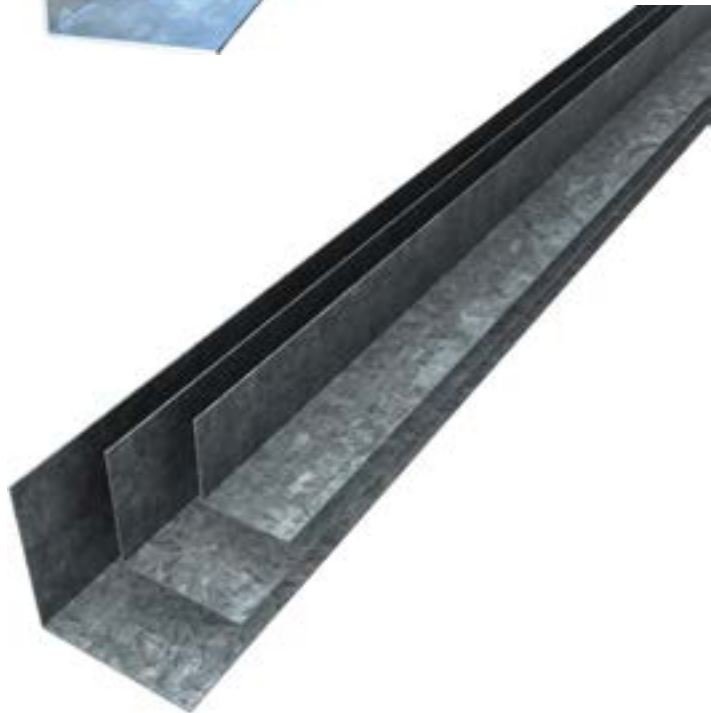

■ RONDO STEEL ANGLES

SPEEDPANEL

Rondo produces two accessories for specific use with the 78mm Speedpanel systems. Both are manufactured from G2 Z275 Blue Scope Galvabond Steel. Rondo 820 'C' Channel is 82 x 51mm nominally sized and available in 1.15bmt steel thickness and Rondo 559 90° Angle is 50 x 50mm nominally sized and available in a 1.15bmt steel thickness.

These products are made to suit the 78mm Speedpanel system specifically but Rondo is able to produce Speedpanel 'C' channels and angles to suit other sizes of speedpanel by special request.

NOTE: Please refer to the Speedpanel system literature for correct installation procedures.

RONDO ROD BENDER

The Rondo 130 Rod Bender can bend three rods to 30° at a time, and has been designed to accommodate Rondo 121 Plain Rod and 122 Threaded One End Rod – providing both onsite time and labour cost savings.

To use, first ensure tool is secure, then unscrew handle from mounting block and screw into pivot.

Rotate the handle through 180° and insert rods up to stopping block. Finally, pull the handle back in opposite direction to bend rod.

NOTE: Rondo recommends a 30° bend is applied to Rondo 121 and 122 Rod in Rondo Suspended Ceiling Systems to ensure optimum performance.



■ ROD BENDER

WARRANTY

THIS WARRANTY IS ISSUED:

TO:

PROJECT:

RONDO REF:

*This warranty is provided by:
Rondo Building Services Pty Ltd ABN 69 000 289 207
57-87 Lockwood Road, Erskine Park, NSW 2759 Australia
Tel: +61 2 9912 7300*

OTHER RIGHTS

The benefits given by this warranty are additional to other rights and remedies that you may have under laws relating to our products. Our goods come with guarantees that cannot be excluded under the Consumer Guarantees Act. You are entitled to a replacement or refund for a major failure and for compensation for any other reasonably foreseeable loss or damage. You are also entitled to have the goods repaired or replaced if the goods fail to be of acceptable quality and the failure does not amount to a major failure.

LOGGING A WARRANTY CLAIM

To make a claim under this warranty, please contact the Rondo authorised dealer or Rondo sales representative from whom you purchased the product. Otherwise, you may send details of your warranty claim directly to Rondo by post:

**Warranty Claims, Rondo Building Services,
PO Box 324, St Marys, NSW 1790 Australia**

All claims must be received by Rondo within the applicable warranty period. Once your claim is received, a representative of Rondo will determine whether your warranty claim is valid and, if it is, will inform you how Rondo will honour it. Any costs you incur in making this warranty claim are your responsibility and not covered by this warranty.

After you lodge a warranty claim, Rondo may, before providing warranty service, require that you provide proof of purchase, respond to questions designed to assist with diagnosing potential faults and follow Rondo's procedures for obtaining warranty service. You must respond to all requests promptly and at your own expense.

GENERAL WARRANTY STATEMENT

Rondo Building Services Pty Ltd (Rondo) warrants all Rondo branded products against defects in materials under normal use for the period from the date of purchase specified below:

- All Rondo products: ten (10) years, with the exception of
- Rondo EXTREME® PVC Finishing Sections: fifteen (15) years.

In addition, Rondo warrants that the Rondo KEY-LOCK® and DUO® Suspended Ceiling Systems will remain structurally sound for a period of fifteen (15) years from the date of purchase.

If you submit a valid claim under this warranty, Rondo will, at its option:

- (i) repair the product;
- (ii) replace the product with a product that is at least equivalent to the original product in function and quality; or
- (iii) refund the purchase price. When a product or component is replaced or refunded, any replacement item becomes your property and the replaced item becomes Rondo's property.

This warranty is subject to the exclusions and conditions below. Where an additional warranty has been issued by Rondo, the terms of that additional warranty prevail to the extent of any inconsistency.

WARRANTY EXCLUSIONS

This warranty does not apply to products that:

- Have not been purchased from Rondo or a Rondo authorised dealer;
- Have been modified or changed without approval from Rondo; or
- Have not been installed in accordance with Rondo's then current installation guidelines (such as spacing, allowable loads and the like) and environment specifications (including outdoor use of products designed for indoor use only).

This warranty does not apply to damage caused by:

- The fitting or use of components not supplied by Rondo;
- Repair, maintenance or service by a person not authorised by Rondo;
- Fasteners that do not have durability and corrosion resistance at least equal to the product that they are fastening (e.g. the use of non-stainless steel fasteners with a stainless steel bead);
- Normal wear and tear.

SPECIAL CONDITIONS FOR OUTDOOR USE

The only Rondo metal products that are designed and warranted for outdoor use are the following products in the Rondo EXANGLE® Range: EP32, EP50, EP17, ER11, P01S & SR02. Whilst these products have been coated with a highly effective corrosion resistant material, or made with corrosive resistant stainless steel, the products may still be susceptible to corrosion in highly aggressive environments. The use of the below products is not recommended, and this warranty does not apply, in the following applications:

| EP32, EP50, EP17, ER11 | SR02, P01S |
|---|--|
| <ul style="list-style-type: none"> • Within 1km of breaking surf. • Within 100m of calm, open saltwater locations (e.g. harbours). • Within 500m of areas of heavy industrial emissions. | <ul style="list-style-type: none"> • Within 100m of breaking surf. • Within 100m of heavy industrial emissions, or fossil fuel combustion. |
| <ul style="list-style-type: none"> • Areas exposed to prevailing winds that contain salt or regular industrial emissions. • Where continuous or cyclical moisture is present, such as retaining walls, planter boxes or garden beds unless protective waterproofing measures have been applied in accordance with Rondo's published specifications. • Environments which contain bore water or soils with high chloride content. | |

ADDITIONAL WARRANTY COVERAGE & CONDITIONS

.....
.....
.....

AUTHORISED BY

SIGNED **DATE**