

RESIDENTIAL SLIMCLAD WALL CLADDING

JAMB FLASHING FOR VERTICAL CLADDING ON CAVITY (RECESSED WINDOW/DOOR OPTION 3)

Detail Number: RI-RSCW012B-3

Date drawn: 06/09/2021

Scale: 1 : 5 @ A4

DETAIL ANNOTATION:

1. REFER TO E2/AS 1 FOR GENERAL WINDOW OPENING FOR WRAPPING OF FRAMED OPENING PRIOR TO WINDOW INSTALLATION.
2. WINDOW PROFILE TO BE SELECTED TO ACHIEVE COVER SHOWN IN DETAILS.
3. ARCHITRAVE'S ARE SHOWN FOR CONSISTENCY ONLY, DETAIL MAY BE USED WITH REBATED LINER.
4. WHERE SUPPORT BRACKETS ARE REQUIRED BY THE WINDOW MANUFACTURER TO CARRY THE FRAME AND GLAZING LOADS THEY MUST BE SUPPLIED AS AN INTEGRAL PART OF THE WINDOW MANUFACTURER'S RECOMMENDATIONS.
5. LIASE WITH WINDOW MANUFACTURER PRIOR TO INSTALLATION.
6. CAVITY BATTENS CONTAINING CORROSIVE MATERIAL MUST BE SEPARATED FROM METAL CLADDING BY DPC, BUILDING WRAP, PVC OR PAINTING
7. CASTELLATED BATTEN, DRAINAGE PLASTIC BATTEN OR APPROVED DRAINED BATTEN CAN BE USED WITH THIS SYSTEM.
8. FASTENERS TO BE COMPATIBLE WITH MATERIAL BEING FIXED AND THE SUITABLE GRADE FOR THE ENVIRONMENT IN WHICH LOCATED
9. ALTERNATIVELY REFER TO E2/AS 1 FOR FLASHING COVER GUIDANCE

BUILDING WRAP DRESSED INTO OPENING AS PER E2/AS 1

ROOFING INDUSTRIES BACK TRAY* FLASHING RUN FROM TOP OF HEAD FLASHING TO GROUND OR EXIT POINT

HORIZONTAL DRAINED BATTEN (7)

ROOFING INDUSTRIES 'SLIMCLAD' PROFILED METAL CLADDING

SCREW FIXING (8)

ROOFING INDUSTRIES JAMB FLASHING

CONTINUOUS COMPRESSIBLE FOAM SEAL

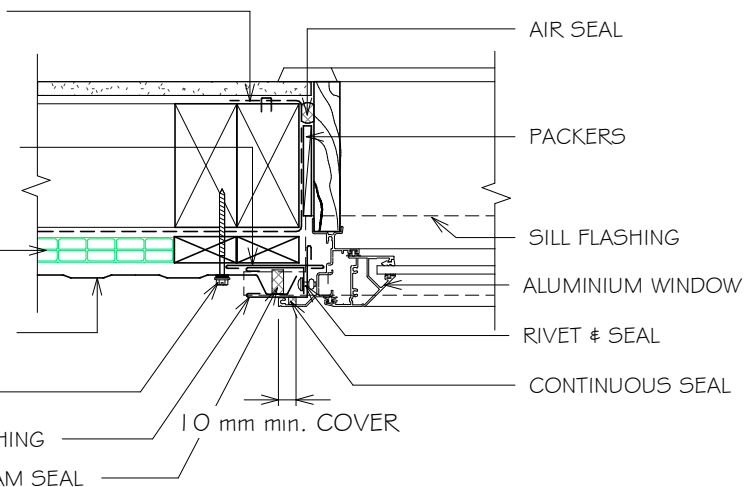

JAMB FLASHING ON CAVITY

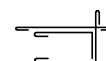

SLIMCLAD IS OUTSIDE THE SCOPE OF E2/AS 1 BUT MAYBE APPLICABLE FOR NON RESIDENTIAL BUILDINGS OR AS AN ALTERNATIVE SOLUTION

* Back tray size may require to increase to ensure coverage at ends of head flashing. Turn down end of head flashing

REFERENCE FLASHINGS: NZ METAL ROOF AND WALL CLADDING CODE OF PRACTICE AND/OR E2/AS 1

GENERAL NOTES:

- These details are to be read with Roofing Industries profile technical summary regarding wind loads and fixings.
- These details are generally in compliance with E2/AS 1 and/or the NZ Metal Roof & Wall Cladding Code of Practice and in some cases specific details by 'Roofing Industries'.
- The building designer is ultimately responsible to ensure that details used meet the requirements of the NZ Building Code for the specific project.
- Details of the supporting structure including cavity battens are indicative only and are the responsibility of the building designer. For steel framed buildings thermal break cavity battens may be required.
- Roof/wall underlay selection are the responsibility of the designer. Underlay to be installed in accordance with underlay manufacturer's recommendations and requirements.
- These details are for Roofing Industries profile/s as nominated and may not be applicable to other profiles.
- This drawing is the copyright of 'Roofing Industries' and can only be copied or reproduced with their permission.
- Further information can be obtained from the NZ Metal Roof & Wall Cladding Code of Practice: www.metalroofing.org.nz or E2/AS 1.
- Details are for steel based materials, other substrates may require some changes.
- All dimensions are nominal.

Copyright detail © 2021

