



# FANS



**VENTÜER**  
Engineered Ventilation Products & Systems



*While we have made every attempt to ensure that the information contained in this document is accurate, Ventüer is not responsible for any errors or omissions, or for the results obtained from the use of the information. Due to a policy of continuous development and improvement, the right is reserved to supply products which may differ slightly from those described in this document.*

# OUR MISSION

**To supply engineered ventilation products and systems that enable our clients to create healthy, comfortable and code-compliant buildings.**

Ventilation of indoor spaces has never been more important, with an increasing percentage of the world's population spending more time living, working and playing indoors.

***Recognising the need for ventilation is easy. Delivering products and systems that create a healthy and comfortable indoor environment, comply with building code requirements, and work with the other building elements is not.***

Ventüer works with architects, builders and installation contractors. Since 2009 we have been designing, manufacturing and guaranteeing ventilation products and systems for a wide range of commercial, industrial and residential construction projects.

When partnering with Ventüer, you can have confidence that the ventilation products and systems provided to your construction project are well designed, fit for purpose and code-compliant. We eliminate the risks associated with incorrect product selection or poor installation methodology, leaving you with high performing buildings that deliver health, comfort and safety to their occupants.

---

***We take the responsibility, the risk and the care.***

***You take the credit for the successful end result.***

---

# RANGE OVERVIEW

FANS



## Inline Mixed Flow Fans

The Blauberg "Turbo" inline mixed-flow fans by Ventüer are versatile, high performing duct fans. With models to suit duct sizes from 100mm to 315mm, these fans are suitable for the ventilation of bathrooms, toilets, ensuites, laundries and kitchen in homes, hotels, apartments and commercial buildings.

[Page 6]

## Inline Silenced Mixed Flow Fans

Constructed with an integral acoustic outer layer and specially designed mixed-flow blades, the Blauberg "Iso-Mix" silent mixed-flow fans by Ventüer offer high pressure airflow rates while generating minimal noise. Designed for use in residential and office ventilation situations where noise control is important.

[Page 8]



## Inline Axial Fans

Designed for residential exhaust or supply systems, the Blauberg "Ducto" fans by Ventüer are low noise axial fans compatible with 100mm, 125mm and 150mm ducts. Quiet and energy efficient, they are suited to short duct runs with low air resistance. Available as both fans only and as complete kits with duct and grilles.

[Page 10]

## Wall & Ceiling Mounted Exhaust Fans

Featuring a minimalistic and unobtrusive decorative front panel, the Blauberg "Quatro" exhaust fans by Ventüer are suitable for both wall and ceiling mounting. Complete with integral backdraft damper, ball bearing motor and low noise impeller, they offer easy maintenance and quiet operation.

[Page 12]



## Roof Mounted Fans

The through-roof fan kits by Ventüer are available for both supply and exhaust scenarios. Complete with high quality aluminium cowl, HDPE tube and roof flashing.

[Page 13]

## Axial Plate Fans

The Ventüer square plate recessed fans are a compact, reliable, external rotor motor fan with wire grill and internal cowl mount plate. Sickle fan blades are black coated steel for efficient low noise operation in a wide range of applications.

[Page 14]







# Inline Mixed Flow Fans

## USE

- Supply and extraction ventilation of offices, bathrooms, toilets, laundries, kitchens, ensuites in apartments, hotels, homes and commercial buildings.
- Ventilation air ducts requiring high pressure, powerful air flow and low noise level.
- Compatible with Ø 100 up to 315 mm round air ducts.

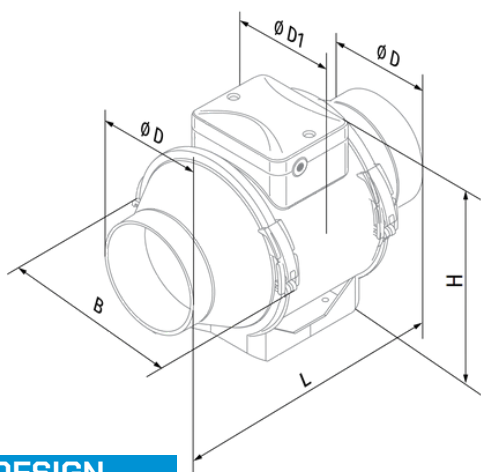

## OVERALL DIMENSIONS (MM)

Model	Ø D	Ø D1	B	H	L	Weight (kg)
Turbo-100	96	164	167	190	246	1.45
Turbo-125	123	164	167	190	246	1.79
Turbo-150	148	187	220	251	289	3.18
Turbo-200	199	209	239	261	295.5	3.8
Turbo-250	247	257	287	323	383	7.83
Turbo-315	310	323	362	408	445	11.7

## DESIGN

- The casing is made of low flammable polypropylene.
- Ventilation unit with terminal box. Can be turned to any position.
- Special design of the casing permits easy dismantling of the impeller and motor block for fan servicing without dismantling the air duct.

## MOTOR

- 220–240 V single phase at 50 Hz.
- All motors have a sealed ball bearing motor with a service life of up to 40,000 hours, are 2 speed with an exterior two speed switch.
- All motors have manual reset thermal overload protection as required for inline duct fans AS/NZS60335-2-80:2004.
- 100 mm & 125 mm fans cannot be speed controlled.

## WIRING

- Comes with a 1.2 m lead, 2 pin plug and external two speed switching.
- Timer fans come with a 1.2 m lead, 4 pin plug and external two speed switching.

## MOUNTING

- Due to the compact design the fan is the ideal solution for mounting in limited spaces, including space behind a false ceiling.
- The fan can be installed in any section of the ventilation system from intake to the end of the duct work.
- Wall or ceiling mounting with a mounting plate.

## TECHNICAL DATA

Parameters	Turbo-100		Turbo-125		Turbo-150		Turbo-200		Turbo-250		Turbo-315	
	min	max	min	max	min	max	min	max	min	max	min	max
Speed												
Voltage [V]	230	230	230	230	230	230	230	230	230	230	230	230
Frequency [Hz]	50/60	50/60	50/60	50/60	50/60	50/60	50/60	50/60	50/60	50/60	50/60	50/60
Power [W]	21	33	23	37	42	50	76	108	125	177	227	315
Current [A]	0.11	0.21	0.18	0.27	0.19	0.22	0.34	0.48	0.54	0.79	0.99	1.42
Maximum air flow [m³/h]	145	187	220	280	430	560	805	1080	1070	1360	1420	1750
RPM [min <sup>-1</sup> ]	2180	2385	1950	2455	1940	2620	1915	2380	1955	2440	2115	2505
Sound pressure level at 3 m [dBA]	33	38	34	39	38	48	45	50	52	58	52	60
Max. transported air temperature [°C]	+60		+60		+60		+60		+60		+60	
SEC class	C		B		B		B		-		-	
IP rating	IPX4		IPX4		IPX4		IPX4		IPX4		IPX4	
Motor IP rating	IPX4		IPX4		IPX4		IPX4		IPX4		IPX4	
ErP	-		-		2018		2018		2018		2018	

### TURBO-100

Sound power level, A-weighted	Total	Octave frequency bands [Hz]								LpA 3 m	LpA 1 m
		63	125	250	500	1000	2000	4000	8000		
<b>Min speed</b>											
LwA to inlet [dBA]	54	19	35	50	49	44	37	25	17	33	43
LwA to outlet [dBA]	53	17	34	50	49	48	36	24	17	32	42
LwA to env. [dBA]	47	14	29	43	43	39	33	22	15	27	37
<b>Max speed</b>											
LwA to inlet [dBA]	59	24	34	53	54	53	48	37	26	38	48
LwA to outlet [dBA]	57	23	33	52	52	52	47	37	26	37	47
LwA to env. [dBA]	52	18	29	46	48	47	43	33	23	32	42

### TURBO-125

Sound power level, A-weighted	Total	Octave frequency bands [Hz]								LpA 3 m	LpA 1 m
		63	125	250	500	1000	2000	4000	8000		
<b>Min speed</b>											
LwA to inlet [dBA]	54	26	38	52	50	44	38	27	17	34	44
LwA to outlet [dBA]	54	25	37	51	49	43	38	28	18	33	43
LwA to env. [dBA]	49	21	32	46	45	40	35	25	16	29	39
<b>Max speed</b>											
LwA to inlet [dBA]	60	20	31	57	51	51	50	39	27	39	49
LwA to outlet [dBA]	59	20	31	56	51	51	49	39	26	38	48
LwA to env. [dBA]	54	16	27	51	46	47	45	36	24	34	44

### TURBO-150

Sound power level, A-weighted	Total	Octave frequency bands [Hz]								LpA 3 m	LpA 1 m
		63	125	250	500	1000	2000	4000	8000		
<b>Min speed</b>											
LwA to inlet [dBA]	59	31	45	54	52	54	48	35	29	38	48
LwA to outlet [dBA]	63	37	49	56	56	60	48	39	30	42	52
LwA to env. [dBA]	52	21	30	48	48	45	42	34	23	32	42
<b>Max speed</b>											
LwA to inlet [dBA]	69	38	51	57	62	60	66	49	44	48	58
LwA to outlet [dBA]	72	42	55	66	67	68	65	53	45	52	62
LwA to env. [dBA]	65	23	37	56	59	57	61	47	35	44	54

### TURBO-200

Sound power level, A-weighted	Total	Octave frequency bands [Hz]								LpA 3 m	LpA 1 m
		63	125	250	500	1000	2000	4000	8000		
<b>Min speed</b>											
LwA to inlet [dBA]	66	38	50	58	59	60	59	55	45	45	55
LwA to outlet [dBA]	64	40	50	54	58	59	57	51	44	43	53
LwA to env. [dBA]	60	27	42	49	54	55	54	46	34	39	49
<b>Max speed</b>											
LwA to inlet [dBA]	71	41	50	63	64	65	64	62	52	50	60
LwA to outlet [dBA]	70	43	52	61	66	64	63	58	51	50	60
LwA to env. [dBA]	65	34	43	54	60	60	60	53	41	45	55

### TURBO-250

Sound power level, A-weighted	Total	Octave frequency bands [Hz]								LpA 3 m	LpA 1 m
		63	125	250	500	1000	2000	4000	8000		
<b>Min speed</b>											
LwA to inlet [dBA]	72	48	57	63	66	69	64	54	45	52	62
LwA to outlet [dBA]	75	48	56	64	70	71	66	56	45	54	64
LwA to env. [dBA]	65	32	51	57	61	59	56	45	32	44	54
<b>Max speed</b>											
LwA to inlet [dBA]	78	52	62	66	71	75	72	62	52	58	68
LwA to outlet [dBA]	81	52	60	66	76	77	74	63	52	60	70
LwA to env. [dBA]	72	35	50	63	69	66	63	53	40	51	61

### TURBO-315

Sound power level, A-weighted	Total	Octave frequency bands [Hz]								LpA 3 m	LpA 1 m
		63	125	250	500	1000	2000	4000	8000		
<b>Min speed</b>											
LwA to inlet [dBA]	72	43	54	62	67	66	67	58	47	52	62
LwA to outlet [dBA]	70	45	57	59	64	66	63	56	46	50	60
LwA to env. [dBA]	62	28	51	53	57	57	54	46	36	41	51
<b>Max speed</b>											
LwA to inlet [dBA]	80	50	59	68	73	77	74	70	59	60	70
LwA to outlet [dBA]	78	51	60	66	70	75	71	66	57	58	68
LwA to env. [dBA]	72	37	51	66	66	67	65	58	48	52	62

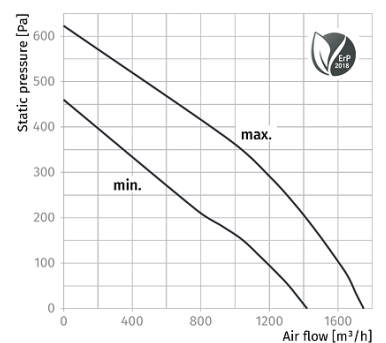
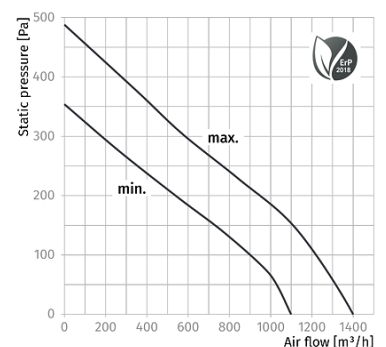
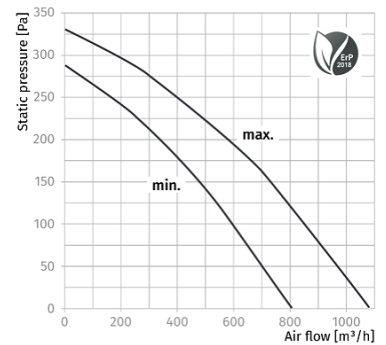
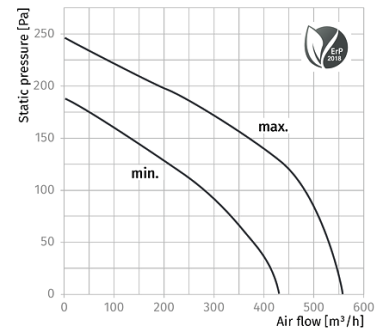
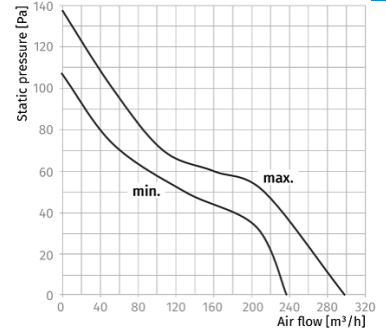
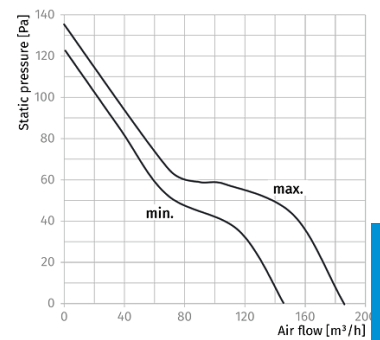

# Sound Insulated Inline Mixed Flow Fans



FANS

## USE

- Supply and extract ventilation systems installed in various premises requiring low noise level.
- Ventilation air ducts requiring high pressure, powerful air flow and low noise level.
- Compatible with Ø 100 up to 315 mm round air ducts.

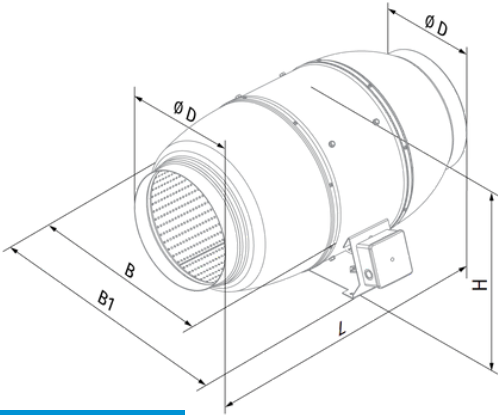

## OVERALL DIMENSIONS (MM)

Model	Ø D	B	B1	L	H	Weight (kg)
Iso-Mix 150	148	247	273	579	263	6.1
Iso-Mix 200	198	293	386	550	295	8
Iso-Mix 250	248	358	445	658	360	15
Iso-Mix 315	313	432	520	780	434	25

## DESIGN

- The casing is made of polymer coated steel, internally filled with 50 mm mineral wool thermal- and sound-insulating layer.
- Special inner perforation of the casing and sound insulating material are designed for wide frequency sound absorbing.
- Mixed flow impeller made of high quality plastic.
- The diffuser, the specially profiled impeller and directing vanes provide high performance and powerful pressure combined with low noise operation.
- External airtight terminal block on the fan casing for power supply.
- Mounting brackets on the fan casing for mounting to the floor, to the wall or ceiling.

## WIRING

- Comes with a 1.2 m lead, 2 pin plug and external two speed switching.

## MOTOR

- 220-240 V single phase at 50 Hz.
- All motors have a sealed ball bearing motor with a service life of up to 40 000 hours, are 2 speed with an exterior two speed switch and can be fitted with a speed controller.
- All motors have manual reset thermal overload protection as required for inline duct fans AS/NZS60335-2-80:2004.

## MOUNTING

- Due to the compact design the fan is the ideal solution for mounting in limited spaces, including space behind a false ceiling.
- The fan can be installed in any section of the ventilation system from intake to the end of the duct work.

## TECHNICAL DATA

Parameters	Iso-Mix 150		Iso-Mix 200		Iso-Mix 250		Iso-Mix 315	
	min	max	min	max	min	max	min	max
Speed								
Voltage [V]	230	230	230	230	230	230	230	230
Frequency [Hz]	50/60	50/60	50/60	50/60	50/60	50/60	50/60	50/60
Power [W]	45	52	78	110	127	178	230	330
Current [A]	0.2	0.23	0.35	0.49	0.52	0.79	0.93	1.41
Maximum air flow [m³/h]	410	550	790	1035	1035	1315	1510	1920
RPM [min <sup>-1</sup> ]	1985	2640	2000	2460	1960	2460	2120	2620
Sound pressure level at 3 m [dBA]	38	43	41	44	45	49	46	49
Max. transported air temperature [°C]		+60		+60		+60		+60
SEC class		C		C		-		-
IP rating		IPX4		IPX4		IPX4		IPX4
Motor IP rating		IPX4		IPX4		IPX4		IPX4
ErP		2018		2018		2018		2018



### ISO-MIX 150

Sound power level, A-weighted	Total	Octave frequency bands [Hz]								LpA 3 m	LpA 1 m
		63	125	250	500	1000	2000	4000	8000		
<b>Min speed</b>											
LwA to inlet [dBA]	59	32	49	55	53	52	38	28	15	38	48
LwA to outlet [dBA]	62	36	41	44	61	53	44	44	29	41	51
LwA to env. [dBA]	47	37	40	41	40	38	29	22	19	26	36
<b>Max speed</b>											
LwA to inlet [dBA]	63	34	53	60	57	56	41	30	17	43	53
LwA to outlet [dBA]	64	37	42	46	64	56	46	46	30	44	54
LwA to env. [dBA]	53	44	47	48	47	45	34	26	23	33	43

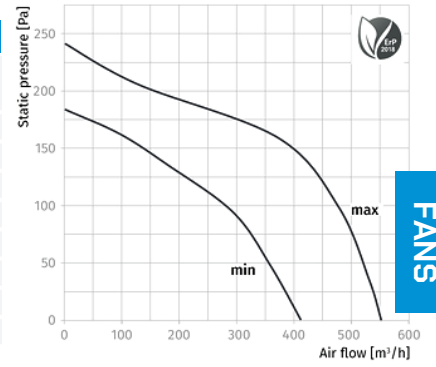

FANS

### ISO-MIX 200

Sound power level, A-weighted	Total	Octave frequency bands [Hz]								LpA 3 m	LpA 1 m
		63	125	250	500	1000	2000	4000	8000		
<b>Min speed</b>											
LwA to inlet [dBA]	61	33	52	58	55	54	39	30	16	41	51
LwA to outlet [dBA]	61	42	45	52	55	57	52	45	35	40	50
LwA to env. [dBA]	51	40	46	46	44	41	37	35	30	31	41
<b>Max speed</b>											
LwA to inlet [dBA]	65	35	55	61	59	57	42	31	17	44	54
LwA to outlet [dBA]	66	38	44	48	66	57	48	48	31	46	54
LwA to env. [dBA]	57	44	52	52	49	45	41	39	34	36	46

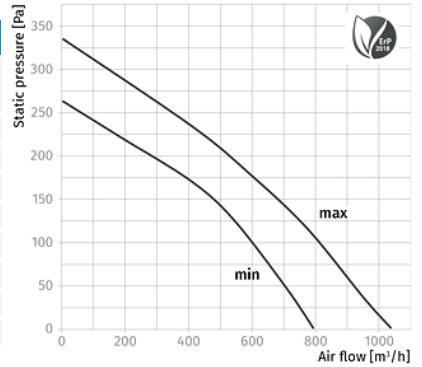

### ISO-MIX 250

Sound power level, A-weighted	Total	Octave frequency bands [Hz]								LpA 3 m	LpA 1 m
		63	125	250	500	1000	2000	4000	8000		
<b>Min speed</b>											
LwA to inlet [dBA]	66	36	56	63	60	59	43	32	17	45	55
LwA to outlet [dBA]	64	37	42	46	63	55	46	46	30	43	53
LwA to env. [dBA]	55	44	48	51	47	44	37	31	25	34	44
<b>Max speed</b>											
LwA to inlet [dBA]	69	38	59	66	63	62	45	34	18	49	59
LwA to outlet [dBA]	75	43	50	54	74	65	54	54	36	54	64
LwA to env. [dBA]	58	47	49	53	53	49	44	39	31	38	48

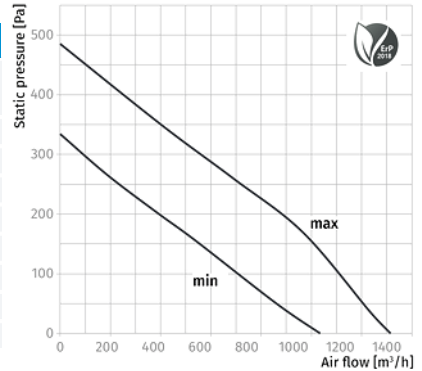

### ISO-MIX 315

Sound power level, A-weighted	Total	Octave frequency bands [Hz]								LpA 3 m	LpA 1 m
		63	125	250	500	1000	2000	4000	8000		
<b>Min speed</b>											
LwA to inlet [dBA]	67	36	57	63	61	59	43	32	18	46	56
LwA to outlet [dBA]	71	50	54	62	66	67	62	54	42	51	61
LwA to env. [dBA]	56	47	47	52	50	45	41	37	29	36	46
<b>Max speed</b>											
LwA to inlet [dBA]	70	38	60	67	64	62	45	34	18	49	59
LwA to outlet [dBA]	75	53	56	66	69	71	66	56	44	54	64
LwA to env. [dBA]	60	51	52	54	55	50	46	43	35	40	50

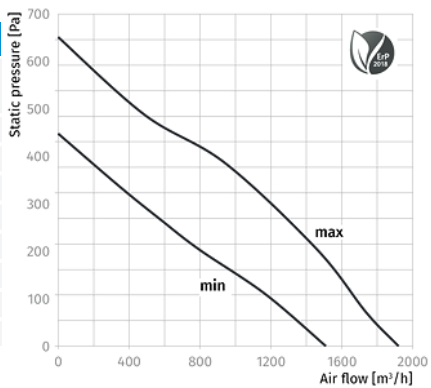

# Inline Axial Fans



## USE

- Low noise axial inline fans for exhaust or supply ventilation with superior capacity up to 340 m<sup>3</sup>/h.
- Designed for PVC ducting systems or flexible ducts.
- From low to medium air flow motion for short distances at low air resistance.
- Compatible with Ø 100, 125 and 150 mm air ducts.

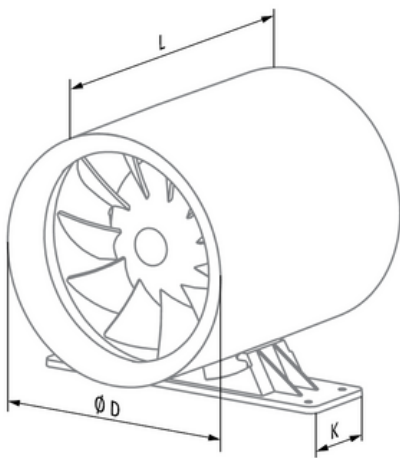

## OVERALL DIMENSIONS (MM)

Model	Ø D	L	K	Weight [kg]
Ducto-100	100	137.5	53.5	0.61
Ducto-125	125	161.5	53.5	0.75
Ducto-150	150	181.5	53.5	1.3

## DESIGN

- The casing and the impeller are made of high quality durable plastic.
- Specially designed mixed flow impeller profile ensures high air flow and low noise level.
- Low energy usage from 7.5 W.
- The models of Blauberg Ducto Series are equipped with a single-phase motor.
- The motor has thermal overheating protection for motor overload prevention.
- Motor on special anti-vibration connectors.

## CONTROL

- Manual speed control with a room light switch. It is not included in the delivery package.
- Smooth speed control available with a thyristor speed controller (not included as standard).
- Several fans may be connected to the same controller. The models with timer are not compatible with a speed controller.

## WIRING

- Comes with a 1.2 m lead, 2 pin plug.

## MOUNTING

- The fan is mounted into a matching duct size. Fastening with clamps in case of flexible duct connection.
- The mounting bracket enables installation of the fan on horizontal and vertical flat surfaces.
- Two fans can be installed in series for higher operation pressure.

## TECHNICAL DATA

Parameters	Ducto-100	Ducto-125	Ducto-150
Voltage [V]	220-240	220-240	220-240
Frequency [Hz]	50	50	50
Power [W]	7.5	13	22
Current [A]	0.049	0.085	0.095
Maximum air flow [m <sup>3</sup> /h]	110	215	340
RPM [min <sup>-1</sup> ]	2100	2250	2250
Noise level [dBA]	25	33	39

FANS

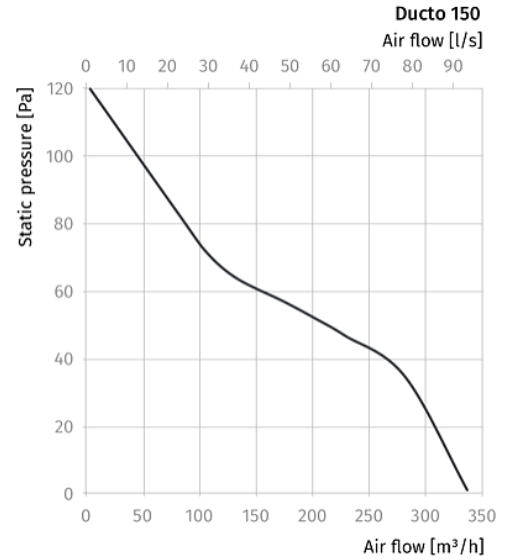
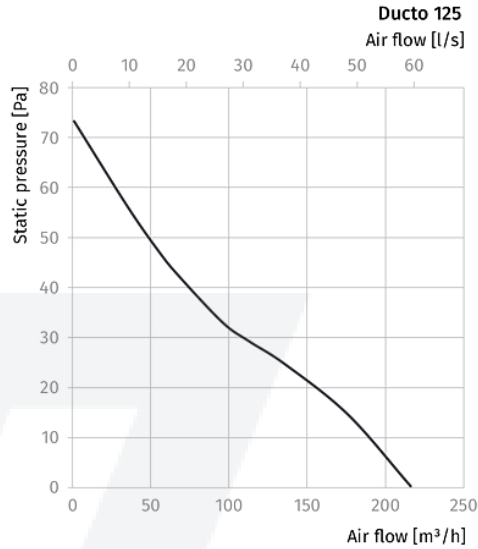
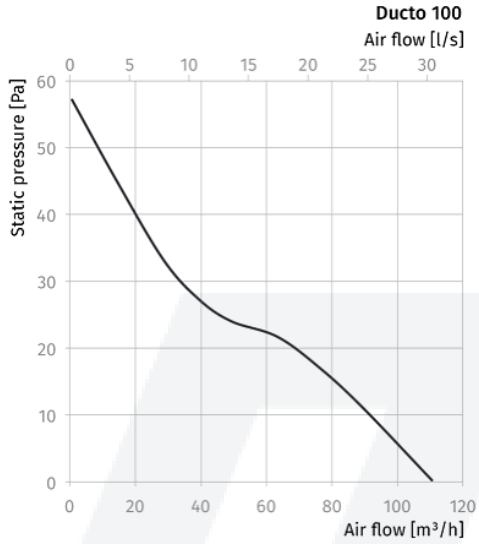

### DUCTO KIT

- The Ducto loft mounted extractor fan kit is an all in one extraction system for exhaust ventilation of bathrooms, showers, wet rooms and other utility spaces.
- Consists of: Ducto 150 fan, flexible air duct 10 metre, internal round plastic grille, external square plastic grille, adhesive tape.



# Wall Mounted Fans

FANS



## FEATURES

- Wall and ceiling mounting.
- Easy maintenance.
- Low noise impeller.
- Continuous operation.
- Backdraft damper.
- Ball bearing motor.
- 5 year warranty.

## OVERALL DIMENSIONS (MM)

Model	a	a1	b	c	∅ d	e
Quatro-150	236	207	165	157	150	38

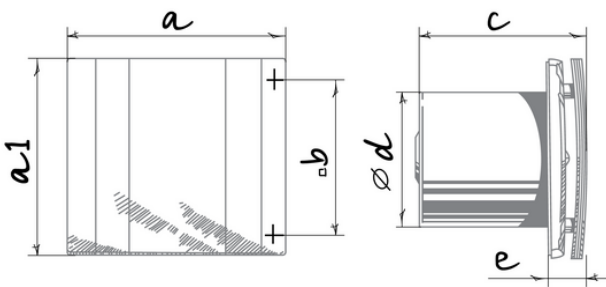

## TECHNICAL DATA

Parameters	Quatro-150
Voltage [V]	220-240
Power [W]	24
Current [A]	0.13
Maximum air flow [m³/h]	265
RPM [min⁻¹]	2400
Noise level [dBA]	37

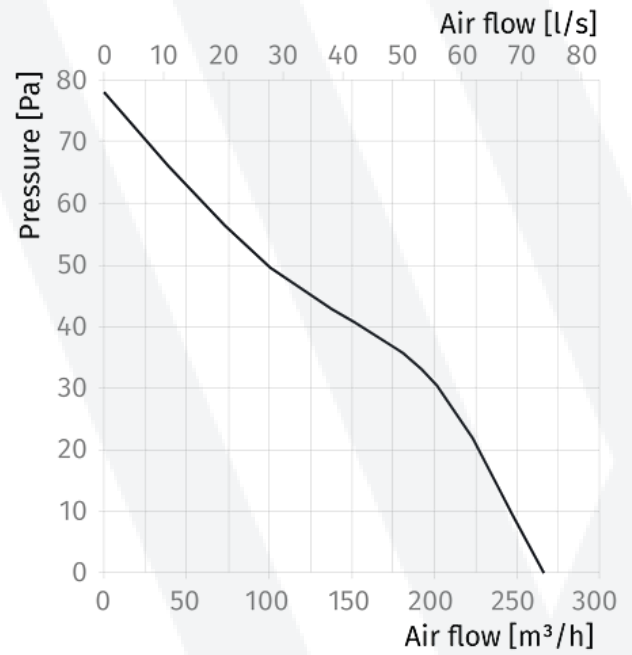

## MOUNTING

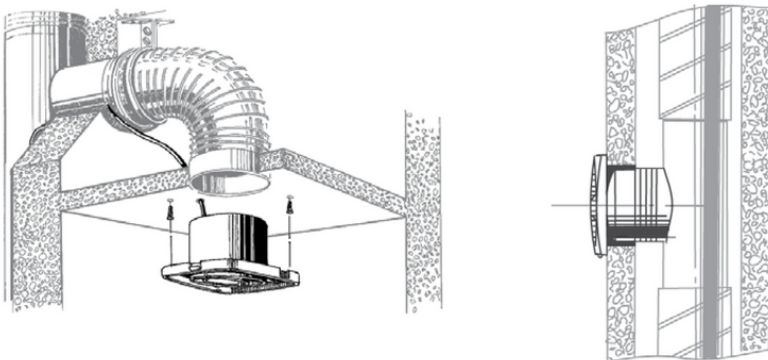

# Roof Mounted Fan Kits



## FEATURES

- Through roof fan kits for supply and extract scenarios.
- Centrifugal and axial fan options.
- High quality aluminium cowl construction which incorporates fan for longevity of operation.
- Includes roof flashing for metal based roofs
- 220-240 V single phase fan motors, which come with 0.7m lead and two pin plug.
- Kits include HPDE tube, metal roof flashing and mounting straps.

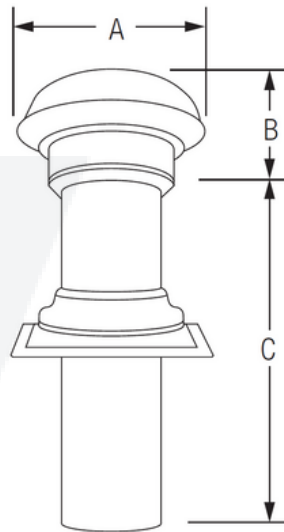

## DIMENSIONS (MM)

Model	A	B	C
0530	275	170	500
0967			
0532			
0740			
0739			
0534			

## TECHNICAL DATA

Model	Air Direction	Duct Size [mm]	Fan Type	Power (W)	Max. Fan Pressure (Pa)	Max Air Flow [M <sup>3</sup> /H]	Sound (dBA)
0530	Extraction	150	Centrifugal	70	320	153	62
0967	Extraction	150	Centrifugal [3 speed]	70	320	153	62
0532	Extraction	150	Axial	18	91	105	38
0740	Extraction	150	Centrifugal	70	320	153	62
0739	Extraction	150	Axial	18	91	105	38
0534	Supply	150	Axial	18	91	105	38

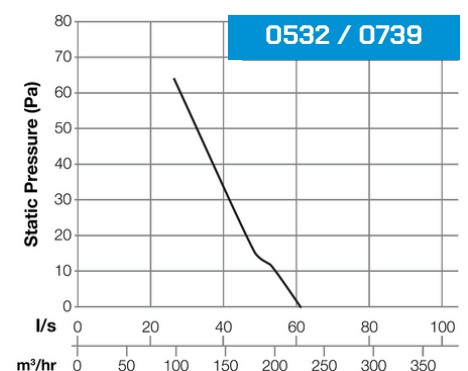
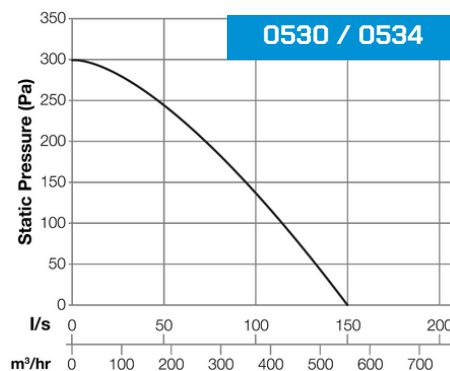
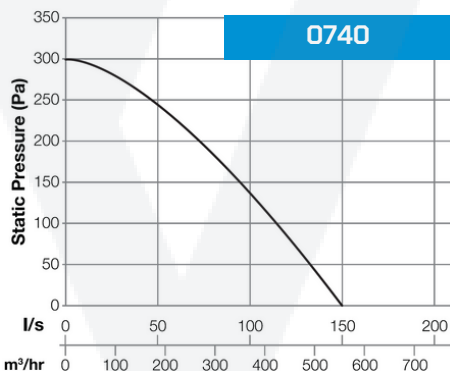



# Axial Plate Fans



## FEATURES

- External rotor motor fan with wire grill and internal cowl mounting plate.
- Black powdercoated steel blades designed for low noise operation.
- IP54 Motor Protection
- Wide range of models with options for forced [F] or induced [A] air flow directions.

## APPLICATIONS

- Ventilation
- Evaporators
- Condensers
- Chillers
- Water coolers

## OVERALL DIMENSIONS (MM)

Model	A	B	C	D	E	F
K4M-250	50	79	260	280	320	370
K4M-300	63	90	315	355	380	430
K4M-350	70	119	360	380	435	485
K4M-400	83	132	410	430	490	540
K4M-450	90	145	460	480	520	575
K4M-500	106	149	510	630	615	665

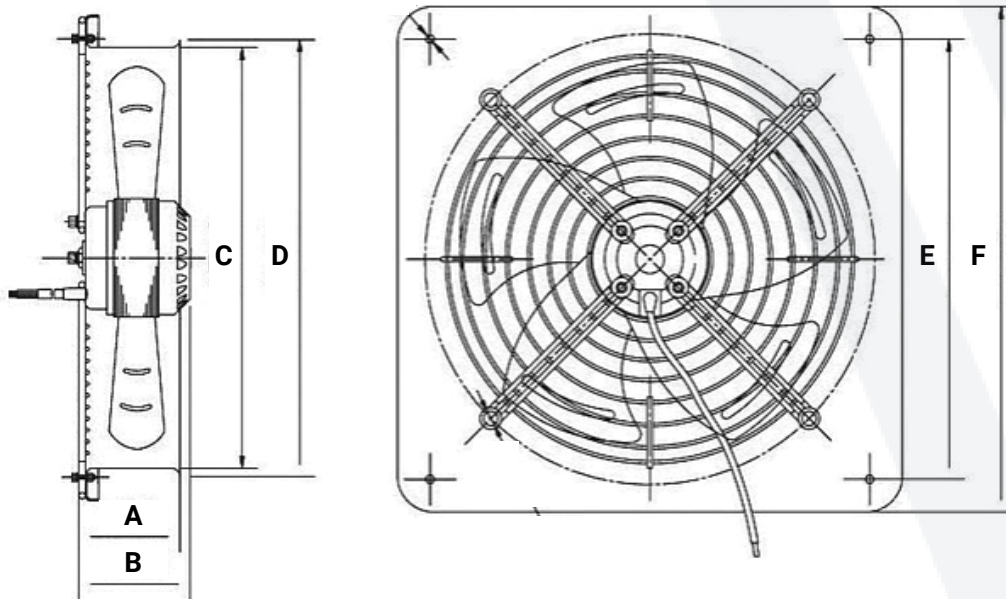

Air Flow Direction

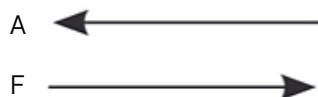

# TECHNICAL DATA

Model	Blade Diameter	Power [W]	Current [A]	Speed [RPM]	Max. Air Flow [M <sup>3</sup> /H]	Max. Fan Pressure [Pa]	Air Flow Direction
K2M250-30FPF	250	100	0.45	2480	775	90	F
K2M250-30APF	250	100	0.45	2480	775	90	A
K4M250-30FPF	250	100	0.45	1400	440	45	F
K4M250-30APF	250	100	0.45	1400	440	45	A
K4M300-30FPF	300	90	0.42	1350	1400	80	F
K4M300-30APF	300	90	0.42	1350	1400	80	A
K4M350-30FPF	350	135	0.6	1400	2700	135	F
K4M350-30APF	350	135	0.6	1400	2700	135	A
K4M400-30FPF	400	190	0.9	1350	3850	94	F
K4M400-30APF	400	190	0.9	1350	3850	94	A
K4M450-30FPF	450	230	1.1	1350	4500	158	F
K4M450-30APF	450	230	1.1	1350	4500	158	A
K4M500-30APF	500	420	2	1350	6100	170	A
K4M500-30FPF	500	420	2	1350	6100	170	F

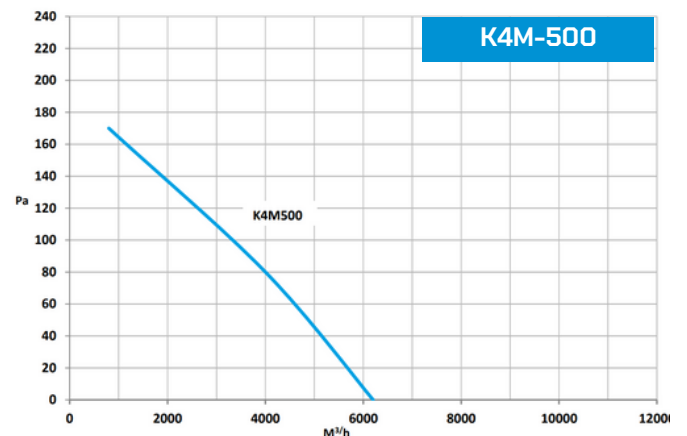
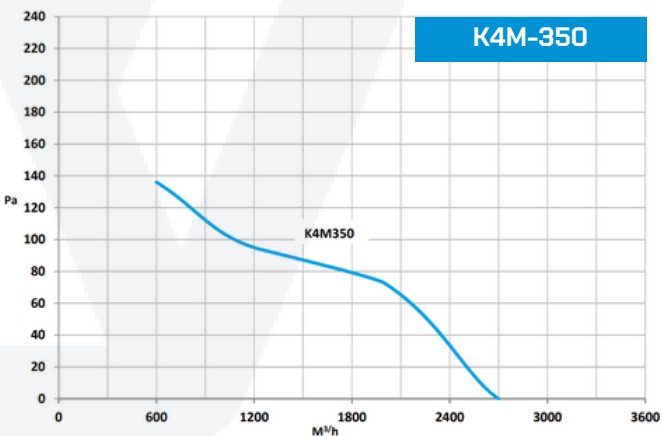
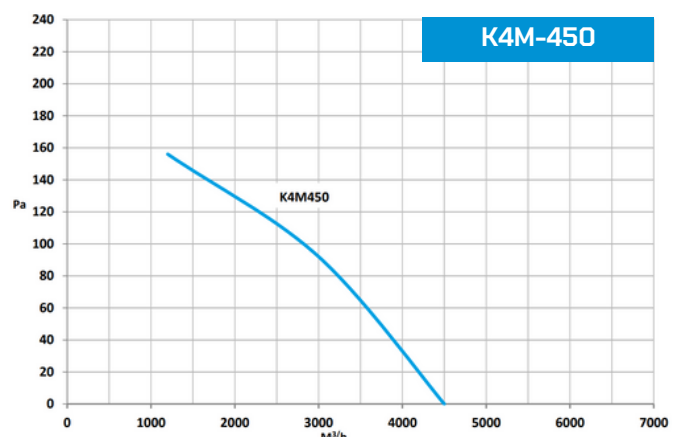
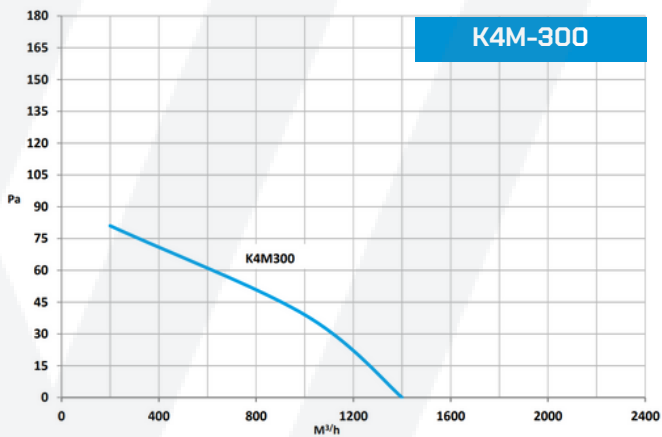
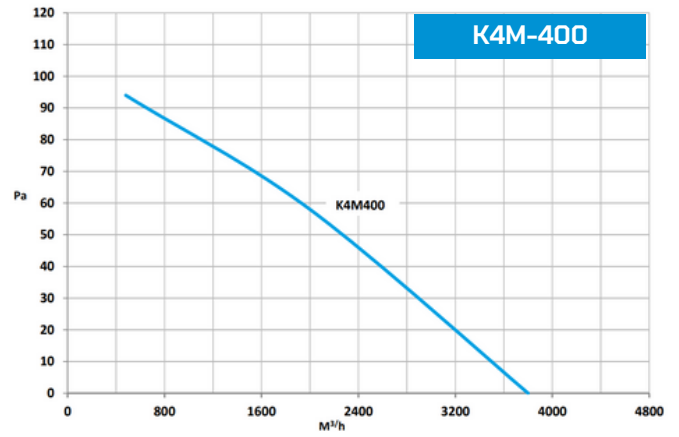
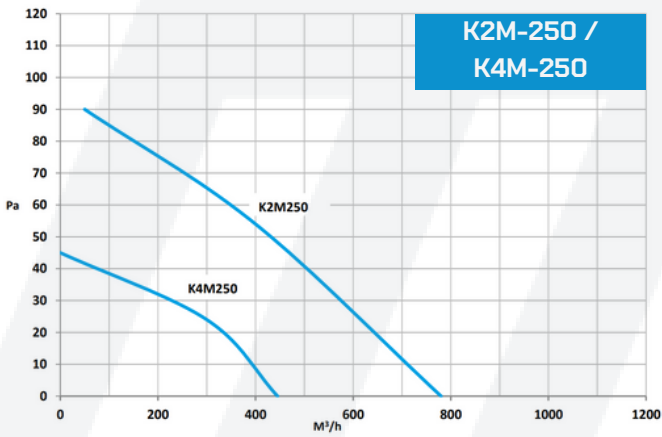



[sales@ventuer.co.nz](mailto:sales@ventuer.co.nz)



[www.ventuer.co.nz](http://www.ventuer.co.nz)

#### North Island

 +64 9 973 3616

 10 Morrison Drive, Warkworth, Auckland 0910

#### South Island

 +64 3 928 5937

 34 Onslow Street, Invercargill 9812