



Wavin SiTech+

for low-noise
soil & waste drainage



Wavin SiTech+

System description

Wavin SiTech+ is a mineral reinforced polypropylene (PP) soil and waste system. The system offers increased robustness, low-noise properties and improved ease of installation.

We have increased the weight of the fittings by 20% for improved acoustic comfort during water flow. Its flexible connectivity and push-fit system makes SiTech+ a complete plug and play solution for waste water discharge in buildings.

Quality of living is an important consideration in building design. A reduction of noise in water discharge systems improves end-experience in both living and working environments. Wavin SiTech+ meets the latest construction requirements and fulfills customers' demand for increased comfort and quality.

Key system benefits

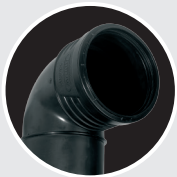

▶ **Less noise**

20% heavier fittings set a new market standards in this segment. SiTech+ is a high performance system that reduces the acoustics of water flow.



▶ **Easier to install**

Ribbed fittings provide enhanced grip for easy installation in complex environments. SiTech+ is perfect for any project, from small renovations to large-scale construction jobs.

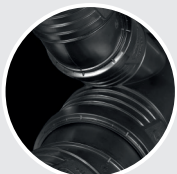

▶ **Angular rotation guidance**

Fittings have different markings at 15° and 45° intervals for easy alignment. SiTech+ makes it easy to align fittings which need to be positioned at a rotated angle.



▶ **Insertion depth check**

Ribs on the spigots of the fittings checks complete insertion into the socket. These easily visible SiTech+ markings can also confirm the exact 10 mm space needed to cope with thermal expansions at long pipe lengths.



▶ **New black color**

The new black color adds to the durability and robustness of SiTech+. The black color improves protection against UV radiation when stored outside at a building site. Furthermore the matte black finish is less sensitive to dirt and gives the system a professional appearance.

Application

Wavin SiTech+ meets all standards set for soil & waste discharge systems (EN 1451-1), including noise reduction and fire resistance (EN 13501-1). The emitted noise level of SiTech+ is measured by the Stuttgart Fraunhofer Physical Constructions Institute (DIN EN 14366).

Wavin SiTech+ is the ideal solution for installation in multi-storey building and those that are particularly sensitive to noise like apartment buildings, hotels, offices, hospitals, elderly homes and libraries.

Wavin SiTech+ can be used for water discharge at temperatures up to 90°C, with peaks of to 95°C for short periods. It can also be used at low temperatures up to -20°C. This durability makes it an ideal solution for extreme-temperature drainage areas such as kitchens, laundromats and industrial waste environments.

Please contact Wavin if you have any questions about particular application environments.

The system is offered in a full range of diameters:

- ⊕ 32 mm
- ⊕ 40 mm
- ⊕ 50 mm
- ⊕ 75 mm
- ⊕ 90 mm
- ⊕ 110 mm
- ⊕ 125 mm
- ⊕ 160 mm

Special fittings

The Wavin SiTech+ portfolio includes specialized fittings for easier and more efficient installation and use, particularly in areas where space is limited.

Shower branches provide an easy connection of both the toilet and shower to the down pipe.

Swept branches, as compared to sharp angle fittings, allow water to run more smoothly while reducing overall noise levels, improve the ventilation and increase the flow rate.

The new design of access pipes makes inspection easier.



WaterMark

AS/NZS 7671: 2010

WM 74576



Installation

Handling

- ⦿ Handle pipes and fittings with care. Excessive scratching or impact stress on the pipe may damage the external structure or affect the seal properties.
- ⦿ Loose pipes need to be unloaded by hand. When pipes are inserted one inside the other, always remove the inside pipe first.
- ⦿ When bundles of pipes are unloaded by fork truck, we recommend the wrap nylon sheaths around metal forks or use plastic forks. Metal forks, hooks and chains may not come in contact with the pipes. Do not use forks with an extension.
- ⦿ If the loading or unloading is carried out with a crane and excavator arms, the pipes must be raised in the central area with a sling of adequate width.

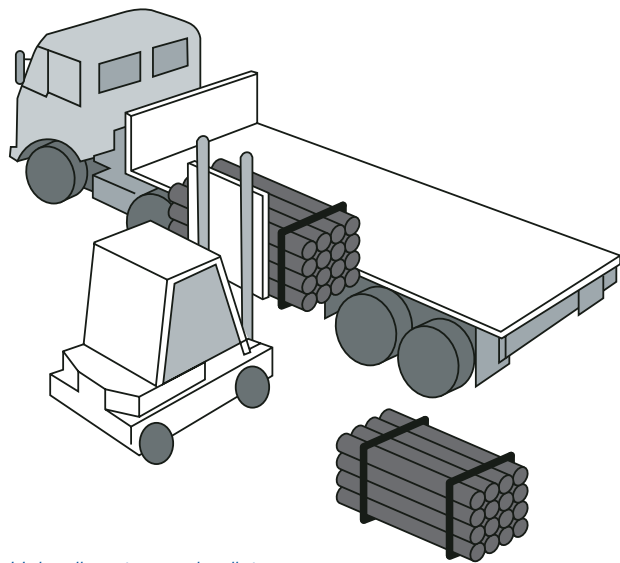

Unloading strapped pallets.

Transport

- ⦿ Wavin SiTech+ pipes, when no longer packed in original packaging, must be stored fully supported over their total length on a clean surface during transport.
- ⦿ Bending of the pipes should be avoided.
- ⦿ Impact stress on pipe and fittings must be prevented.

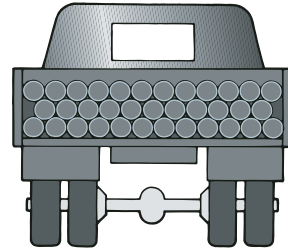

Transport of loose Wavin pipes.

Storage

- ⦿ Always store pipes on a flat surface.
- ⦿ Pallets must be stored at a maximum height of 1.5 m without additional supports or side barriers.
- ⦿ Loose pipes:
 - must have at least 2 side supports equally spread over the pipe length,
 - maximum height of storing loose pipes is 1.5 m.,
 - the ideal situation is to support the loose pipes along their whole length. If this is not possible, place wooden supports of at least 75 mm wide under the pipe at a distance of maximum 1 m.,
 - stack the different sizes of pipes separately or, if this is not possible, stack them with the largest diameters on the bottom,
 - socketed pipes should be stacked in an alternating order to secure support over the full pipe length (see picture).
- ⦿ Fittings are supplied in carton boxes and must be stored indoors. Deformation resulting from excessive loads on the fittings should always be avoided.
- ⦿ Store lubricant in a cool place, away from heat sources or direct sunlight.

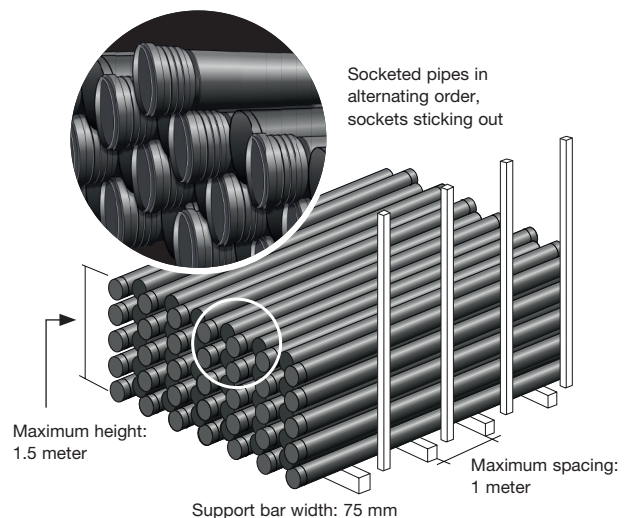

Cutting pipes

1. Cut the pipe cleanly at a right angles to its axis. Whenever possible, use a pipe cutter.

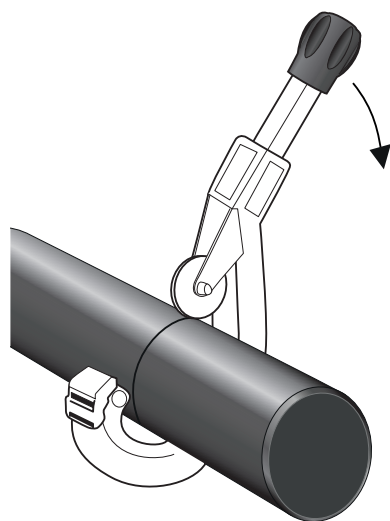

2. De-burr the cut end with a scraper.

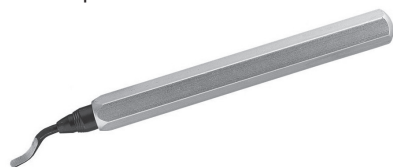

3. Chamfer the pipe end 5 mm over the length of the pipe, at 15°.

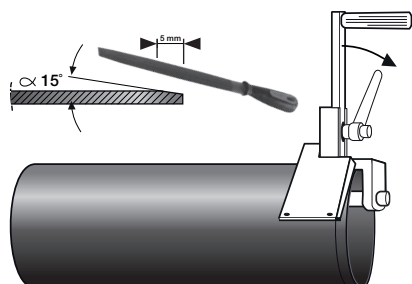

Ring seal / push-fit jointing

1. Ensure the pipe cut is chamfered.
2. Check that the sealing ring is properly seated in the seal groove of the fitting or pipe.
3. Ensure all components to be joined are dry, clean and free from dirt or dust. Ensure that there are no deep scratches on the pipe or fitting spigot as these may prevent the sealing ring from forming a watertight seal.
4. Lubricate evenly around the pipe or fitting spigot using Wavin lubricant. Do not use oils or greases.
5. Correctly align the components to be joined.
6. Push the pipe or fitting spigot fully into the socket. When inserting a pipe length of 2 metres or more, mark the pipe spigot at the socket face and then withdraw it by 10 mm to allow for thermal expansion.
7. Make a subsequent check to ensure that the expansion gap is not lost during further installation work.

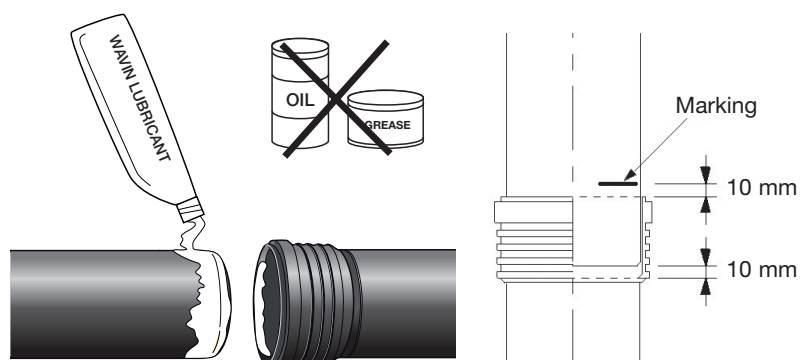

Installation

Pipe supports

- Use only rubber lined pipe clamps to minimise structure borne sound.
- Pipes should be supported at the following maximum distances:

OD [mm]	Maximum supporting distances	
	Vertical [m]	Horizontal [m]
32	1.50	0.50
40	1.50	0.60
50	1.50	0.75
75	2.00	1.10
90	2.00	1.35
110	2.00	1.65
125	2.00	1.85
160	2.00	2.40

- Ensure the pipe system is installed free of tension.
- Fixed-point brackets prevent pipe movement after the screws are tightened. After tightening the screws of a sliding bracket the pipe can still be moved through the bracket.
- For every pipe of length of 2 metre or more, place a fixed-point bracket directly next to the socket, as shown at point ①.
- For vertical pipes, the fixed-point bracket always needs to be installed at the top side of the pipe underneath the socket. Ensure that the expansion gap of 10 mm at the spigot end ② is not lost during placement of the fixed-point bracket.
- Next to each fitting, or groups of fittings, always a fixed-point bracket should be installed.
- Any additional pipe brackets, both for vertical as well as horizontal pipes, must be fitted as a sliding bracket ③ to allow for linear expansion due to changes in temperature.
- If there is an option to fix the bracket to different walls, always take the wall with the highest mass.
- Sections of piping with fittings or short pipes must be secured with pipe brackets at intervals short enough to ensure that they cannot slide apart.

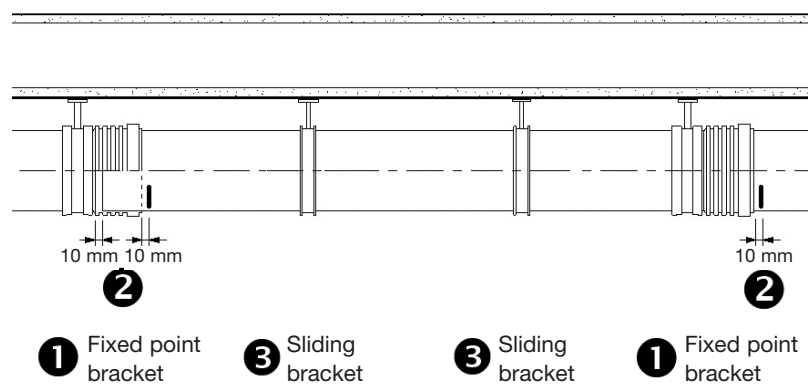
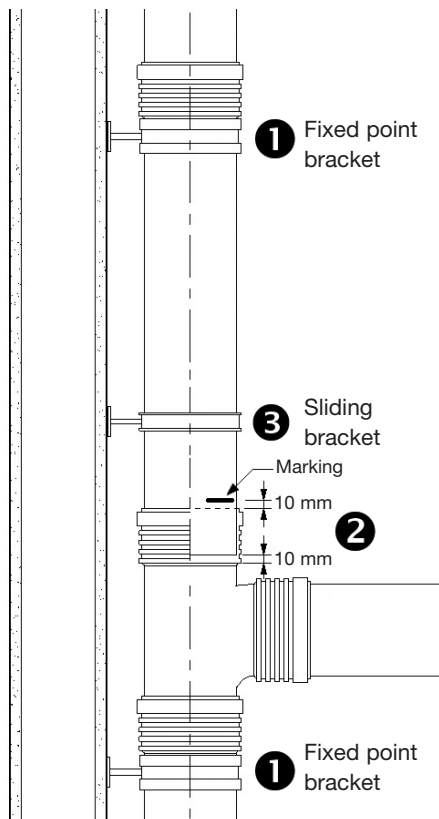

Pipe routing and special fittings

Vertical soil stack to horizontal

- Never use a 90° bend when connecting a vertical soil stack to a horizontal pipe, always use two 45° bends.
- In buildings with more than three storeys, (>10 metre soil stack) install a 250 mm pipe between the two 45° bends, when space allows. This 250 mm straight area in the bend will reduce the noise created by the water flowing from the soil stack to the horizontal collector pipe.
- Secure a proper fixation of this part by using two fixed point brackets ①, one fixed to a short piece of pipe fixing in the vertical plane and one fixed point bracket as close as possible to the socket of the first horizontal pipe.

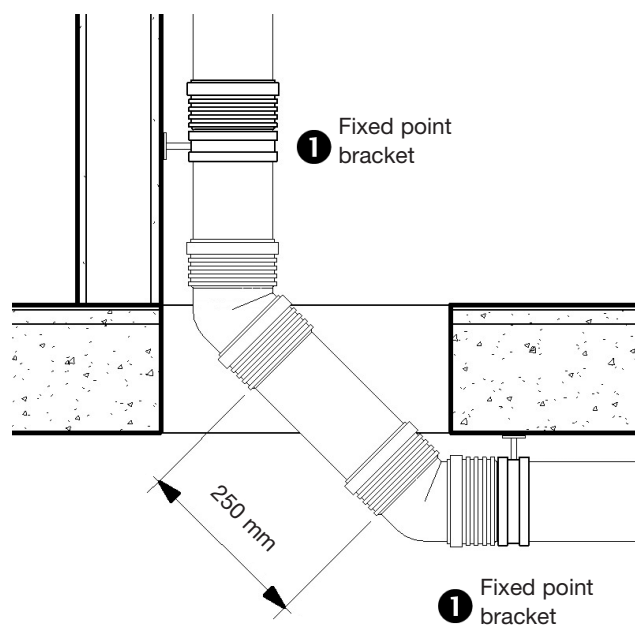

Floor and ceiling crossings

- Floor and ceiling crossings must be made both moisture resistant and soundproof using e.g. mineral wool or foam material.

Shower branch

- For an economic and easy installation of a toilet and waste pipes separately to the soil stack you can use a Shower branch ①.

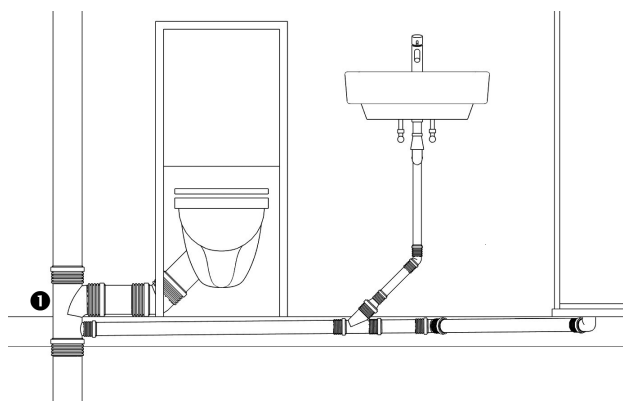

Fire collars

OC's to write own text depending on local range of fire collars and local fire regulations.

Installation

Repairs using HepSure rubber repair couplers

If a pipe section needs to be replaced or a Tee piece needs to be added to the pipe system, please follow the following procedure.

1. Cut out the part which needs to be replaced. When inserting a Tee piece at a later stage, please secure that the level of the branch is located at the right height.

The Z1 value is mentioned for each Tee piece in the product overview.

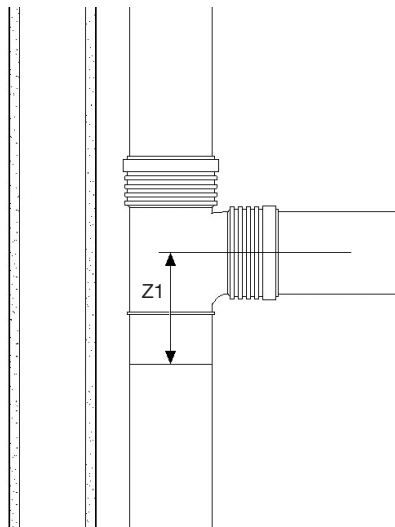

2. Slide the HepSure rubber repair coupler completely over the existing pipe.
3. Secure that the pipe (or pipe and Tee piece) has the same length as the part which has been cut out.
4. Measure half of the repair coupler length (60 mm). Measure the same length (60 mm) from the new pipe ends and mark the pipe.

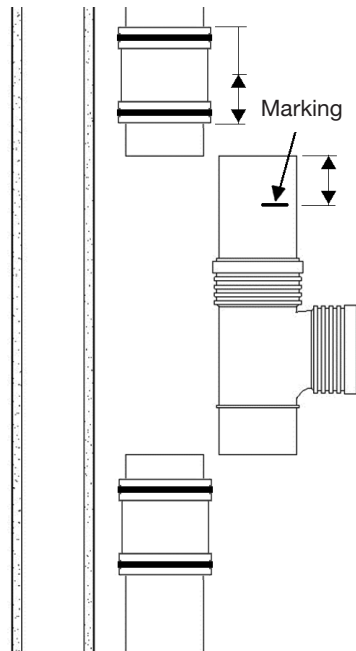

5. Insert the new pipe (pipe with Tee piece) and slide the HepSure repair couplers to the marked positions.

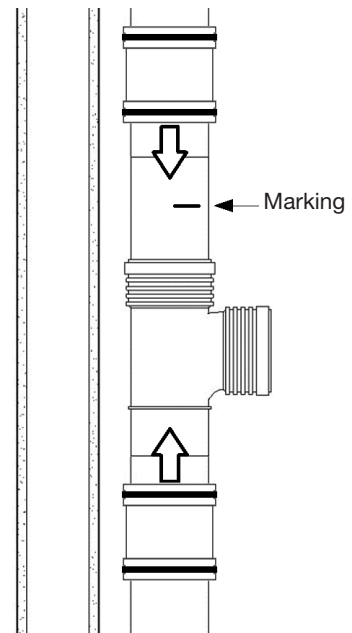

6. Tighten the screws to ensure a water tight connecting and no movement.

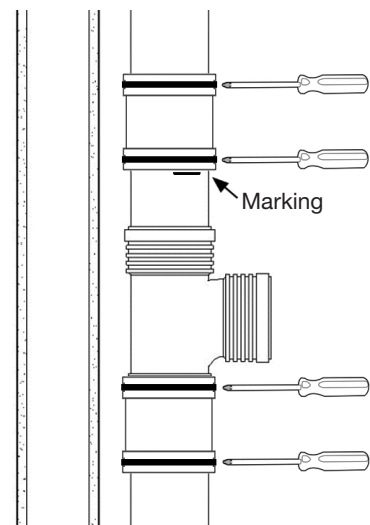

Repairs using repair couplers

If a pipe section needs to be replaced or a Tee piece needs to be added to the pipe system, please follow the following procedure.

1. Cut out the part which needs to be replaced. When inserting a Tee piece at a later stage, please secure that the level of the branch is located at the right height. The Z1 value is mentioned for each Tee piece in the product overview.

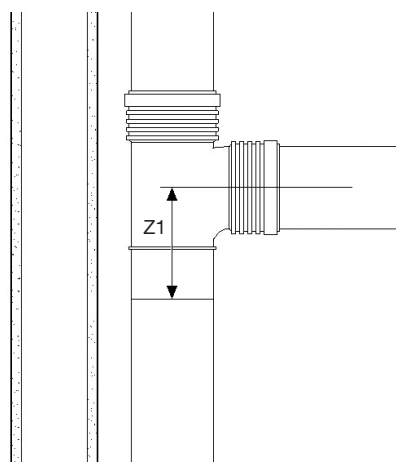

2. Install a short piece of temporary pipe halfway onto the repair coupler to secure a correct positioning of the rubber seal.

3. Install the free half of the coupler onto the existing pipe and slide the repair coupler completely over the existing pipe.

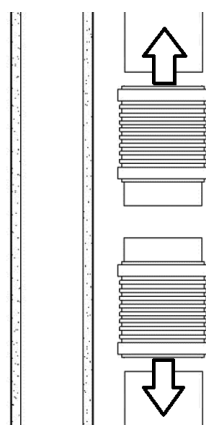

4. Secure that the pipe (or pipe and Tee piece) has the same length as the part which has been cut out.

5. Measure half of the repair coupler length. Measure the same length from the new pipe ends and mark the pipe.

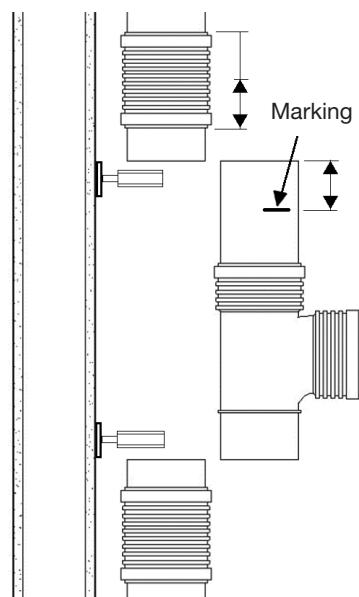

6. Install as close as possible to the two pipe ends wall plates for the fixed-point brackets and mount the threaded rod and back part of the brackets. When fixing the repair couplers with tensile resistant clamps this step can be skipped.

7. Install a tensile resistant clamp on each repair coupler to ensure no movement.

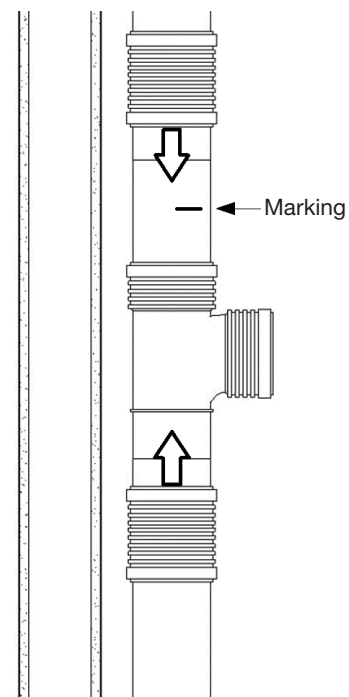

Installation

Repairs using a long socket and repair coupler

- Finalise the installation of the fixed-point brackets or install a tensile resistant clamp on each repair coupler to ensure no movement.

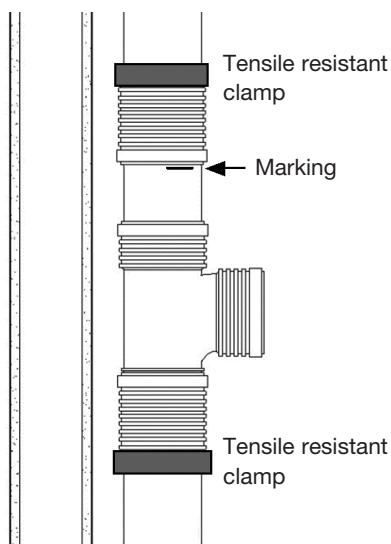
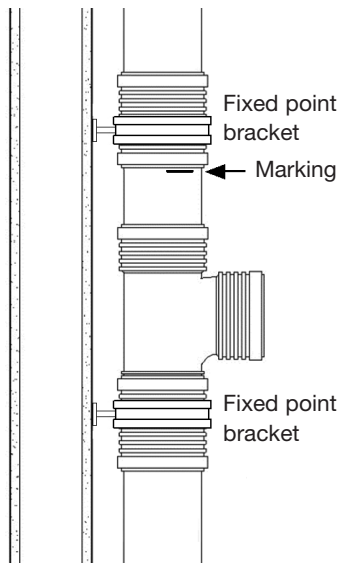

- When inserting a Tee piece at a later stage, please secure that the level of the branch is located at the right height. The Z1 value is mentioned for each Tee piece in the product overview.

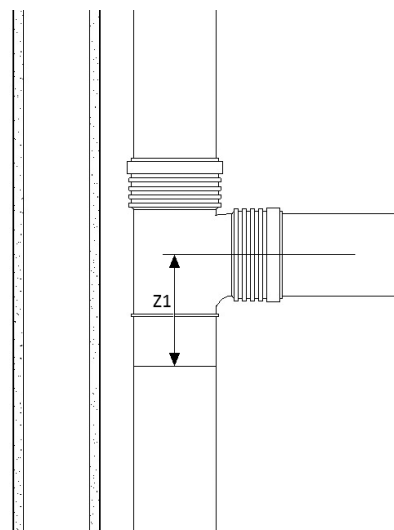

- When inserting a Tee piece, the length of the part to be cut out should have the length of the Tee piece (L) + 20 mm + the length of the spigot of the long socket (Q).

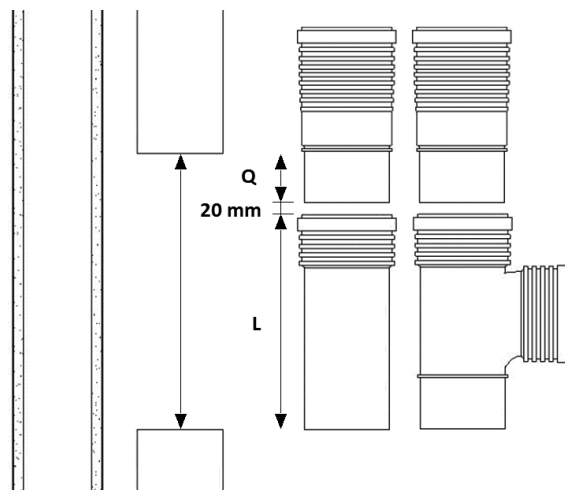

When replacing a piece of pipe, secure that the total length of the new socketed pipe (L) equals the length of the part cut out minus the length of the spigot of the Tee piece (Q) minus 20 mm.

- Install close to the two pipe ends wall plates for the fixed-point brackets and mount the threaded rod and back part of the brackets. When fixating the repair couplers with tensile resistant clamps this step can be skipped.

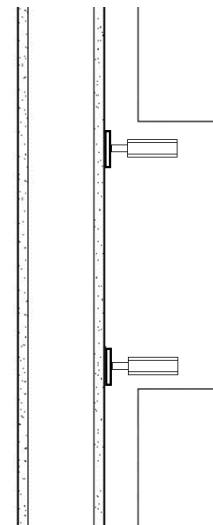

4. Install a short piece of temporary pipe halfway onto the repair coupler to secure a correct positioning of the rubber seal.
5. Install the free half of the coupler onto the existing pipe and slide the repair coupler completely over the existing pipe.

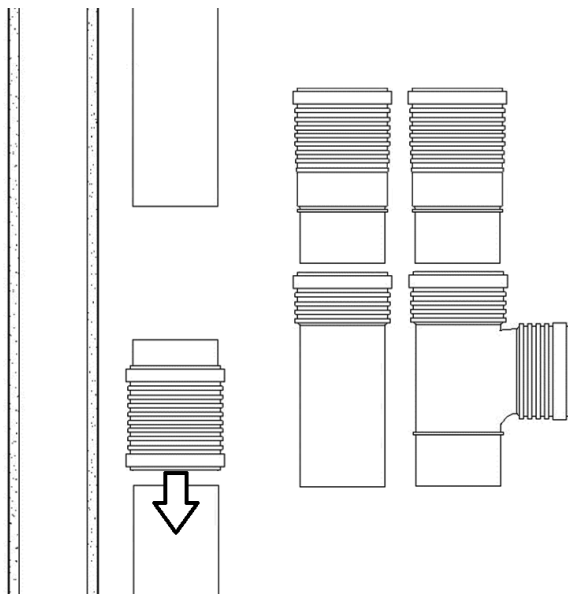

6. Slide the long socket over the other pipe end.

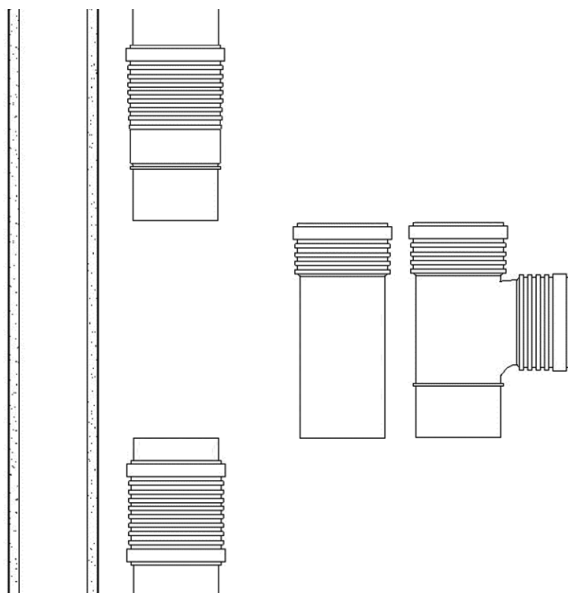

7. Push the socketed end of the Tee piece or pipe on to the long socket.

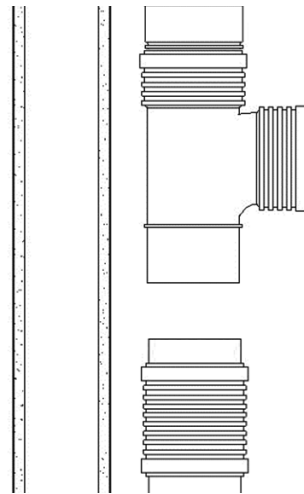

8. Push the long socket with the Tee piece or pipe till the two pipe ends meet.
9. Finalise the installation of the fixed-point brackets or install a tensile resistant clamp on the long socket to ensure no movement.
10. If a pipe is inserted, measure half of the repair coupler length. Measure the same length from the new pipe end and mark the pipe.

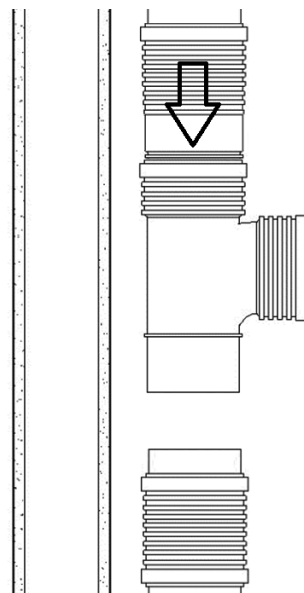

Installation

11. Slide the repair coupler over the spigot end of the Tee piece or to the marking on the pipe.

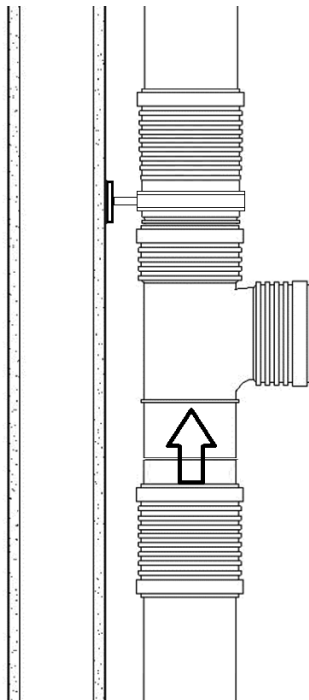

12. Finalise the installation of the fixed-point bracket or install a tensile resistant clamp on the repair socket to ensure no movement.

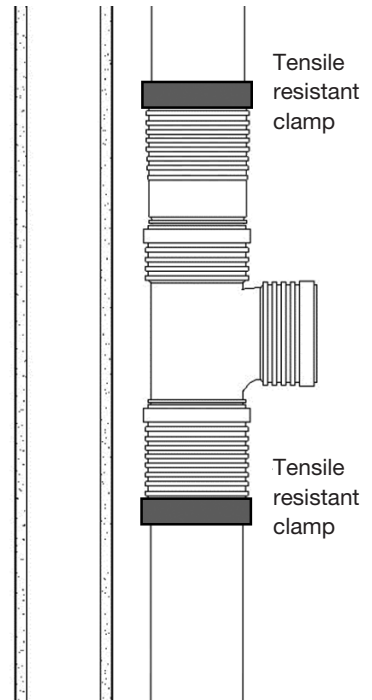
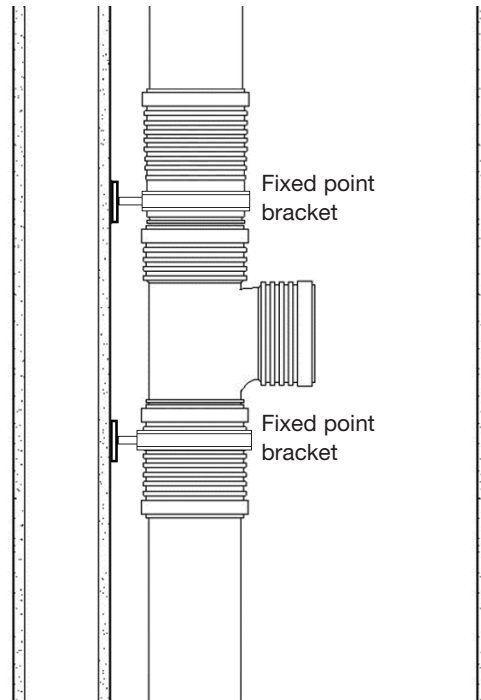

Technical data

Wavin SiTech+

Wavin SiTech+ is an innovative soil and waste system with proven low noise technology.

Technical features:

- ⦿ Optimized 3-layer pipe structure for reduced noise levels
- ⦿ Mineral reinforced polypropylene (PP) material for high durability and heat-resistance
- ⦿ Socketed connections and prefabricated elastomer gaskets (SBR) for fast, easy and secure installation

Diameter Do1=Ds2	Wall thickness s	Socket length P	Class Serie
32 mm	2.0 mm	43 mm	S16
40 mm	2.0 mm	45 mm	S16
50 mm	2.1 mm	47 mm	S16
75 mm	2.6 mm	53 mm	S14
90 mm	3.1 mm	57 mm	S14
110 mm	3.6 mm	64 mm	S16
125 mm	4.0 mm	71 mm	S16
160 mm	5.0 mm	76 mm	S16

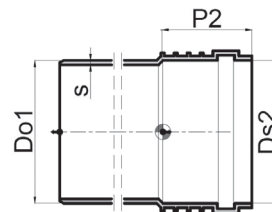

Characteristics	Reference Value	Norm
Internal tensions (150° C x 60')	≤ 2.0%	ISO 2505
Impact resistance (-20° C)	TIR ≤ 10%	EN 744
Fire behavior	B2	DIN 4102-1
	E	DIN 13501-1
Density	Pipe 1.30 gr/cm ³	UNI EN ISO
	Fittings 1.50 gr/cm ³	1183-1
OIT	≥ 10 min	EN 728
Operating temperature	90°C water discharge	
	95°C shortterm peak load	
Expansion linear	0.12 mm/m/K	ASTM D 696
Effects of heat (150° C x 60')	No delamination/ deformation	EN ISO 580
Water leakage	No leakage	EN 1053
Tightness	No leakage	EN 1054
Thermal cycle	No leakage	EN 1055
Ring stiffness	≥ 6 Kn/m ²	

Acoustic level according to EN 14366 at 2 l/s measured at Fraunhofer institute	Air borne sound	Structure borne sound
Bismat 1000 brackets (report no. P-BA 24/2016)	52 dB(A)	12 dB(A)
Mupro Optimal green brackets (report no. P-BA 25/2016)	52 dB(A)	20 dB(A)

Product range





CONNECT TO BETTER

Wavin SiTech+ Product range

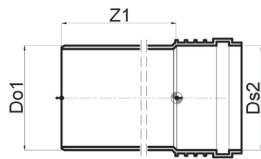

Pipe Single Socket

EAN Code	SAP Code	Dimensions mm, m	Do1=Ds2 mm	Z1 mm
8018464194663	3067456	32, L=0.25	32	250
8018464194670	3067457	32, L=0.5	32	500
8018464194687	3067458	32, L=1	32	1000
8018464194694	3067629	32, L=1.5	32	1500
8018464194700	3067630	32, L=2	32	2000
8018464194717	3067631	40, L=0.25	40	250
8018464194724	3067632	40, L=0.5	40	500
8018464194731	3067633	40, L=1	40	1000
8018464194748	3067634	40, L=1.5	40	1500
8018464194755	3067635	40, L=2	40	2000
8018464004269	3071125	50, L=0.15	50	150
8018464194762	3067636	50, L=0.25	50	250
8018464194779	3067637	50, L=0.5	50	500
8018464194786	3067638	50, L=1	50	1000
8018464194793	3067639	50, L=1.5	50	1500
8018464194809	3067640	50, L=2	50	2000
8018464194816	3067641	50, L=3	50	3000
8018464194823	3067642	75, L=0.15	75	150
8018464194830	3067643	75, L=0.25	75	250
8018464194847	3067644	75, L=0.5	75	500
8018464194854	3067645	75, L=1	75	1000
8018464194861	3067646	75, L=1.5	75	1500
8018464194878	3067647	75, L=2	75	2000
8018464194885	3067648	75, L=3	75	3000
8018464194892	3067649	90, L=0.15	90	150
8018464194908	3067650	90, L=0.25	90	250
8018464194915	3067651	90, L=0.5	90	500
8018464194922	3067652	90, L=1	90	1000
8018464194939	3067653	90, L=1.5	90	1500
8018464194946	3067654	90, L=2	90	2000
8018464194953	3067655	90, L=3	90	3000
8018464194960	3067656	110, L=0.15	110	150
8018464194977	3067657	110, L=0.25	110	250
8018464194984	3067658	110, L=0.5	110	500
8018464194991	3067659	110, L=1	110	1000
8018464195004	3067660	110, L=1.5	110	1500
8018464195011	3067661	110, L=2	110	2000
8018464195028	3067662	110, L=3	110	3000

Wavin SiTech+ Product range

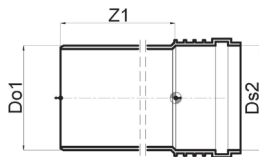

Pipe Single Socket (continued)

EAN Code	SAP Code	Dimensions mm, m	Do1=Ds2 mm	Z1 mm
8018464195035	3067663	125, L=0.25	125	250
8018464195042	3067664	125, L=0.5	125	500
8018464195059	3067665	125, L=1	125	1000
8018464195066	3067666	125, L=1.5	125	1500
8018464195073	3067667	125, L=2	125	2000
8018464195080	3067668	125, L=3	125	3000
8018464195097	3067669	160, L=0.25	160	250
8018464195103	3067670	160, L=0.5	160	500
8018464195110	3067671	160, L=1	160	1000
8018464195134	3067673	160, L=2	160	2000
8018464195141	3067674	160, L=3	160	3000

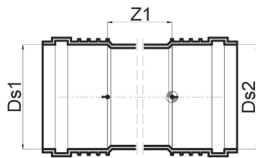
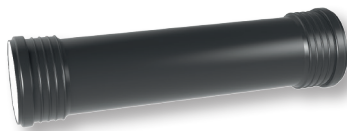

Pipe Double Socket

EAN Code	SAP Code	Dimensions mm, m	Ds1=Ds2 mm	Z1 mm
8018464195158	3067675	32, L=0.5	32	500
8018464195165	3067676	32, L=1	32	1000
8018464195172	3067677	32, L=2	32	2000
8018464195189	3067678	32, L=3	32	3000
8018464195196	3067679	40, L=0.5	40	500
8018464195202	3067680	40, L=1	40	1000
8018464195219	3067681	40, L=1.5	40	1500
8018464195226	3067682	40, L=2	40	2000
8018464195233	3067683	40, L=3	40	3000
8018464195240	3067684	50, L=0.5	50	500
8018464195257	3067685	50, L=1	50	1000
8018464195264	3067686	50, L=1.5	50	1500
8018464195271	3067687	50, L=2	50	2000
8018464195288	3067688	50, L=3	50	3000
8018464195295	3067689	75, L=0.5	75	500
8018464195301	3067690	75, L=1	75	1000
8018464195318	3067691	75, L=1.5	75	1500
8018464195325	3067692	75, L=2	75	2000
8018464195332	3067693	75, L=3	75	3000

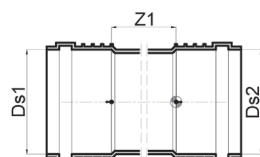
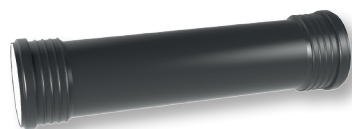

Pipe Double Socket (continued)

EAN Code	SAP Code	Dimensions mm, m	Ds1=Ds2 mm	Z1 mm
8018464195349	3067694	90, L=0.5	90	500
8018464195356	3067695	90, L=1	90	1000
8018464195363	3067696	90, L=1.5	90	1500
8018464195370	3067697	90, L=2	90	2000
8018464195387	3067698	90, L=3	90	3000
8018464195394	3067699	110, L=0.5	110	500
8018464195400	3067700	110, L=1	110	1000
8018464195417	3067701	110, L=1.5	110	1500
8018464195424	3067702	110, L=2	110	2000
8018464195431	3067703	110, L=3	110	3000
8018464195448	3067704	125, L=0.5	125	500
8018464195455	3067705	125, L=1.0	125	1000
8018464195462	3067706	125, L=1.5	125	1500
8018464195479	3067707	125, L=2	125	2000

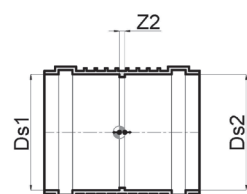

Coupler

EAN Code	SAP Code	Dimensions mm	Ds1=Ds2 mm	Z2 mm
8018464196377	3067797	32	32	1
8018464196384	3067798	40	40	1
8018464196391	3067799	50	50	1
8018464196407	3067800	75	75	2
8018464196414	3067801	90	90	2
8018464196421	3067802	110	110	2
8018464196438	3067803	125	125	3
8018464196445	3067804	160	160	4

Wavin SiTech+ Product range

Long Eccentric Reducer

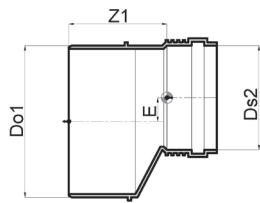

EAN Code	SAP Code	Dimensions mm	Do1 mm	Ds2 mm	Z1 mm	E mm
8018464196520	3067812	40-32	40	32	60	3
8018464196537	3067813	50-32	50	32	66	9
8018464196544	3067814	50-40	50	40	63	5
8018464196551	3067815	75-50	75	50	77	12
8018464196568	3067816	110-50	110	50	106	27
8018464196575	3067817	110-75	110	75	98	17
8018464196582	3067818	125-110	125	110	98	7
8018464196599	3067819	160-110	160	110	121	24
8018464196605	3067820	160-125	160	125	117	16

Short Eccentric Reducer

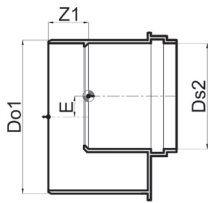

EAN Code	SAP Code	Dimensions mm	Do1 mm	Ds2 mm	Z1 mm	E mm
8018464196612	3067821	90-50	90	50	27	17
8018464196629	3067822	90-75	90	75	22	4
8018464196636	3067823	110-90	110	90	26	6

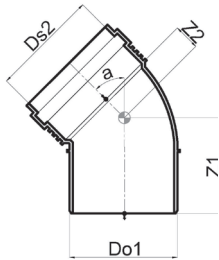

Bend

EAN Code	SAP Code	Dimensions mm	Do1=Ds2 mm	Z1 mm	Z2 mm	a °
8018464195486	3067708	32 x 15°	32	49	8	15
8018464195561	3067716	32 x 30°	32	51	10	30
8018464195646	3067724	32 x 45°	32	54	13	45
8018464195721	3067732	32 x 67.5°	32	58	17	67.5
8018464195790	3067739	32 x 87.5°	32	62	21	87.5
8018464195493	3067709	40 x 15°	40	52	8	15
8018464195578	3067717	40 x 30°	40	55	11	30
8018464195653	3067725	40 x 45°	40	56	15	45
8018464195738	3067733	40 x 67.5°	40	63	20	67.5
8018464195806	3067740	40 x 87.5°	40	68	26	87.5
8018464195509	3067710	50 x 15°	50	55	9	15
8018464195585	3067718	50 x 30°	50	58	13	30
8018464195660	3067726	50 x 45°	50	65	17	45
8018464195745	3067734	50 x 67.5°	50	70	21	67.5
8018464195813	3067741	50 x 87.5°	50	78	31	87.5
8018464195516	3067711	75 x 15°	75	63	13	15
8018464195592	3067719	75 x 30°	75	68	18	30
8018464195677	3067727	75 x 45°	75	75	22	45
8018464195752	3067735	75 x 67.5°	75	84	34	67.5
8018464195820	3067742	75 x 87.5°	75	95	45	87.5
8018464195523	3067712	90 x 15°	90	69	15	15
8018464195608	3067720	90 x 30°	90	76	22	30
8018464195684	3067728	90 x 45°	90	85	26	45
8018464195769	3067736	90 x 67.5°	90	95	41	67.5
8018464195837	3067743	90 x 87.5°	90	108	54	87.5
8018464195530	3067713	110 x 15°	110	79	16	15
8018464195615	3067721	110 x 30°	110	88	24	30
8018464195691	3067729	110 x 45°	110	96	33	45
8018464195776	3067737	110 x 67.5°	110	108	47	67.5
8018464195844	3067744	110 x 87.5°	110	128	64	87.5
8018464195547	3067714	125 x 15°	125	88	20	15
8018464195622	3067722	125 x 30°	125	96	29	30
8018464195707	3067730	125 x 45°	125	105	38	45
8018464195783	3067738	125 x 67.5°	125	123	55	67.5
8018464195851	3067745	125 x 87.5°	125	141	74	87.5

Wavin SiTech+ Product range



Bend (continued)

EAN Code	SAP Code	Dimensions mm	Do1=Ds2 mm	Z1 mm	Z2 mm	a °
8018464195554	3067715	160 x 15°	160	97	25	15
8018464195639	3067723	160 x 30°	160	109	36	30
8018464195714	3067731	160 x 45°	160	121	48	45
8018464195868	3067746	160 x 87.5°	160	166	94	87.5



Branch

EAN Code	SAP Code	Dimensions mm	Do1=Ds3 mm	Ds2 mm	Z1 mm	Z2 mm	Z3 mm	a °
8018464195875	3067747	32-32 x 45°	32	32	54	42	42	45
8018464195882	3067748	40-32 x 45°	40	32	58	81	52	45
8018464195899	3067749	40-40 x 45°	40	40	58	52	52	45
8018464196124	3067772	40-40 x 87.5°	40	40	69	28	28	87.5
8018464195905	3067750	50-40 x 45°	50	40	55	59	57	45
8018464196131	3067773	50-40 x 87.5°	50	40	71	33	28	87.5
8018464195912	3067751	50-50 x 45°	50	50	64	71	71	45
8018464196063	3067766	50-50 x 67.5°	50	50	69	40	40	67.5
8018464196148	3067774	50-50 x 87.5°	50	50	82	35	36	87.5
8018464195929	3067752	75-50 x 45°	75	50	56	82	77	45
8018464196070	3067767	75-50 x 67.5°	75	50	70	55	46	67.5
8018464196155	3067775	75-50 x 87.5°	75	50	82	45	35	87.5
8018464195936	3067753	75-75 x 45°	75	75	74	96	96	45
8018464196162	3067776	75-75 x 87.5°	75	75	95	49	49	87.5
8018464195943	3067754	90-50 x 45°	90	50	56	106	96	45
8018464196179	3067777	90-50 x 87.5°	90	50	87	53	36	87.5
8018464195950	3067755	90-75 x 45°	90	75	77	141	121	45
8018464195967	3067756	90-90 x 45°	90	90	83	115	115	45
8018464196087	3067768	90-90 x 67.5°	90	90	94	70	70	67.5

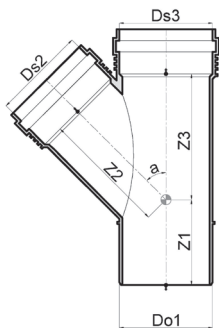

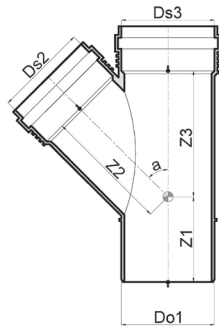

Branch (continued)

EAN Code	SAP Code	Dimensions mm	Do1=Ds3 mm	Ds2 mm	Z1 mm	Z2 mm	Z3 mm	a °
8018464195974	3067757	110 -50 x 45°	110	50	63	105	93	45
8018464196094	3067769	110-50 x 67.5°	110	50	77	76	54	67.5
8018464196186	3067778	110-50 x 87.5°	110	50	96	63	37	87.5
8018464195981	3067758	110-75 x 45°	110	75	71	122	113	45
8018464196100	3067770	110-75 x 67.5°	110	75	101	147	96	67.5
8018464196193	3067779	110-75 x 87.5°	110	75	109	66	52	87.5
8018464195998	3067759	110-90 x 45°	110	90	82	129	124	45
8018464196001	3067760	110-110 x 45°	110	110	108	138	138	45
8018464196117	3067771	110-110 x 67.5°	110	110	110	87	87	67.5
8018464196018	3067761	125-75 x 45°	125	75	70	133	121	45
8018464196025	3067762	125-110 x 45°	125	110	95	149	146	45
8018464196209	3067780	125-110 x 87.5°	125	110	133	77	71	87.5
8018464196032	3067763	125-125 x 45°	125	125	106	156	156	45
8018464196216	3067781	125-125 x 87.5°	125	125	141	80	79	87.5
8018464196049	3067764	160-110 x 45°	160	110	82	175	164	45
8018464196223	3067782	160-110 x 87.5°	160	110	165	103	103	87.5
8018464196056	3067765	160-160 x 45°	160	160	120	200	200	45
8018464196230	3067783	160-160 x 87.5°	160	160	165	111	101	87.5

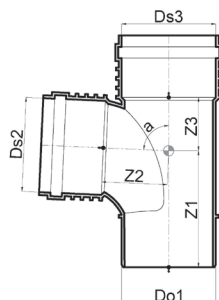

Swept Branch

EAN Code	SAP Code	Dimensions mm	Do1=Ds3 mm	Ds2 mm	Z1 mm	Z2 mm	Z3 mm	a °
8018464196735	3067833	90-90 x 87.5°	90	90	126	74	52	87.5
8018464196742	3067834	110-90 x 87.5°	110	90	137	86	53	87.5
8018464196759	3067835	110-110 x 87.5°	110	110	144	79	64	87.5

Wavin SiTech+ Product range

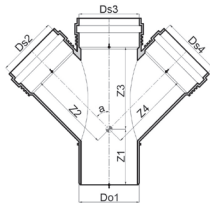

Double Branch

EAN Code	SAP Code	Dimensions mm	Do1=Ds3 mm	Ds2=Ds4 mm	Z1 mm	Z2=Z4 mm	Z3 mm	a °
8018464196728	3067832	75-50-50 x 87.5°	75	50	80	45	35	87.5
8018464196766	3067836	90-50-50 x 45°	90	50	56	106	96	45
8018464196773	3067837	110-50-50 x 45°	110	50	96	63	37	45

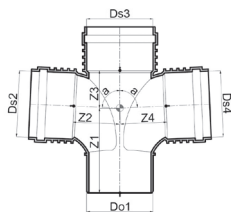

Double Swept Branch

EAN Code	SAP Code	Dimensions mm	Do1=Ds3 mm	Ds2=Ds4 mm	Z1 mm	Z2=Z4 mm	Z3 mm	a °
8018464196780	3067838	110-110-110 x 87.5°	110	110	144	79	64	87.5

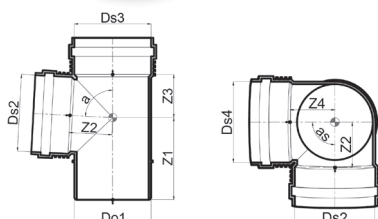

Corner Branch

EAN Code	SAP Code	Dimensions mm	Do1=Ds3 mm	Ds2=Ds4 mm	Z1 mm	Z2=Z4 mm	Z3 mm	a °	as °
8018464196711	3067831	110-50-50 x 87.5°	110	50	96	63	37	87.5	90



Shower Branch

EAN Code	SAP Code	Dimensions mm	Do1=Ds3 =Ds4 mm	Ds2 mm	Z mm	Z1 mm	Z2 mm	Z3 mm	Z4 mm	a °
8018464202054	3071186	90-90-50 x 87.5°	90	50	91	96	53	74	52	87.5
8018464202061	3071187	110-110-50 x 87.5°	110	50	111	96	63	79	64	87.5

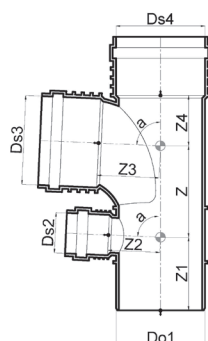

Access piece

EAN Code	SAP Code	Dimensions mm	Do1 mm	Z1 mm	Ds2 mm	Z2 mm	H mm	K mm	a °
8018464196247	3067784	50	50	83	50	36	80	65	90
8018464196254	3067785	75	75	102	75	50	111	93	90
8018464196261	3067786	90	90	118	90	60	132	110	90
8018464196278	3067787	110	110	135	110	72	155	131	90
8018464196285	3067788	125	125	142	125	74	162	131	90
8018464196292	3067789	160	160	200	160	121	236	141	90

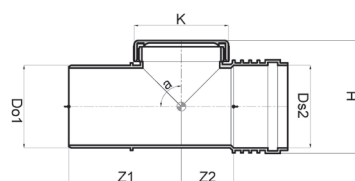

Wavin SiTech+ Product range

End Cap

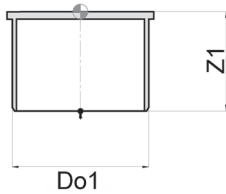

EAN Code	SAP Code	Dimensions mm	Do1 mm	Z1 mm
8018464196643	3067824	40	40	32
8018464196650	3067825	50	50	36
8018464196667	3067826	75	75	35
8018464196674	3067827	90	90	37
8018464196681	3067828	110	110	39
8018464196698	3067829	125	125	49
8018464196704	3067830	160	160	55

Repair Coupler

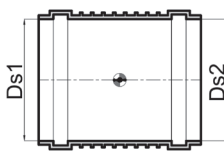

EAN Code	SAP Code	Dimensions mm	Ds1=Ds2 mm
8018464196308	3067790	40	40
8018464196315	3067791	50	50
8018464196322	3067792	75	75
8018464196339	3067793	90	90
8018464196346	3067794	110	110
8018464196353	3067795	125	125
8018464196360	3067796	160	160

* Use a repair coupler always in combination with a tensile resistant clamp or a fixed-point bracket on the coupler or one at each side of the couplers to secure no movement.

Tensile resistant clamp



EAN Code	SAP Code	Dimensions mm
4026294790874	4048918	32
4026294790850	4048917	40
4026294656187	4035782	50
4026294656194	4035794	75
4026294656231	4035808	90
4026294656248	4035810	110
4026294656200	4035795	125
4026294656262	4035811	160

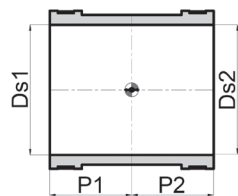

HepSure rubber repair coupler

EAN Code	SAP Code	Do pipe mm	Ds min mm	Ds max mm	P1=P2 mm
5027888225368	4037327	50	50	65	60
5027888278340	4041120	75	75	90	60
5027888225375	4037329	90	80	90	60
5027888140036	4039413	110	100	115	60
5027888140012	4039435	125	120	135	60
5027888186607	4038815	160	120	150	60

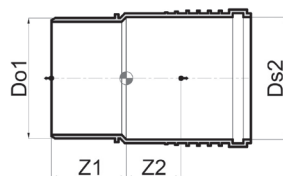

Expansion socket | Long socket

EAN Code	SAP Code	Dimensions mm	Do1=Ds2 mm	Z1 mm	Z2 mm
8018464196452	3067805	40	40	50	53
8018464196469	3067806	50	50	52	56
8018464196476	3067807	75	75	59	64
8018464196483	3067808	90	90	63	70
8018464196490	3067809	110	110	152	79
8018464196506	3067810	125	125	171	91
8018464196513	3067811	160	160	187	99

* Use a long socket always in combination with a fixed point bracket on the socket to secure no movement. When a long socket is used for a repair and no thermal expansion is compensated in the socket, a tensile resistant clamp can be used to secure no movement.

Wavin SiTech+ Product range

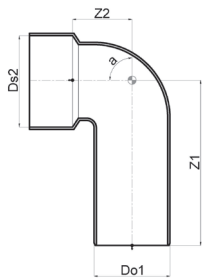

Trap Bend

EAN Code	SAP Code	Dimensions mm	Do1 mm	Ds2* mm	Z1 mm	Z2 mm	a °
8018464196810	3067841	32	32	46	70	24	90
8018464196827	3067842	40	40	46	79	30	90
8018464196797	3067839	long 40	40	46	125	30	90
8018464196803	3067840	50	50	53	79	35	90

* Add separate rubber transition reducer

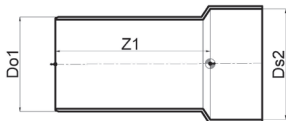

Trap Connector

EAN Code	SAP Code	Dimensions mm	Do1 mm	Ds2* mm	Z1 mm
8018464196834	3067843	32	32	46	52
8018464196841	3067844	40	40	46	54
8018464196858	3067845	50	50	53	55

* Add separate rubber transition reducer

Transition Reducer Rubber

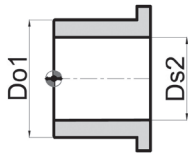

EAN Code	SAP Code	Dimensions mm / inches	Do1 mm	Ds2 inches
8018464004481	4026398	46 - 1"	46	1"
8018464004498	4026399	46 - 1¼"	46	1¼"
8018464004504	4009859	46 - 1"/1¼"	46	1"/1¼"
8018464004511	4009860	46 - 1½"	46	1½"
8018464004528	4024657	53 - 1"/1¼"	53	1"/1¼"
8018464004535	4024658	53 - 1½"	53	1½"

Floor Gully



- Water seal approx. 71 mm
- Material: PP-MD
- Colour: Black

Code	Qty/Box
3086119	2

3x DN 50 inlets (factory closed) + 1 x DN75 outlet. Includes removable baffle. DN50 inlets require DN50 double socket.

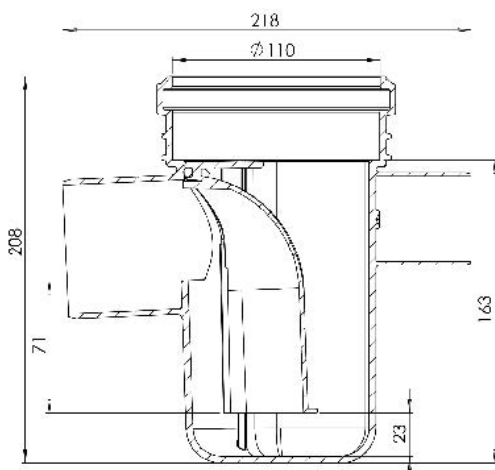

Baffle (spare part)



Code	Qty/Box
3086121	1

Removable baffle for floor gully with rubber sealing to provide airtightness

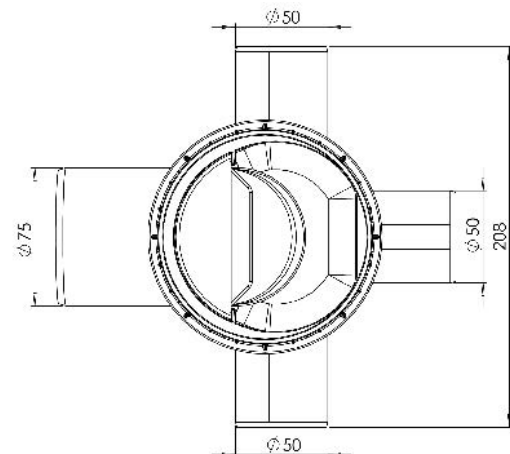

Distributed by:

0800 246 810

1800 666 952

LEAP AUSTRALASIA LTD
61 Port Road
Seaview
Lower Hutt
New Zealand

LEAP AUSTRALASIA PTY LTD
95b Cheltenham Road
Dandenong
Victoria 3175
Australia



CONNECT TO BETTER

Wavin operates a programme of continuous product development, and therefore reserves the right to modify or amend the specification of their products without notice. All information in this publication is given in good faith, and believed to be correct at the time of going to press. However, no responsibility can be accepted for any errors, omissions or incorrect assumptions.

© 2016 Wavin
Wavin reserves the right to make alterations without prior notice. Due to continuous product development, changes in technical specifications may change. Installation must comply with the installation instructions.