

SFA

129

01.18
INDO

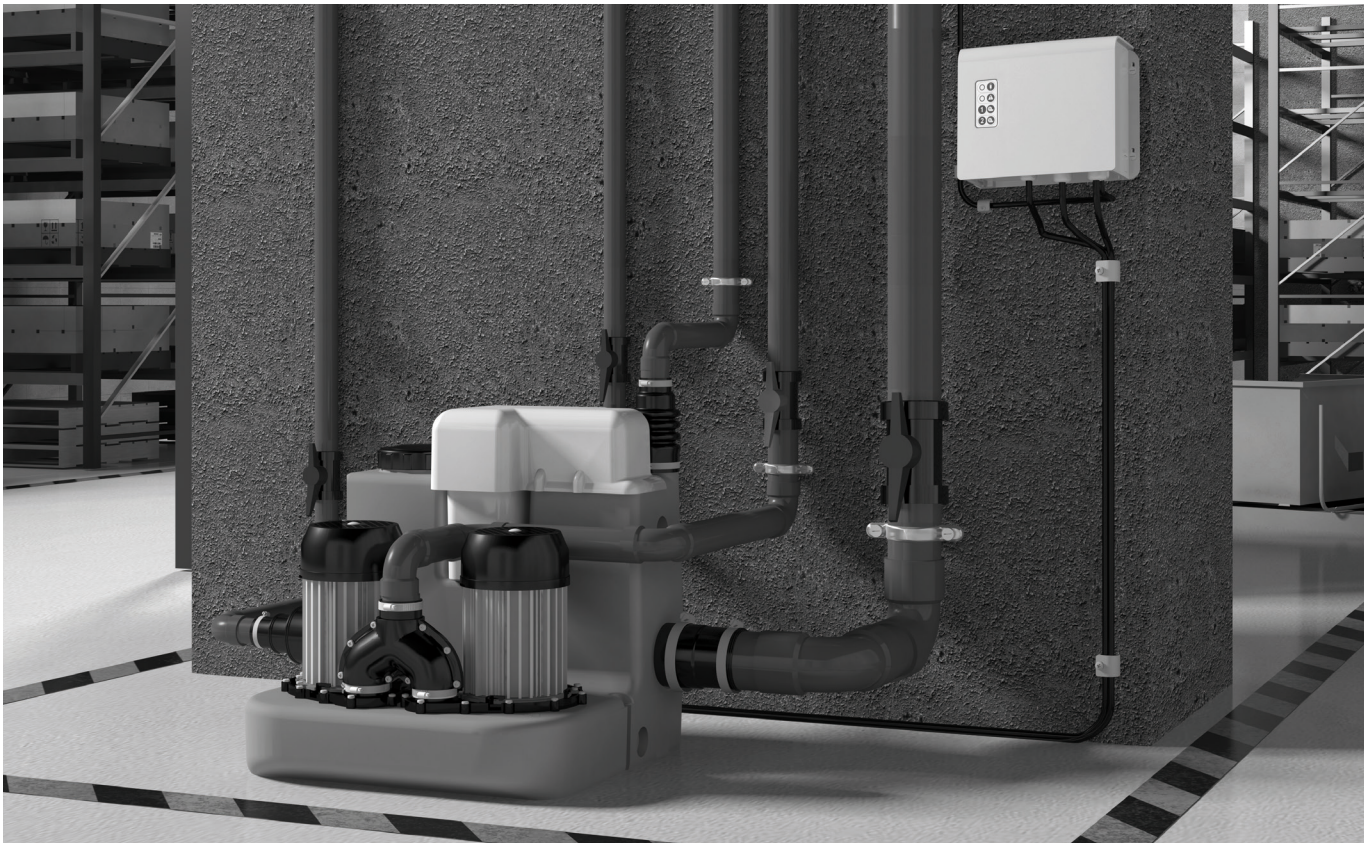

- A lire attentivement et à conserver à titre d'information • Bitte aufmerksam durchlesen und aufbewahren •
Da leggere attentamente e conservare a titolo di informazione • Dit document goed doorlezen en bewaren •
To be read and kept for information • Leer atentamente y conservar a título de información •
Leia atentamente este manual e guarde-o a título de informação •
Внимательно прочитать и сохранить в порядке информации •
• Do uważnegoprzeczytania i zachowania tytułem informacji • Instrucciones de instalación manual de instalação •
请认真阅读，并保留信息 • • Prosíme o důkladné prostudování a uschování •
• Att läsas och sparas för information



NOTICE D'INSTALLATION • INSTALLATIONSHINWEISE • ISTRUZIONI PER L'INSTALLAZIONE INSTALLA-
TIE VOORSCHRIFTEN • INSTALLATION INSTRUCTIONS • ИНСТРУКЦИЯ ПО УСТАНОВКЕ • INSTRUCCIONES DE INSTALACIÓN MANUAL DE INSTALAÇÃO • INSTRUKCJA INSTALACJI • NÁVOD K INSTALACI
A POUŽÍVÁNÍ

SANICOM® 2

1

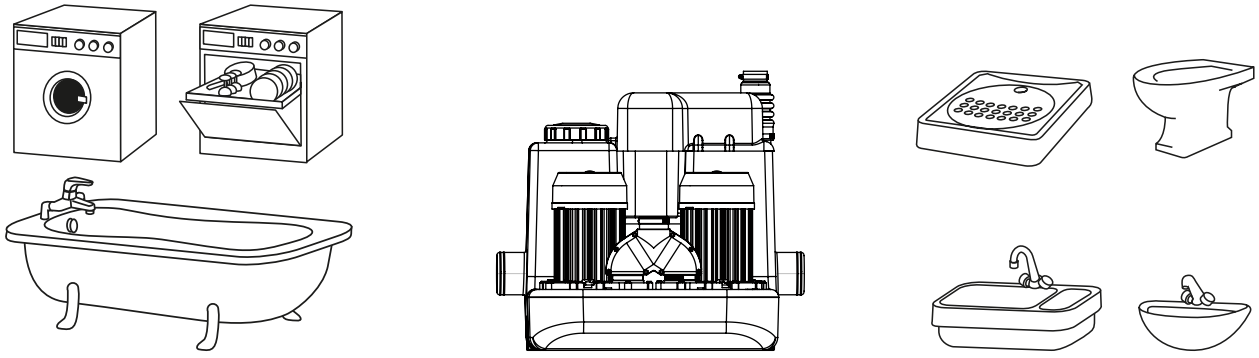

2

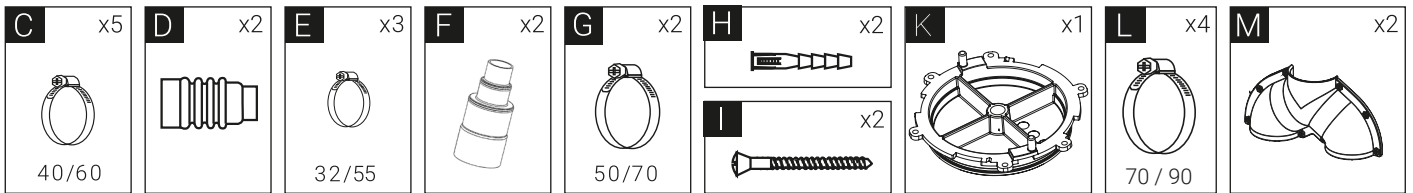

3

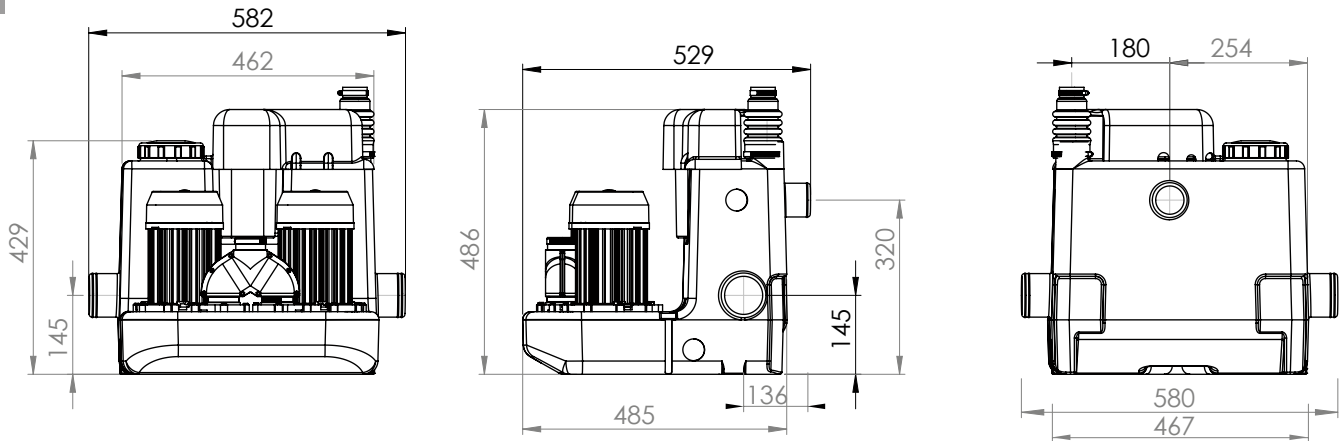

6

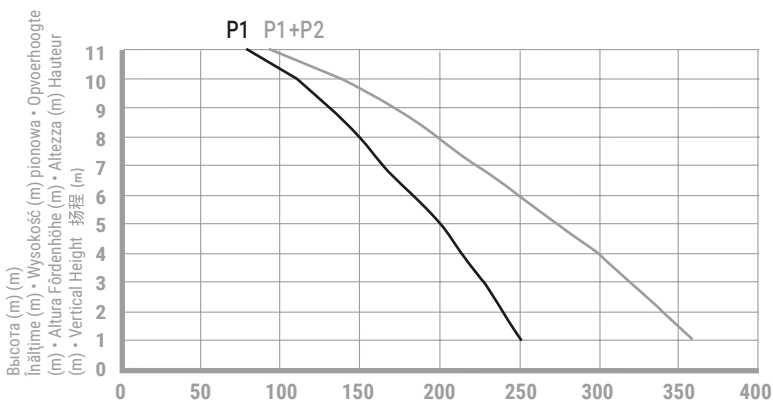

P1 Débit (l/min) avec 1 moteur • Flow Rate with 1 motor (l/min) • Flöde med 1 motor (l/min)
Förderstrom (l/min) mit 1 Motor • Portata con 1 motor (l/min) • Caudal (l/min) con 1 motor
Afvoercapaciteit met 1 motor (l/min) • Caudal (l/min) con 1 motor
Производительность (л/мин.) с 1 мотором • Wydajność (l/min) z jednym silnikiem
Yhden moottorin tuotto (l/min) • Debit (l/min) cu 1 motor • Čerpačí výkon (l/min) s 1 motorem

P1+P2 Débit (l/min) avec 2 moteurs • Flow Rate with 2 motors (l/min) • Flöde med 2 motorer (l/min)
Förderstrom (l/min) mit 2 Motoren • Portata con 2 motori (l/min)
Afvoercapaciteit met 2 motoren (l/min) • Caudal (l/min) con 2 motores • Caudal (l/min)
con 2 motores • Производительность (л/мин.) с 2 моторами • Wydajność (l/min)
z dwoma silnikami • Kahden moottorin tuotto (l/min)
Čerpačí výkon (l/min) s 2 motory • Debit (l/min) cu 2 motoare • 流量 (l/min)

7

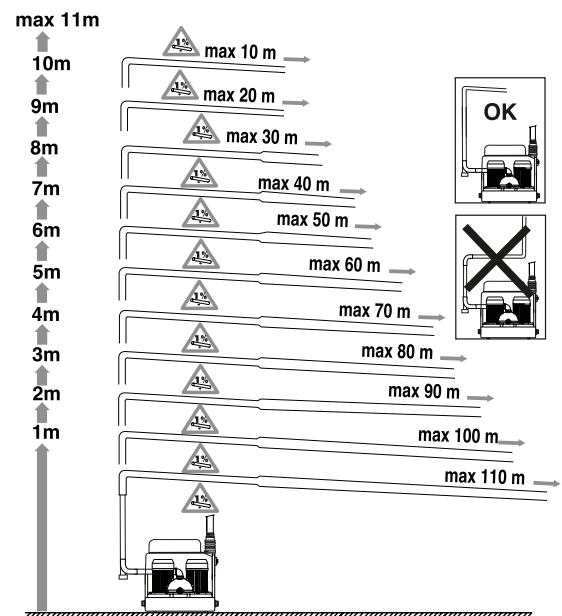

1 DESCRIPTION

SANICOM® 2 is a lifting station designed to evacuate grey water from small private or commercial units.

Please follow all the installation and maintenance instructions given here.

SAFETY

All personnel involved with the installation, operation, servicing and inspection of the SANICOM® 2 must be suitably qualified for this work and must have studied the installation manual to ensure that they are conversant with the pump installation and safety regulations. If the personnel do not have the necessary skills they should not attempt to install, operate, service or inspect this pump. This pump cannot be installed, operated, serviced or inspected by children or by people with reduced physical, sensory or mental capacity.

For all additional information please contact our customer support service.

OPERATION

SANICOM® 2 contains 2 independent pumps. The 2 pumps alternate in operation, in alternation. In the event of abnormal operation, the 2 motors operate simultaneously (or if one of the pumps is defective, the other takes over).

The SANICOM® 2 tank has 2 pressure tubes, one controlling the activation of the motor and the other the alarm system.

• Long pickup tube

During normal operation, as soon as the grey water reaches the triggering level of the long tube in the tank, the pump system starts up.

• Short pickup tube

During abnormal operation, if the effluent reaches the upper level in the tank (short tube), and audible and visual alarm is triggered and the pump system starts.

Installation - Alarm connection **14**.

2 LIST OF PARTS SUPPLIED**3 DIMENSIONS****4 TECHNICAL DATA ON SANICOM® 2**

Type	R90
Maximum vertical pumping	11 m
Voltage	220-240V
Frequency	50-60 Hz
Nominal Power Rating	3000 W
Maximum Power Consumption	13 A
Electrical category	I
Ave water temp for optimum performance	35°C
Maximum temperature intermittent (max 5 min)	90°C
Net weight (accessories included)	26 KG

5 FIELD OF APPLICATION

SANICOM® 2 is designed for disposing of wastewater originating from sinks, clothes washing machines, dishwashers, showers or baths and basins (private or commercial use).

6 PERFORMANCE CURVE**7 RATIO OF HEIGHT/LENGTH FOR DISCHARGE****8 INSTALLATION**

The SANICOM® 2 installation must comply with EN12056 standards. All work to install the equipment, put it into service and carry out maintenance must be done by a qualified professional specialist.

8a FITTING**I 1 | WARNING**

The space in which SANICOM® 2 is installed must be large enough to leave at least 600mm around the unit for easy maintenance. This space must be well lit, ventilated, and must never be immersed in water and must be protected from frost.

I 2 | Isolation valves should be fitted to the inlet pipework and discharge pipework to isolate the unit in case of the need for service.

I 3 | This discharge pipe must be designed so as to prevent back-flow from the sewers (see examples, sketch **3f**). Backflow is avoided by installing an anti-backflow loop located above the back-flow level.

Comment: Unless otherwise stated locally, the backflow level corresponds to the level of the roads or pavements, etc.

I 4 | We recommend installing an auxiliary pump to drain the pit if necessary (e.g. in the event of flooding).

8b CONNECTING THE DISCHARGE PIPE

The waste from SANICOM® 2 can be discharged through a 50 mm outside diameter plastic (or PVC, ABS, etc.).

Horizontal discharge pipework should maintain a 1% fall (1cm/M) to the soil and vent pipe. If a vertical rise is required, this must be installed at the start of the run, before the horizontal section.

WARNING: take care that the discharge valve flap faces the direction of flow.

If the end of the discharge pipework is much lower than the unit, install a riser pipe about 80mm long from the highest point of the discharge run and fit an air admittance pipe on top (capable of withstanding at least 15psi pressure) to break the syphon. End the outlet pipe at the soil stack.

ATTENTION: be sure to fit retaining bracket **M. Each SANICOM® 2 pipe is equipped with an anti-backflow pipe.**

ATTENTION : Secure the PVC pipe of 40mm or 50mm to the outlet from the unit, and secure it.

8c CONNECTING THE 40/50mm INLET

I 1 | Cut off the end of the 50mm inlet with a saw, then secure the outside of the sleeve **D** using a clip **G**.

I 2 | The connection at the inlet may be made using 40mm or 50mm tubing. For a 50mm connection, cut off the small end of the sleeve **D** first.

I 3 | Push the tube into the end of the sleeve **D** and fix using a jubilee clip **C**.

8d CONNECTING SANITARY EQUIPMENT TO THE LOWER INLETS

I 1 | Saw off the end of the 80 mm outside diameter inlet then attach the outside sleeve **F** using a clip **L**.

I 2 | Connection at the inlet may be made using a 40 mm / 50 mm or 80 mm outside diameter pipe. For an 80 mm outside diameter connection, first cut off the small end of the sleeve **F**.

I 3 | Push the pipe into the end of the sleeve **F** and secure it with a Jubilee clip **C** or **E** or **L**.

If you want to install a shower or a bath at the same level as the SANICOM®2, you must make sure that the upper parts of the plugholes on the sanitary equipment are at least 250 mm above the floor on which the SANICOM®2 is standing.

8e CONNECTING THE AIR VENT PIPE

I 1 | The collection station must be ventilated up to above roof level using a pipe with an ND of at least 40 mm.

I 2 | Connect the wide end of the sleeve **D** to the tank outlet point and fix it using a jubilee clip **G**.

I 3 | 50 mm outside dia.: Push the 50 mm outside dia. pipe into the sleeve and secure it with a Jubilee clip **C**.

I 4 | Do not fit an air admittance valve on the air vent as it will prevent correct operation of the SANICOM® 2. Air must flow freely in both directions for the pump to operate.

8f FIXING THE TANK TO THE FLOOR

It comes with a floor-fixing system that prevents it from moving or turning.

I 1 | Mark the position of the fixing holes on the floor.

I 2 | Remove the tank, drill the floor using a 10mm Ø drill and insert the pins **L**.

I 3 | Reposition the tank and fix it using the screws **L**.

8h ELECTRICAL CONNECTION

I 1 | The electrical installation work must be carried out by a qualified electrician. The electrical installation must comply with the standards in force in the country concerned.

I 2 | The power supply must be of the class 1 type. The unit must be connected via an earthed connection box. The electric power supply circuit must be protected by a high-sensitivity 30 mA differential circuit breaker rated at 20 A at the least.

The connection must be used solely to power the SANICOM® 2. If the power lead on the unit is damaged, it must be replaced by the manufacturer or its after-sales service to avoid all danger.

REGULATION: Comply with the provisions of the electric installation standard in force in the country of use.

9 STANDARDS

This piece of equipment complies with the EN 12050-2 standard (Lift station for effluents not containing faecal matter) and the directives and European standards on electric safety and electromagnetic compatibility.

The DoP can be consulted on our Internet website in the product data sheet ("Diagrams and technical datasheet" tab).

The installation and use of this unit must comply with European installation standards EN12056 and with local requirements.

10 COMMISSIONING

Once the hydraulic and electrical connections have been made, check that the connections are water-tight by allowing water to flow through each entry point used. Make sure the unit is operating correctly by carrying out at least 2 test pumping cycles with water.



11 USE

I 1 | SANICOM® 2 is designed to evacuate effluent from small private or commercial units. Any other application of the product may render the guarantee void. Never use it for paper towels, condoms or sanitary items, oils, solvents, waste products, acids, bases, other liquids that could cause an explosion, corrosive products, etc.

I 2 | WARNING

In the event of a power failure, turn off all water flowing into appliances connected to SANICOM® 2.

I 3 | Do not install or use the unit in an area presenting risks of explosion.

12 MAINTENANCE

Visually check that the collection station is operating properly at least once every month and have it checked regularly (annually) by qualified personnel. However, if there are any technical issues, ask your after sales supporting service for advice.

13 GUARANTEE

SANICOM® 2 is guaranteed for two years for parts and labour provided it is both installed and used in accordance with the current instructions.

14 ALARM (as an option)

ATTENTION

The alarm module is powered at 230V. Attach the module to the wall before connecting the device to the power supply. If the water level inside the device is abnormally high: the red LED lights up + the buzzer sounds. If the problem stops, the LED and the buzzer are deactivated.

15 OPERATION OF REMOTE UNIT

I 1 | GENERAL ALARMS

Level alarm

If the water level in the appliance is abnormally high: triggering of siren + lighting of red alarm LED + starting of the other motor 3 seconds later

Time alarm

If one of the 2 motors runs for more than 1 minute: triggering of siren + lighting of red alarm LED + starting of the other motor 3 seconds later

Mains alarm

In the event of a power cut (or when the appliance is disconnected): triggering of siren + lighting of red alarm LED + flashing of the yellow mains LED

I 2 | GENERAL ALARM RESET

If the issue that caused one of the above alarms to trigger appears, the siren will stop but the red alarm LED will stay on to memorise the fact that the system encountered a problem (flashing lamp if the source of the alarm was the alarm pressure switch and if the level pressure switch is defective). One of the two buttons of the keyboard will stop the siren in all cases but will not turn off the red LED unless the issue which caused the alarm to trip has been dealt with. This is a way of avoiding the system being forgotten by mistake.

"Mains" LED

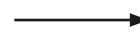

"Alarm" LED



"Motor 1" forced operation



"Motor 2" forced operation



OPTION

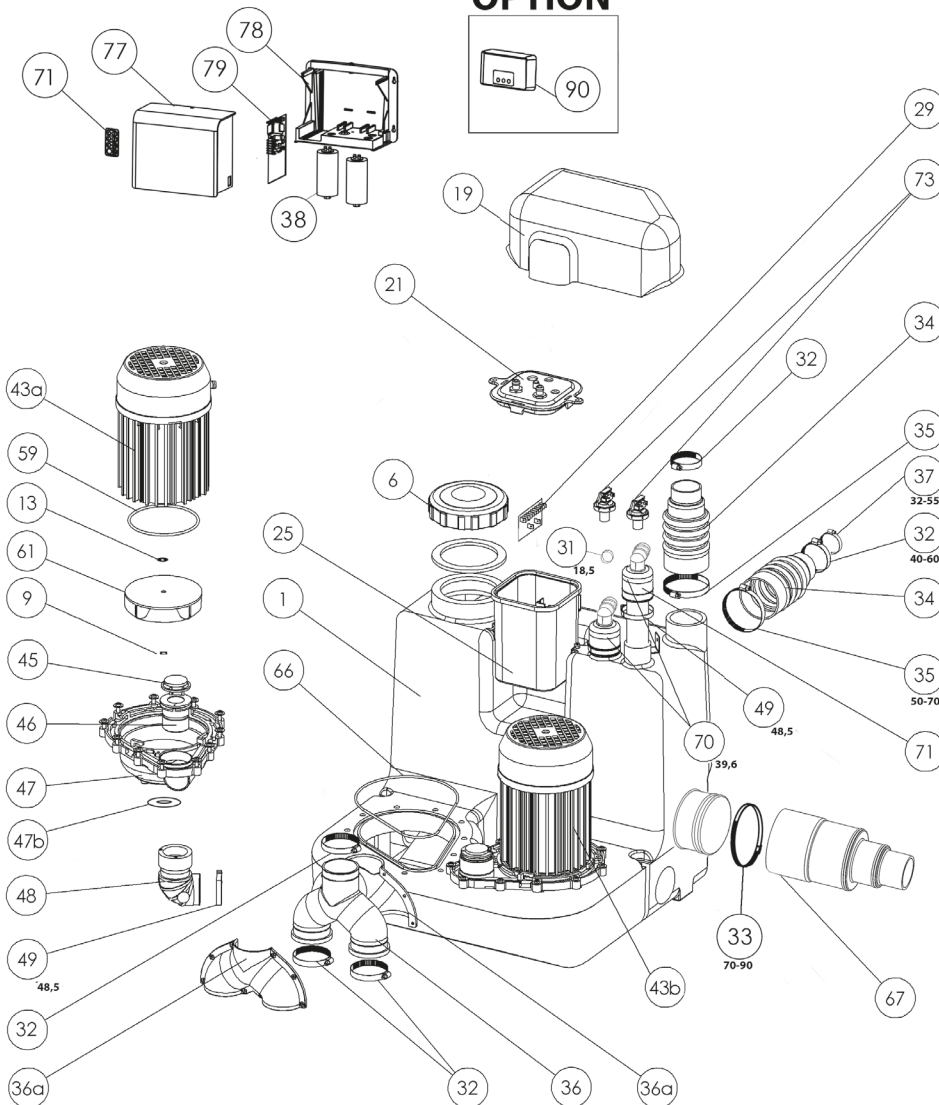

SANICOM® 2

OPTION

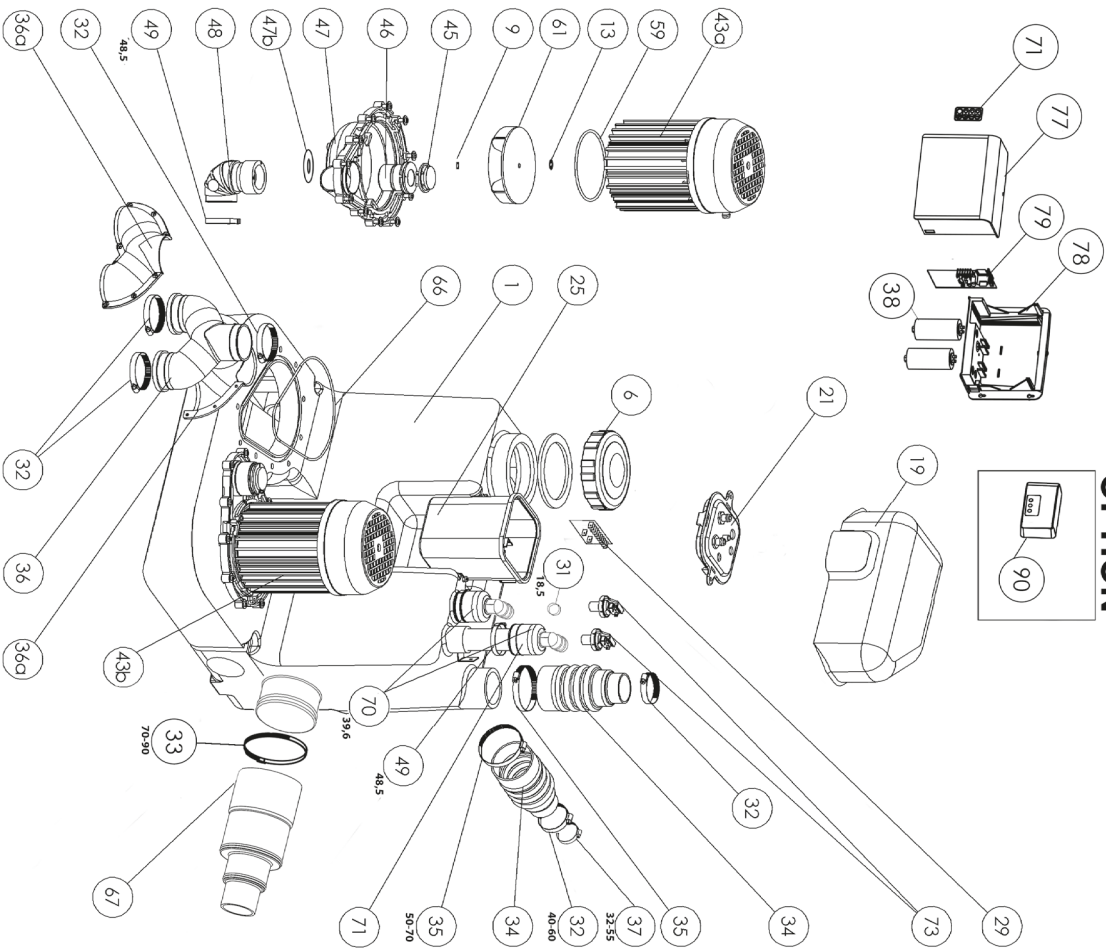

FRANCE

**SOCIÉTÉ FRANÇAISE
D'ASSAINISSEMENT**
8, rue d'Aboukir
75002 Paris
Tel. 01 44 82 39 00
Fax 01 44 82 39 01

UNITED KINGDOM

SANIFLO Ltd.,
Howard House,
The Runway
South Ruislip
Middlesex
HA4 6 SE
Tel. 020 8842 0033 / 4040
Fax 020 8842 1671

IRELAND

SANIRISH Ltd
IDA Industrial Estate
Ecdendry
County Offaly
Tel. +353 46 9733 102
Fax + 353 46 97 33 093

AUSTRALIA

SANIFLO AUSTRALIA
Unit 7, 15 Howleys Road,
Notting Hill
P.O. Box 5122
Pinewood Victoria 3149
Melbourne
Tel. +61 3 9543 3891
Fax +61 3 9543 6851

DEUTSCHLAND

SFA SANIBROY GmbH
Waldstr. 23 Geb. B5
63128 Dietzenbach
Tel. (060 74) 30928-0
Fax (060 74) 30928-90

ITALIA

SFA ITALIA spa
Via del Benessere, 9
27010 Sizzano (PV)
Tel. 03 82 61 81
Fax 03 82 61 8200

ESPAÑA

GRUPO SFA
C/ Vinylets 1
P.I. Can Vinylets
08130 Sta. Perpètua de
Mogoda - Barcelona
Tel. +34 93 544 60 76
Fax +34 93 462 18 96

PORTUGAL

SFA Lda
Av 5 de Outubro, 10 -1º
1050-056 Lisboa
Tel. +351 21 350 70 00
Fax +351 21 957 70 00

SUISSE SCHWEIZ SVIZZERA

SFA SANIBROY AB
SWITZERLAND
Stettensstrasse 6
CH-8954 Geroldswil
Tel. +41 44 748 17 44
Fax +41 44 748 17 43

BENELUX

SFA BENELUX B.V.
Vollweg 4
6101 XK Echt
Tel. +31 475 487100
Fax +31 475 486515

SVENIGE

SANIFLO AB
Box 797
S-191 27 Sollentuna
Tel. +08-404 15 30
Fax + 08-404 15 39

POLSKA

SFA POLAND
ul. Kolejowa 33
05-092 Lorkiniki/Warszawa
Tel. (+4822) 732 00 32
Fax (+4822) 751 35 16

РОССИЯ

SFA РОССИЯ
101000 Москва
Компанийный пер.
9а, ком. 103
Тел. (495) 258 29 51
факс (495) 258 29 51

ČESKÁ REPUBLIKA

SFA-SANIBROY, spol. s r.o
Na Košínce
180 00 PRAHA 8 - Libeň
Tel.: +420 266 712 855
Fax.: +420 266 712 856

ROMANIA

SFA SANIFLO S.R.L.
Strada Leonard Nicolae, nr. 2A
Timisoara 300454
Tel. +40 256 245 092
Fax +40 256 245 029

中国

升利保
宁波舒福安卫浴设备有限公司
宁波市鄞州区雅颂南路480号315153
T. 0574 - 8817 1777
F. 0574 - 8728 1907

SERVICE HELPLINES

TEL

France
United Kingdom
Ireland
Australia
Deutschland
Italia
España
Portugal
Suisse Schweiz Svizzera
Benelux
Sverige
Polska
Россиа
Česká Republika
România
中国

TEL
▶ N°Azur 0 810 05 90 02 / UT par appel
08457 650011 (Call from a land line)
1850 23 24 25 (LOW CALL)
+61 3 9543 3891
0800 82 27 82 0
0382 6181
+34 93 544 60 76
+351 21 350 70 00
+41 44 748 17 44
+31 475 487100
08-744 15 18
(+4822) 732 00 33
(+95) 258 29 51
+420 266 712 855
+40 256 245 092
+0574 - 8817 1777

FAX

03 44 94 46 19
020 8842 1671
+ 353 46 97 33 093
+61 3 9543 6851
(060 74) 30928-90
+39 0382 618200
+34 93 462 18 96
+351 21 957 70 00
+41 44 748 17 43
+31 475 486515
08-744 15 18
(+4822) 751 35 16
(495) 258 29 51
+420 266 712 856
+40 256 245 029
+0574 - 8728 1907

Service information : www.sfa.biz