



Te Kāhui
Whaihanga
New Zealand
Institute of
Architects



Building Code Clause(s) B1

PRODUCER STATEMENT – PS1 – DESIGN

ISSUED BY: PreStressed Timber Limited
(Design Firm)

TO: SPAX Pacific Pty Ltd
(Owner/Developer)

TO BE SUPPLIED TO: all Building Consent Authorities
(Building Consent Authority)

IN RESPECT OF: Boundary Joists and Baluster Post Fixing for Decks
(Description of Building Work)

AT: Any address for buildings included in the scope of NZS 3604
(Address)

Town/City: NA (Address) **LOT** NA **DP** NA **SO** NA

We have been engaged by the owner/developer referred to above to provide:

alternative design for Boundary Joists and Baluster Post Fixing for Decks with SPAX screws based on test results and calculations

(Extent of Engagement)

services in respect of the requirements of Clause(s) B1 of the Building Code for:

All or Part only (as specified in the attachment to this statement), of the proposed building work.

The design carried out by us has been prepared in accordance with:

Compliance Documents issued by the Ministry of Business, Innovation & Employmentor
(verification method/acceptable solution)

Alternative solution as per the attached schedule 0427NZL - E001_B, dated 8/05/2020 (Test results and calculations)

The proposed building work covered by this producer statement is described on the drawings titled:

Timber Construction Application Sheet No. 4, dated July 2020and numbered pages 1-4;
together with the specification, and other documents set out in the schedule attached to this statement.

On behalf of the Design Firm, and subject to:

- (i) Site verification of the following design assumptions in schedule 0427NZL - E001_B, dated 8/05/2020
- (ii) All proprietary products meeting their performance specification requirements;

I believe on reasonable grounds that a) the building, if constructed in accordance with the drawings, specifications, and other documents provided or listed in the attached schedule, will comply with the relevant provisions of the Building Code and that b), the persons who have undertaken the design have the necessary competency to do so. I also recommend the following level of construction monitoring/observation:

CM1 CM2 CM3 CM4 CM5 (Engineering Categories) or as per agreement with owner/developer (Architectural)

I, Andrew Hamilton Buchanan am: CPEng 35961 # Reg Arch #
(Name of Design Professional)

I am a member of: Engineering New Zealand NZIA and hold the following qualifications:.....

The Design Firm issuing this statement holds a current policy of Professional Indemnity Insurance no less than \$200,000*.

The Design Firm is a member of ACENZ:

SIGNED BY Andrew Hamilton Buchanan (Signature) 
(Name of Design Professional)

ON BEHALF OF PreStressed Timber Limited Date 07/07/2020
(Design Firm)

Note: This statement shall only be relied upon by the Building Consent Authority named above. Liability under this statement accrues to the Design Firm only. The total maximum amount of damages payable arising from this statement and all other statements provided to the Building Consent Authority in relation to this building work, whether in contract, tort or otherwise (including negligence), is limited to the sum of \$200,000.*

This form is to accompany **Form 2 of the Building (Forms) Regulations 2004** for the application of a Building Consent.
THIS FORM AND ITS CONDITIONS ARE COPYRIGHT TO ACENZ, ENGINEERING NEW ZEALAND AND NZIA

SPAX boundary joist and post fixing solution

Construction Outdoor

- Three times faster installation than other methods
- Cost effective
- No brackets or coach screws required
- Higher load capacity allowing larger baluster spacings
- Exceptional durability with A4/316 stainless steel
- Aesthetically appealing
- PS1 Producer Statement available on request

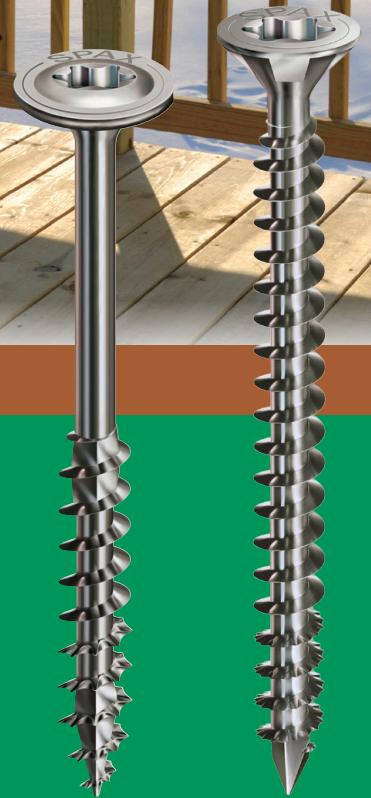

SPAX Boundary Joist and Post System

Item	Description	Drive-Bit Size	SPAX No.	EAN No.
	SPAX 10 x 200 A4 CS F/T	T50	1208001002000	4003530182303
	SPAX 10 x 240 A4 CS. F/T	T50	1208001002400	4003530178689
	SPAX 8 x 120 A2 W/H	T40	0257000801200	4003530242595
	SPAX 8 x 180 A2 W/H	T40	0257000801800	4003530242625
	SPAX Drill-bit Ø 6.0 x 250 HSS-G		2000000250060	4026271029881
	SPAX Boundary Joist Pre-Drill Guide 15°		3000001000015	0794712213543
	SPAX T-STAR plus T40		5000009182409	4003530239687
	SPAX T-STAR T50		5077701515035	4003530161582

Complies with strength and deflection requirements of NZS 3604 and AS/NZS1170

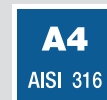

Boundary Joist and Baluster Post Fixing for Decks (cont.)



Setup for face-fixed baluster posts

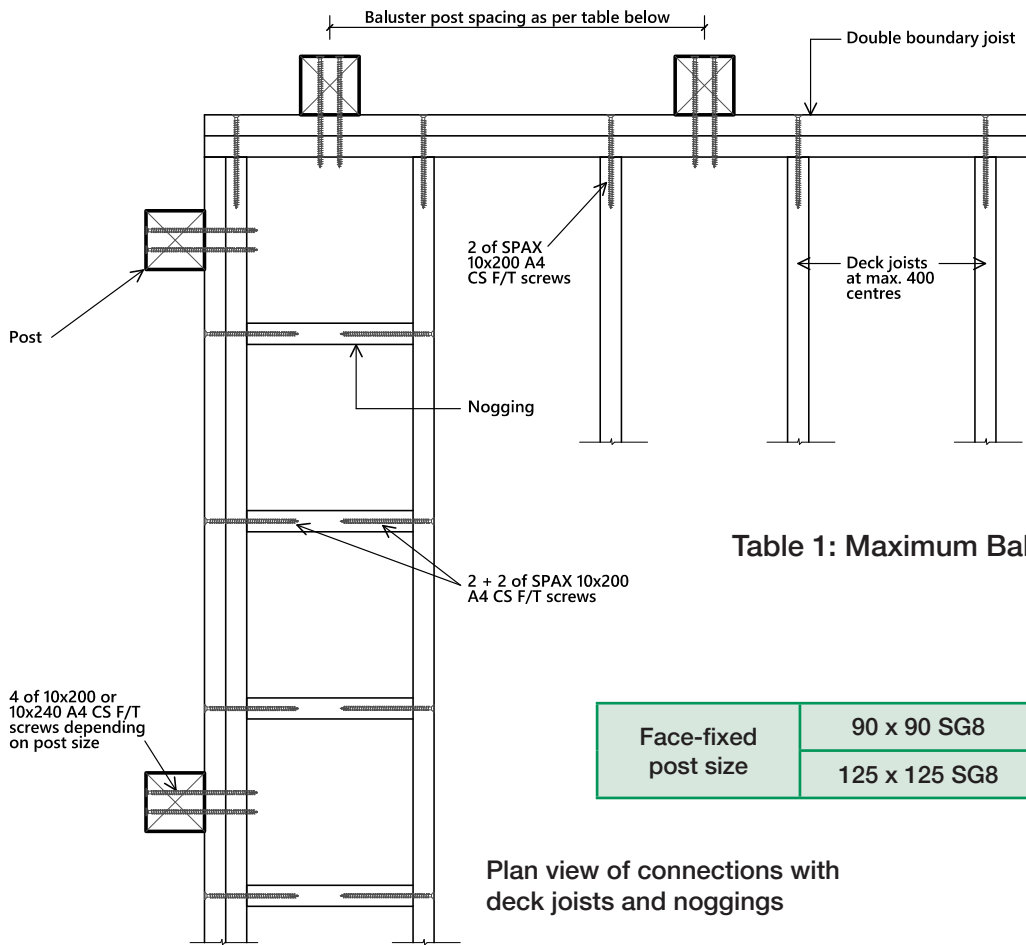
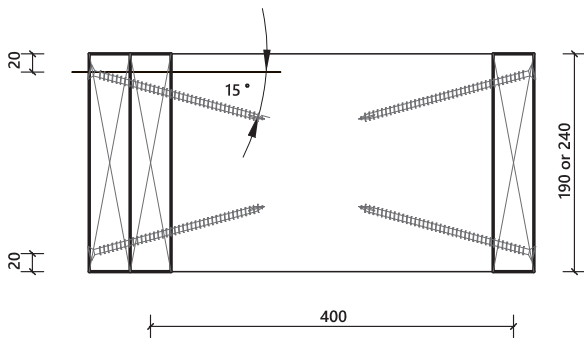

Table 1: Maximum Baluster Post Spacing (m)

		Joist Size	
		190 x 45	240 x 45
Face-fixed post size	90 x 90 SG8	1.0 m	1.0 m
	125 x 125 SG8	1.4 m	1.8 m

Plan view of connections with deck joists and noggings



Elevation of boundary joist connection to noggings

Plan view of baluster post connection to boundary joist

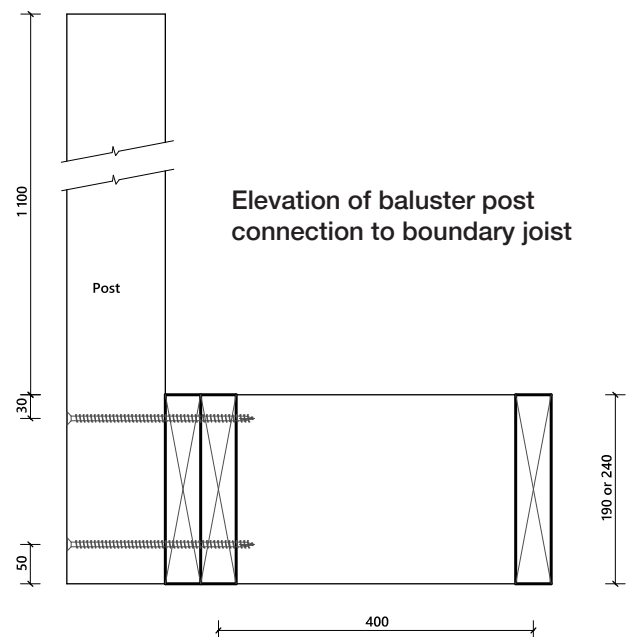
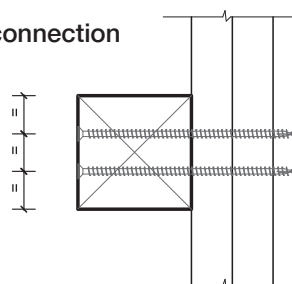

Elevation of baluster post connection to boundary joist

Boundary Joist and Baluster Post Fixing for Decks (cont.)



Installation instructions with face-fixed baluster posts

Double boundary joist:

Screws required

For deck joist - 2 of SPAX 10 x 200 A4 CS F/T plus 1 of SPAX 180mm long DELTA-SEAL WH

For noggings - 4 of SPAX 10 x 200 A4 CS F/T plus 2 of SPAX 180mm long DELTA-SEAL WH

1. Hold the first (inner) boundary joist in place with either nails or screws into deck joists and noggings no more than 20mm from top and bottom of the boundary joist.
2. Install a SPAX 180mm DELTA-SEAL WH screw of any diameter through the outer boundary joist into the mid-point of the deck joist or nogging to clamp the timbers together.
3. Pre-drill two 6mm diameter holes to a depth of at least 150mm at 20mm from the top and bottom of the joist at an angle of 15° as shown in the diagram. Use the SPAX boundary joist drilling template for an accurate angle.
4. Install two SPAX 10 x 200 A4 CS F/T screws in the pre-drilled holes.
5. Remove the WH screw from the mid-point (this can be re-used a couple of times).
6. For noggings, repeat steps 2 to 5 at the rear of the nogging.

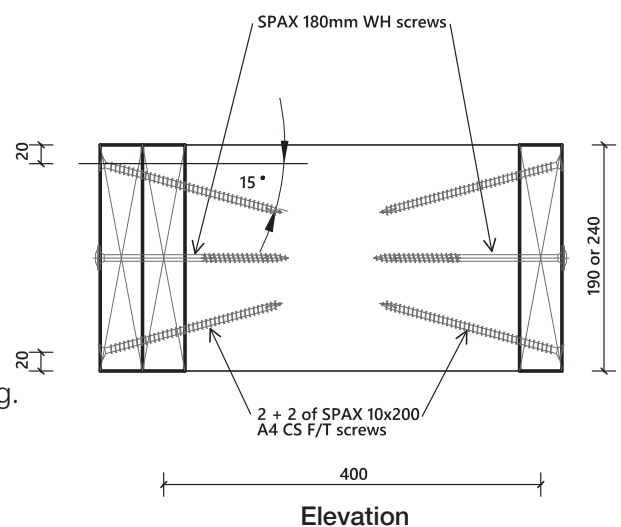

Baluster post:

Screws required

For 90mm post - 4 of SPAX 10 x 200 A4 CS F/T

For 125mm post - 4 of SPAX 10 x 240 A4 CS F/T

1. Clamp the post in place according to the spacing in table 1.
2. Install four SPAX 10mm A4 CS F/T screws through the post and the full depth of the boundary joists as shown in the diagram below, the length of the screw depending on the post thickness. The point of the screws protruding on the back of the joist can be cut off if desired.

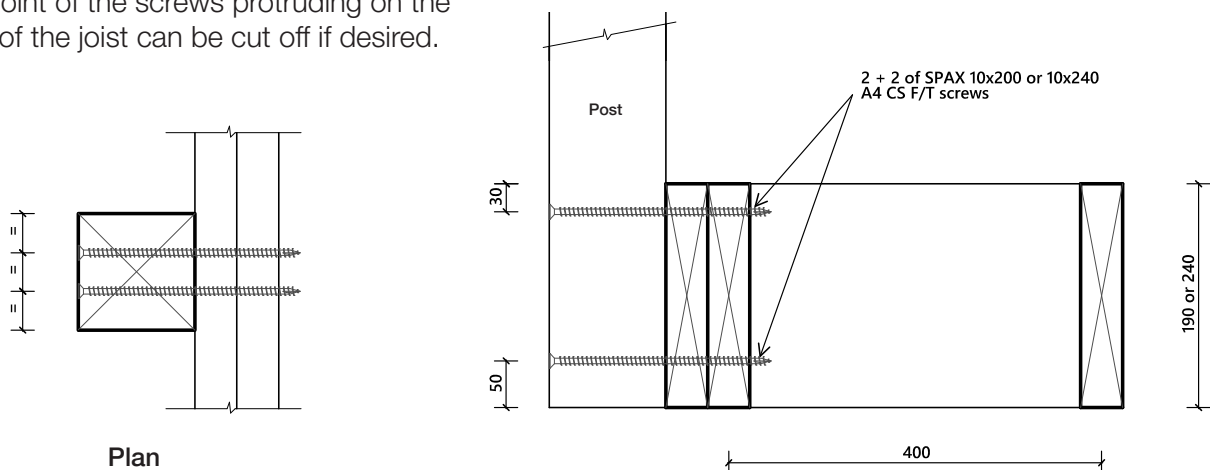

Boundary Joist and Baluster Post Fixing for Decks (cont.)



Installation instructions with top-fixed baluster posts

Double boundary joist:

Screws required

For deck joist - 2 of SPAX 10 x 200 A4 CS F/T plus 1 of SPAX 180mm long DELTA-SEAL WH

For noggings - 4 of SPAX 10 x 200 A4 CS F/T plus 2 of SPAX 180mm long DELTA-SEAL WH

For blockings - SPAX 8 x 120 A2 WH (quantity as per Table 2 below)

1. Install double boundary joist as per face-fixed baluster posts.
2. Attach timber blocking to inside of the boundary joist to accommodate the top-fixed post using the 8 x 120 stainless steel washer head screws as per the table and figures below. For pre-drilled holes, use a 5mm drill bit and drill to 120mm depth.

Table 2: No. of SPAX 8 x 120 A2 WH screws required

		Top-fixed post spacing				
		1.0 m	1.2 m	1.4 m	1.6 m	1.8 m
No. of screws	Pre-drilled hole	6	7	8	9	10
	Non pre-drilled	7	9	10	12	13

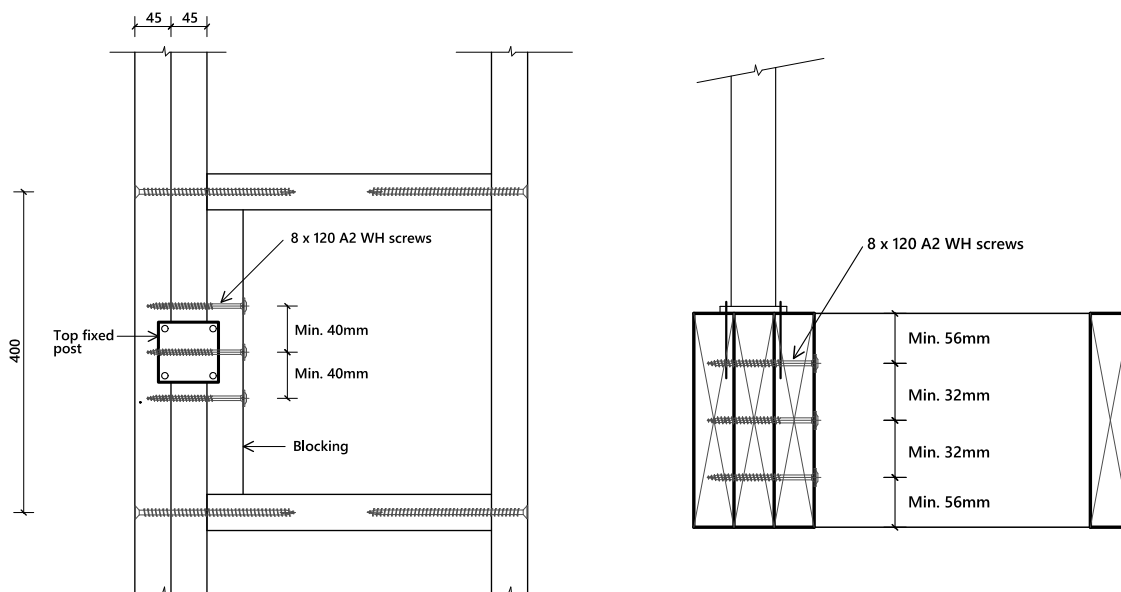

Baluster post:

Install as per proprietary baluster supplier details using maximum post spacing as on right.

Table 3: Maximum Baluster Post Spacing (m)

	Joist Size	
	190 x 45	240 x 45
Top-fixed post	1.4 m	1.8 m

This specification is for timber of grade SG8 or better. For more information, please contact us using the details below.