

Saniflo  SFA GROUP

Designer Hub



Shaking up water



A large, dynamic splash of water in shades of blue and white, cascading from the top right towards the bottom left, set against a solid blue background.

Quick Links

- 1 Bim Object Technical Files 
- 2 Case Studies
- 3 Blogs
- 4
- 5

What are the questions I need to ask before I specify a pump?

1. What is the type of application?

- Domestic or commercial

2. What fixtures are being attached to the pump?

This determines whether it is a macerator, grey water pump or lifting station that will be required.

- For kitchen sink, shower, hand basin, bath and laundry refer to Grey Water Pump
- For toilets combined with grey water attachments refer to Macerator
- For toilet suite with macerator refer to Integrated Macerator
- For high-temperature waste, multiple fixtures, or high lift refer to Lifting Stations

3. If it is a commercial application, is there a commercial dishwasher or glasswasher discharging to the pump?

- Please specify Sanicom 1 /Sanicom 2

4. How high does the waste need to be pumped?

- Refer to the pumping height with the flow chart





















5. How far away does the waste need to travel?

- Refer to the product sheets with the flow chart

Specifying a pump can sometimes be a complex process, we often need further information to understand the installation better:

- How many changes of direction are there along the discharge line?
NB: No 90 degree angle bends, only 45 degree angles.
- Is there any fall at the top of the vertical lift?

PLEASE NOTE: If you cannot achieve the vertical pumping distance and if the installation parameters are outside the guidelines please call our technical department AU 1300 554 779 and NZ 0800 107 264.

MODEL NO	PRODUCT NAME	POSSIBLE CONNECTIONS	PUMPING HEIGHT	PAGE	APPLICATION		
					COMMERCIAL	DOMESTIC	
GREY WATER PUMP					9		
SA 112/113/114	SANIFLOOR +		3m	10	LIGHT 	 bimobject®	
SA 94	SANISHOWER +	 	5m	11	LIGHT 	 bimobject®	
SA 95	SANIVITE +	     	5m	12	N/A	 bimobject®	
SA 101	SANISPEED +	     	7m	13	LIGHT 	N/A  bimobject®	
MACERATOR					15		
SA 80	SANIACCESS 2	 	5m	16	LIGHT 	 bimobject®	
SA 81	SANIACCESS 3	  	5m	17	LIGHT 	 bimobject®	
SA 99	SANIPACK PRO UP	  	5m	18	LIGHT 	 bimobject®	
SA 97	SANITOP	  	5m	19	LIGHT 	 bimobject®	
SA 98	SANIPLUS	    	5m	20	LIGHT 	 bimobject®	
SA 96	SANIPRO	   	5m	21	LIGHT 	 bimobject®	
SA 100	SANIBEST PRO	    	7m	22	HEAVY	N/A  bimobject®	
INTEGRATED MACERATOR					24		
SA 106	SANICOMPACT	 	3m	27	N/A	 bimobject®	
LIFTING STATION					28		
SA 102	SANICOM 1	     	8m	30	HEAVY	N/A  bimobject®	
SA 108	SANICOM 2	     	11m	31	HEAVY	N/A  bimobject®	
SA 107	SANICUBIC 1 WP	      	11m	32	LIGHT 	 bimobject®	
SA 104	SANICUBIC 2 PRO WP	      	11m	34	HEAVY	 bimobject®	
SA 111	SANICUBIC 2 VX SINGLE PHASE	      	10m	36	HEAVY	 bimobject®	
SA 300	SANICUBIC 1 GR	      	20m	38	HEAVY	 bimobject®	
CONDENSATE					40		
SA92	SANICONDENS PRO	 	4.5m	42	✓	✓ bimobject®	
SA110	SANICONDENS CLIM MINI S	 	6m	43	✓	✓ bimobject®	
SA91	SANICONDENS BEST FLAT	  	4.5m	44	✓	✓ bimobject®	
ADDITIONAL PRODUCTS					45		
ALARM 1	SANIALARM		N/A	46	✓	✓	
SANI12661	SANIALARM INTERLOCK		N/A	47	✓	✓	
DETAUST	SANIDESCALER		N/A	48	✓	✓	
DN100	SANIKNIFE VALVE		N/A	48	✓	✓	

 Domestic application  Commercial application Light = Light commercial Heavy = Heavy commercial

Saniflo a group SFA company. The leaders in pumping technology.



Founded in France in 1958, SFA developed the first ever macerator pump, a product that revolutionised the bathroom renovation market and shaped the company's history.

The macerating toilet pump was an immediate success. It enabled a bathroom to be installed anywhere in the home without the need of direct access to a sewer point. As homes are mostly brick and concrete structures, it was both difficult and costly to relocate or extend sewer pipes.

The SFA macerator filled a demand for extra wet areas in the home, without the cost and inconvenience of moving sewer pipes. It is achieved by finely chopping the incoming waste so that it can be pumped through small diameter pipework.

The benefit of using small diameter pipework is that it can be concealed behind the walls, under floors or in ceiling spaces and eventually connected to the existing sewer line.

After achieving unwavering success in Europe with its macerators, grey water pumps and lifting stations, SFA continues to expand its unique offering around the world. The group established itself with the Saniflo brand in Australia and has never looked back. With growing popularity in basement living, outdoor BBQ kitchens, additional toilet and granny flat extensions, there is an ever increasing demand for cost effective plumbing solutions.

Despite a global presence, Saniflo is dedicated to the same principles that underpinned its initial success: innovation and quality. Products are made to the highest standards by Saniflo's parent company in France, using modern production technology and our team of engineers consistently develop products that meet the requirements of modern decor.

Saniflo's macerator fills a demand for extra wet areas in the home, without the cost and inconvenience of moving sewer pipes.





Install a kitchen or laundry without major plumbing work

Make the most of your living spaces with Saniflo and add a kitchen or laundry anywhere in the home. Install a laundry in the basement or sink in an alfresco area using a Saniflo grey water pump.

Grey water fixtures are connected to top and side inlets of the pump. As waste flows in, the pressure activated micro-switch senses the water level rising and starts the motor. The waste water is pumped out using a powerful 400w motor. The small-bore 25mm discharge pipe can be hidden behind plaster walls, under the floor or in ceiling spaces before it is connected to the existing sewer line.

Saniflo grey water pumps are also ideal in commercial situations where the sewer pipes are in a fixed location. This is common in office fit-outs, hair salons, cafes and restaurants where there are restrictions on altering the building structure. Using a Saniflo grey water pump, waste water can be easily pumped to the existing sewer line over long distances or heights.



Make the most of your living spaces with Saniflo's simple principle for adding a kitchen or laundry anywhere in the home.

Install a bathroom anywhere with a Saniflo maceratorator pump

With a growing family and frequent visitors, you may feel the need for an extra guest toilet or for luxury living you may want to install an ensuite. Saniflo has made that dream achievable with its wide range of macerators.

With Sanipack Pro UP you can now install that beautiful wall hung toilet that you always wanted. With additional inlets for vanity basin and shower, you can have a complete ensuite.

If you have limited space and just need a toilet with vanity basin, Sanicompact toilet suite is the answer. Its' compact design enables a toilet to be added where space is limited making it ideal for a small ensuite or powder room. It is the first toilet suite with 6-star WELS rating and uses 2.2 litres of water on average.



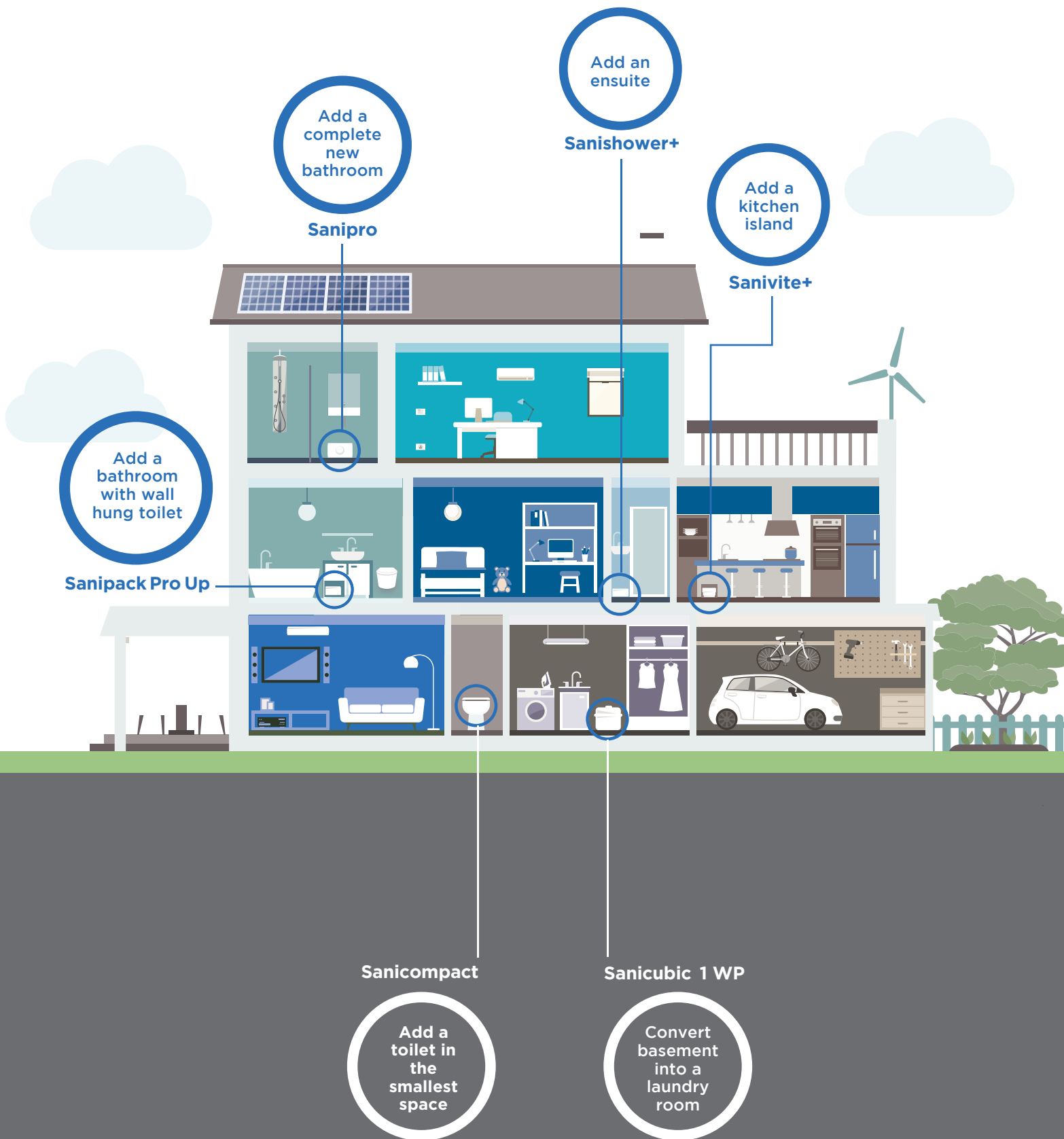



GREY WATER PUMP

MODEL NO	PRODUCT NAME	POSSIBLE CONNECTIONS	PUMPING HEIGHT	PAGE	APPLICATION	
					COMMERCIAL	DOMESTIC
SA 112/113/114	SANIFLOOR +		3m	8	LIGHT ●	●
SA 94	SANISHOWER +		5m	9	LIGHT ●	●
SA 95	SANIVITE +		5m	10	N/A	●
SA 101	SANISPEED +		7m	11	LIGHT ●	N/A

● Domestic application ● Commercial application Light = Light commercial Heavy = Heavy commercial

TIPS

- Sanispeed+ is not recommended for commercial applications where excessive fat, grease, citrus based cleaners, waxes, harsh chemicals, ammonia, bleaches, commercial dishwasher and glasswasher are used. (Use Sanicom 1 instead)



WMTS 106:2019
Certificate No. 23048
Manufacturer: SFA
Brand: Saniflo

PRODUCT REFERENCES:
SA112/SA113/SA114



Product sheet

Instruction sheet

Sanifloor®+

Sanifloor®+ allows a shower to be installed easily and economically without major work accessing sewer pipes. The pump sucks the water from the shower gully and discharges back to the existing sewer line. Installing a stylish walk-in shower is easy with a Sanifloor®+.

WHY CHOOSE THIS PRODUCT?

- Suits walk in showers and low level shower trays
- Ideal for high flow applications
- Pump and waste inlet can be up to 3 m apart horizontally
- Dual function - sucks waste up from the gully and pumps waste water away up to 3 m vertically or 30 m horizontally
- Pump can be positioned up to 300 mm above the gully
- All gully types are 90 mm in diameter
- Wireless activation
- 24mm OD suction pipe

VERTICAL/HORIZONTAL PERFORMANCE

Increase size of horizontal run by one pipe size after 5m. All horizontal pipework requires a minimum of 1:100 fall.

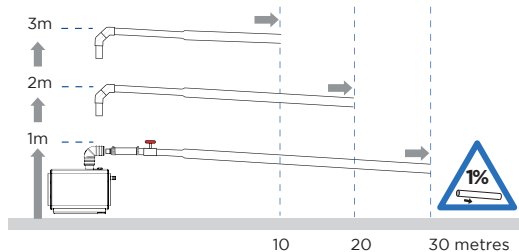

FLOW RATE PERFORMANCE CHART

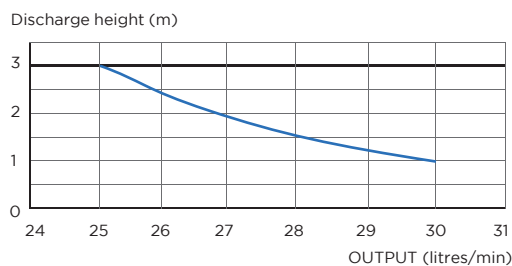

TECHNICAL CHARACTERISTICS



Discharge Pipework	25 mm
Motor Power	400 Watts
Voltages	220-240 V/50 Hz
Working Waste Water Temp	35°C
Product Weight	7.9 kg
Overall Measurements	295 x 191 x 164 mm
IP Rating	IP44

GULLY TYPES

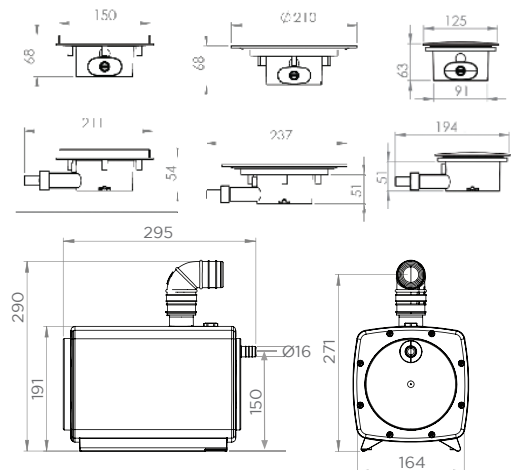
- Ref SA112:** With shower waste gully for vinyl floor - Height 68 mm
- Ref SA113:** With shower waste gully for tiled floor - Height 68 mm
- Ref SA114:** With shower waste gully for trays - Height 63 mm



NOTE: To maintain radio signal integrity pump must be installed in same room with power cable end facing towards shower waste gully.

Product sheet 
 Instruction sheet 



Sanishower®+

The low profile design enables the Sanishower®+ to be installed discreetly into a cabinet. Ideal for installing a shower and vanity.



WHY CHOOSE THIS PRODUCT?

Overcomes gravity drainage issues

Allows basement showers

Can be fitted next to shower tray

Additional inlet for basin

Includes integrated carbon filter

Low activation level (65 mm)

VERTICAL/HORIZONTAL PERFORMANCE

Increase size of horizontal run by one pipe size after 5m.
 All horizontal pipework requires a minimum of 1:100 fall.

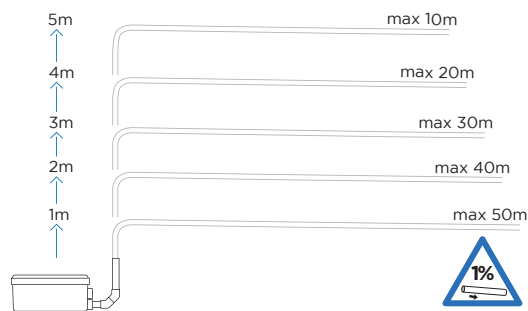

TECHNICAL CHARACTERISTICS

Discharge Pipework	20 mm
Motor Power	400 Watts
Voltages	220-240 V/50 Hz
Working Waste Water Temp	35°C
Product Weight	3.5 kg
Overall Measurements	359 x 146 x 166 mm
Inlet Pipework	40 mm
IP Rating	IP44
Activation Level	65 mm

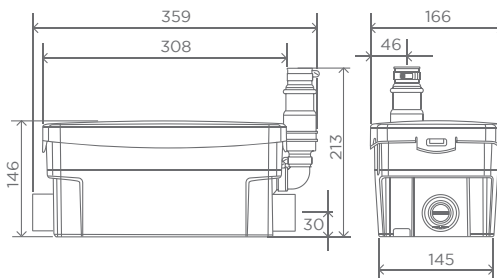

FLOW RATE PERFORMANCE CHART

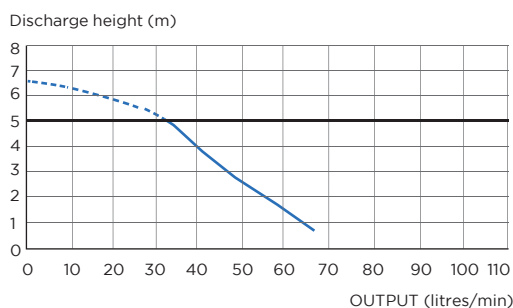

APPLICATIONS



HAND
BASIN



SHOWER



WMTS 106:2019
 Certificate No. 23048
 Manufacturer: SFA
 Brand: Saniflo

PRODUCT REFERENCE:
 SA94

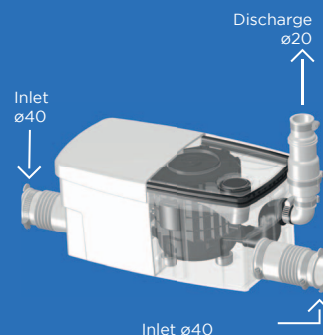

GREY WATER PUMP

Made in France to the
 highest standards,
 needs to be installed
 by a licensed plumber

APPLICATIONS



HAND BASIN



BATH



KITCHEN SINK



WASHING MACHINE



DISH WASHER



WMTS 106:2019
Certificate No. 23048
Manufacturer: SFA
Brand: Saniflo

PRODUCT REFERENCE:
SA95

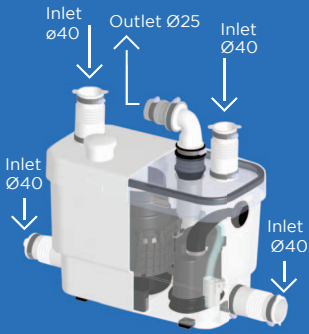

Product sheet

Instruction sheet

Sanivite®+

Ideal for kitchen, bath, outdoor BBQ kitchen or laundry. Sanivite®+ has up to four inlet connections making it the ideal solution for installing multiple plumbing fixtures.



TECHNICAL CHARACTERISTICS

Discharge Pipework	25 mm
Motor Power	400 Watts
Voltages	220-240 V/50 Hz
Working Waste Water Temp	35°C/Max 60°C (intermittent)
Product Weight	6.4 kg
Overall Measurements	367 x 277 x 189 mm
Inlet Pipework	40 mm
IP Rating	IP44

WHY CHOOSE THIS PRODUCT?

- Only for domestic application
- Powerful, quiet pump
- Low activation level (95 mm)
- Compact for concealed installation
- Carbon filter included to neutralise odours
- Working temperature of 35°C.
- Will handle up to 60°C for short periods (5 minutes)

VERTICAL/HORIZONTAL PERFORMANCE

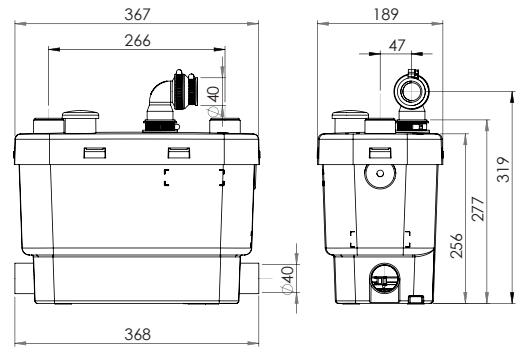
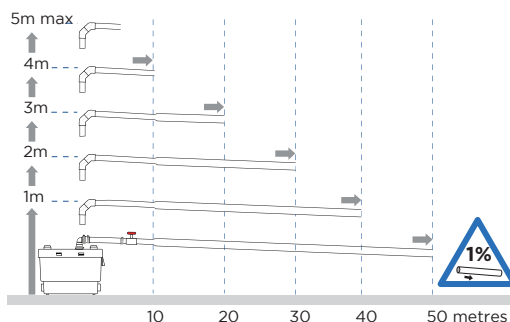

Increase size of horizontal run by one pipe size after 5m.
All horizontal pipework requires a minimum of 1:100 fall.

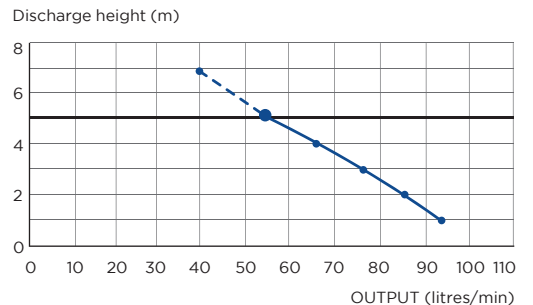

FLOW RATE PERFORMANCE CHART



Made in France to the highest standards, needs to be installed by a licensed plumber

Product sheet 
 Instruction sheet 



APPLICATIONS



HAND BASIN



BATH



SHOWER



KITCHEN SINK



WASHING MACHINE



DISH WASHER

GREY WATER PUMP



WMTS 106:2019
 Certificate No. 23048
 Manufacturer: SFA
 Brand: Saniflo

PRODUCT REFERENCE:
 SA101

Sanispeed®+

Ideal for light commercial environments such as small shops, cafes, offices, bars, automatic coffee machines and dental surgeries where grey water needs to be disposed of.



TECHNICAL CHARACTERISTICS

Discharge Pipework	25 mm
Motor Power	400 Watts
Voltages	220-240 V/50 Hz
Working Waste Water Temp	35°C/Max 75°C (intermittent)
Product Weight	6.4 kg
Overall Measurements	367 x 277 x 189 mm
Inlet Pipework	40 mm
IP Rating	IP44

WHY CHOOSE THIS PRODUCT?

- Ideal for light commercial applications
- Low activation level (95 mm)
- Can connect to Alarm or Alarm Interlock
- Four inlets - two side entries and two top entries
- Working temperature of 35°C
- Will handle up to 75°C for short periods (5 minutes)
- Carbon filter included to neutralise odours

VERTICAL/HORIZONTAL PERFORMANCE

Increase size of horizontal run by one pipe size after 5m. All horizontal pipework requires a minimum of 1:100 fall.

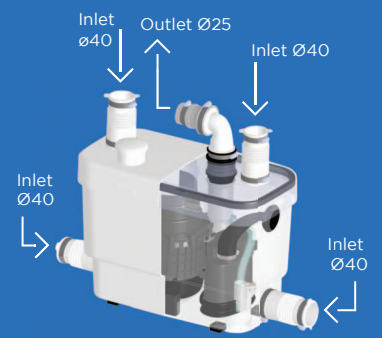
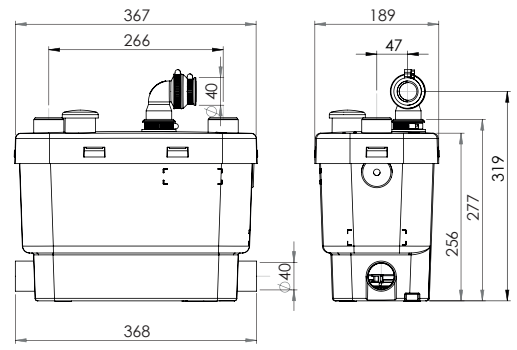
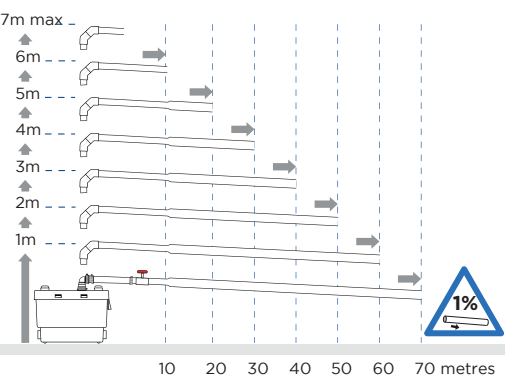

FLOW RATE PERFORMANCE CHART

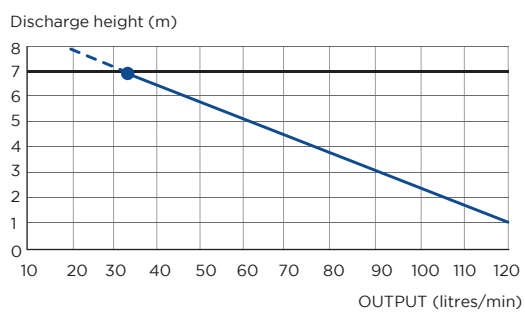

Made in France to the highest standards, needs to be installed by a licensed plumber

MACERATOR



MODEL NO	PRODUCT NAME	POSSIBLE CONNECTIONS	PUMPING HEIGHT	PAGE	APPLICATION	
					COMMERCIAL	DOMESTIC
SA 80	SANIACCESS 2		5m	15	LIGHT ●	●
SA 81	SANIACCESS 3		5m	16	LIGHT ●	●
SA 99	SANIPACK PRO UP		5m	17	LIGHT ●	●
SA 97	SANITOP		5m	18	LIGHT ●	●
SA 98	SANIPLUS		5m	19	LIGHT ●	●
SA 96	SANIPRO		5m	20	LIGHT ●	●
SA 100	SANIBEST PRO		7m	21	HEAVY	N/A

● Domestic application ● Commercial application Light = Light commercial Heavy = Heavy commercial

TIPS

- Foreign objects such as pieces of cloth, dental floss, hygiene products, flushable wet wipes etc should not be flushed into the macerator.
- Macerators need minimum 4.5 L of unrestricted flush for optimal function.

APPLICATIONS



TOILET



HAND BASIN



WMTS 106:2019
Certificate No. 23048
Manufacturer: SFA
Brand: Saniflo

PRODUCT REFERENCE:
SA80

Product sheet
Instruction sheet



Saniaccess® 2

Designed to provide easy access for toilet with vanity applications. Convenient access panels allow one to service and maintain the macerator without having to remove it.



Double access:

- A Direct access to the blade if maintenance is required
- B Direct access to electric components



TECHNICAL CHARACTERISTICS

Discharge Pipework	20 mm
Motor Power	400 Watts
Voltages	220-240 V/50 Hz
Working Waste Water Temp	35°C
Product Weight	5.8 kg
Overall Measurements	490 x 330 x 168 mm
Inlet Pipework	40 mm
IP Rating	IP44

WHY CHOOSE THIS PRODUCT?

- Easy service access
- Suitable for one toilet and hand basin
- Easy maintenance without removal of unit
- Macerator needs minimum 4.5 L of unrestricted flush for optimal function
- Quiet technology
- Ideal for adding an additional toilet or powder room anywhere

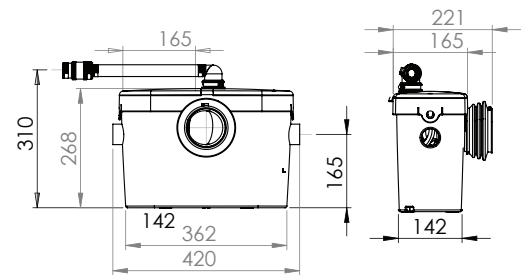

VERTICAL/HORIZONTAL PERFORMANCE

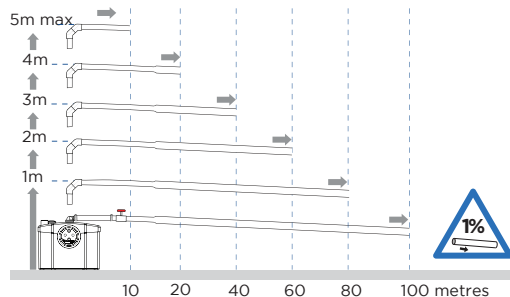

Increase size of horizontal run by one pipe size after 5m. All horizontal pipework requires a minimum of 1:100 fall.

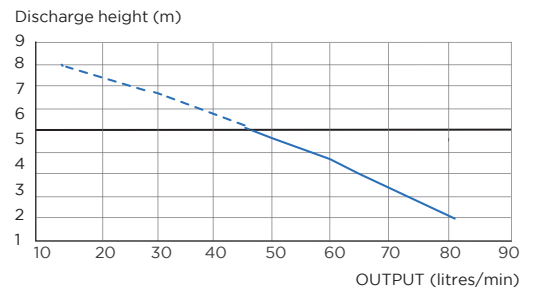

FLOW RATE PERFORMANCE CHART



Made in France to the highest standards, needs to be installed by a licensed plumber

Product sheet 
 Instruction sheet 



APPLICATIONS



TOILET



HAND BASIN



SHOWER

MACERATOR



WMTS 106:2019
 Certificate No. 23048
 Manufacturer: SFA
 Brand: Saniflo

PRODUCT REFERENCE:
 SA81

Saniaccess® 3

Designed to provide easy access for en-suite bathroom applications. Convenient access panels allow one to service and maintain the macerator without having to remove it.



TECHNICAL CHARACTERISTICS

Discharge Pipework	20 mm
Motor Power	400 Watts
Voltages	220-240 V/50 Hz
Working Waste Water Temp	35°C
Product Weight	6.4 kg
Overall Measurements	490 x 330 x 168 mm
Inlet Pipework	40 mm
IP Rating	IP44

WHY CHOOSE THIS PRODUCT?

- Easy service access
- Suitable for one toilet, basin and shower
- Easy maintenance without removal of unit
- Macerator needs minimum 4.5 L of unrestricted flush for optimal function
- Quiet technology
- Ideal for adding a complete bathroom or en-suite anywhere

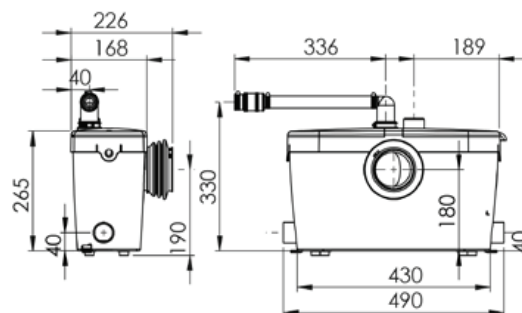

VERTICAL/HORIZONTAL PERFORMANCE

Increase size of horizontal run by one pipe size after 5m. All horizontal pipework requires a minimum of 1:100 fall.

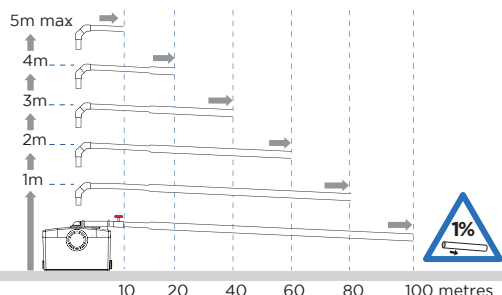

FLOW RATE PERFORMANCE CHART

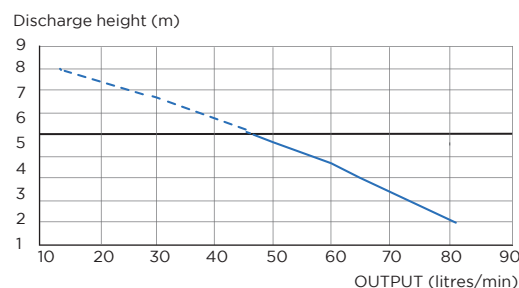

Double access:

A Direct access to the blade if maintenance is required

B Direct access to electric components

Made in France to the highest standards, needs to be installed by a licensed plumber

APPLICATIONS

WALL HUNG
TOILETHAND
BASIN



SHOWER



WMTS 106:2019
Certificate No. 23048
Manufacturer: SFA
Brand: Saniflo

PRODUCT REFERENCE:
SA99



Product sheet 
Instruction sheet 

Sanipack® Pro Up

Designed for discreet wall hung toilet installations, the Sanipack® Pro UP pumps waste from a toilet, basin and shower and has slim dimensions enabling possible concealment.



TECHNICAL CHARACTERISTICS

Discharge Pipework	20 mm
Motor Power	400 Watts
Voltages	220-240 V/50 Hz
Working Waste Water Temp	35°C
Product Weight	7 kg
Overall Measurements	472 x 303 x 169 mm
Inlet Pipework	40 mm
IP Rating	IP44

WHY CHOOSE THIS PRODUCT?

- Perfect for wall hung toilet suite
- Ideal solution for a complete en-suite
- Quiet technology
- Slim dimensions
- Access panels for ease of servicing
- Macerator needs minimum 4.5 L of unrestricted flush for optimal function

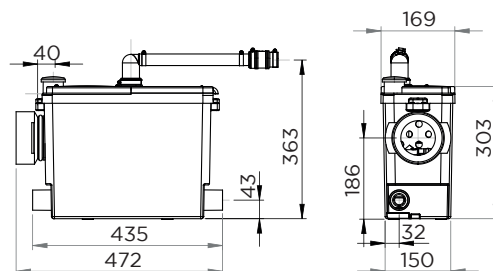

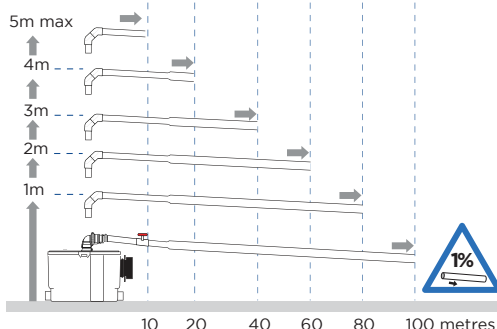

VERTICAL/HORIZONTAL PERFORMANCE

Increase size of horizontal run by one pipe size after 5m. All horizontal pipework requires a minimum of 1:100 fall.

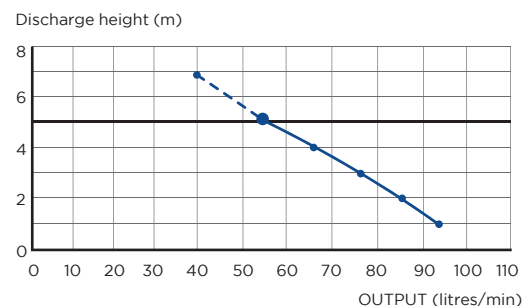

FLOW RATE PERFORMANCE CHART



Product sheet 
 Instruction sheet 



APPLICATIONS



TOILET



HAND
BASIN

MACERATOR



WMTS 106:2019
 Certificate No. 23048
 Manufacturer: SFA
 Brand: Saniflo

PRODUCT REFERENCE:
 SA97

Sanitop®

Sanitop® has a powerful macerator that makes it ideal for installing an additional toilet and hand basin where access to the main sewer is impractical.



TECHNICAL CHARACTERISTICS

Discharge Pipework	20 mm
Motor Power	400 Watts
Voltages	220-240 V/50 Hz
Working Waste Water Temp	35°C
Product Weight	5.8 kg
Overall Measurements	330 x 280 x 161 mm
Inlet Pipework	40 mm
IP Rating	IP44

WHY CHOOSE THIS PRODUCT?

- Can be equipped with Sanialarm (sold separately)
- Quiet technology
- Macerator needs minimum 4.5 L of unrestricted flush for optimal function

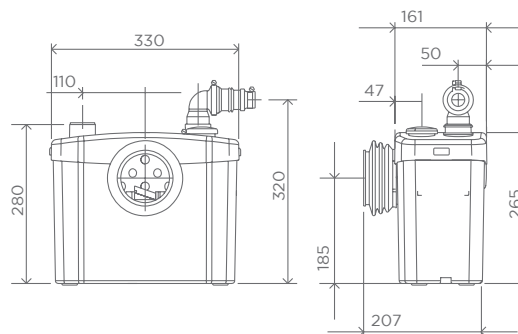

VERTICAL/HORIZONTAL PERFORMANCE

Increase size of horizontal run by one pipe size after 5m. All horizontal pipework requires a minimum of 1:100 fall.

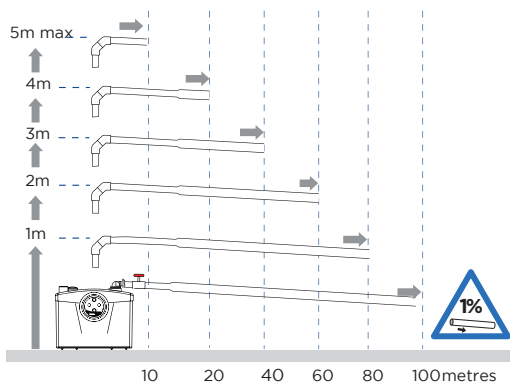

FLOW RATE PERFORMANCE CHART

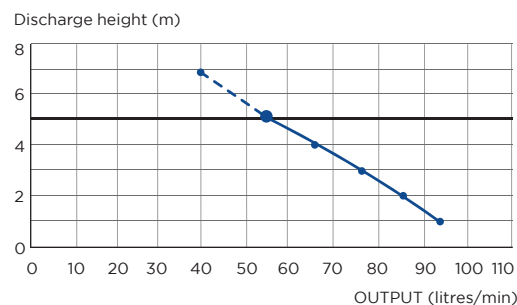

Made in France to the highest standards, needs to be installed by a licensed plumber

APPLICATIONS



TOILET



HAND BASIN



BATH



SHOWER



WMTS 106:2019
Certificate No. 23048
Manufacturer: SFA
Brand: Saniflo

PRODUCT REFERENCE:
SA98



Product sheet
Instruction sheet

Saniplus®

Saniplus® is a high capacity unit that will enable one to install a full bathroom. Its durable motor will enable long term and reliable running.



TECHNICAL CHARACTERISTICS

Discharge Pipework	20 mm
Motor Power	400 Watts
Voltages	220-240 V/50 Hz
Working Waste Water Temp	35°C
Product Weight	7.4 kg
Overall Measurements	510 x 263 x 178 mm
Inlet Pipework	40 mm
IP Rating	IP44

WHY CHOOSE THIS PRODUCT?

- Neat and functional design
- Can connect a toilet, basin, shower and bath tub
- Quiet technology
- Large tank capacity
- Macerator needs minimum 4.5 L of unrestricted flush for optimal function
- Can be equipped with Sanialarm (sold separately)

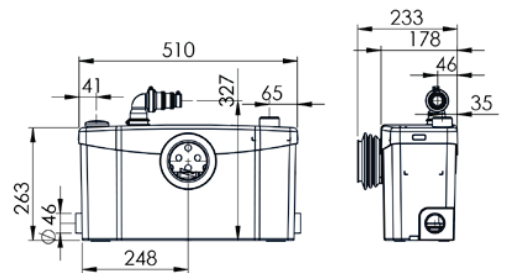

VERTICAL/HORIZONTAL PERFORMANCE

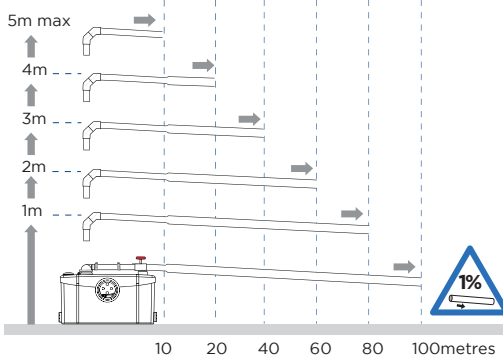

Increase size of horizontal run by one pipe size after 5m. All horizontal pipework requires a minimum of 1:100 fall.

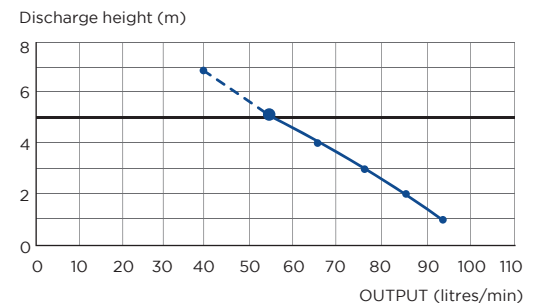

FLOW RATE PERFORMANCE CHART



Made in France to the highest standards, needs to be installed by a licensed plumber

Product sheet 
 Instruction sheet 



APPLICATIONS



TOILET



HAND
BASIN



SHOWER



WMTS 106:2019
 Certificate No. 23048
 Manufacturer: SFA
 Brand: Saniflo

PRODUCT REFERENCE:
 SA96

MACERATOR

Sanipro®

Sanipro® is the ideal option for installing
 a toilet, hand basin and shower.



TECHNICAL CHARACTERISTICS

Discharge Pipework	20 mm
Motor Power	400 Watts
Voltages	220-240 V/50 Hz
Working Waste Water Temp	35°C
Product Weight	6.4 kg
Overall Measurements	413 x 265 x 179 mm
Inlet Pipework	40 mm
IP Rating	IP44

WHY CHOOSE THIS PRODUCT?

- Compact neat and unobtrusive
- Capacity for en-suite installation
- Quiet technology
- Macerator needs minimum 4.5 L of unrestricted flush for optimal function
- Can be equipped with Sanialarm (sold separately)

VERTICAL/HORIZONTAL PERFORMANCE

Increase size of horizontal run by one pipe size after 5m.
 All horizontal pipework requires a minimum of 1:100 fall.

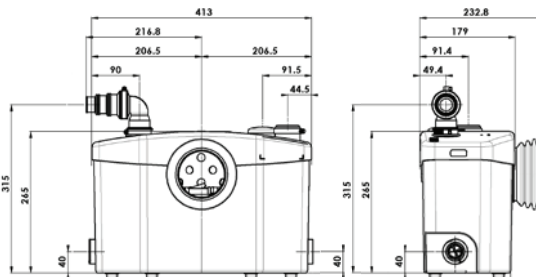
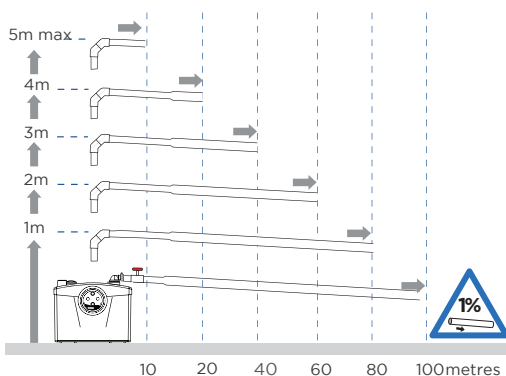

FLOW RATE PERFORMANCE CHART

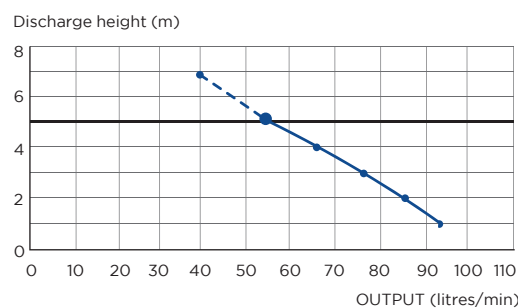

Made in France to the
 highest standards,
 needs to be installed
 by a licensed plumber

APPLICATIONS



TOILET



HAND BASIN



BATH



SHOWER



WMTS 106:2019
Certificate No. 23048
Manufacturer: SFA
Brand: Saniflo

PRODUCT REFERENCE:
SA100



Product sheet
Instruction sheet



Cover allows easy access to electronic components



Robust blade suitable for heavy usage

Made in France to the highest standards, needs to be installed by a licensed plumber

Sanibest® Pro

Sanibest® Pro is a heavy duty Macerator suitable for busy commercial environments.
Possible connection to a toilet, basin, bath and shower.



WHY CHOOSE THIS PRODUCT?

Ideal for heavy usage applications

Robust stainless steel macerator blade for intensive use

Macerator needs minimum 4.5 L of unrestricted flush for optimal function

Can be equipped with Sanialarm (sold separately)

TECHNICAL CHARACTERISTICS

Discharge Pipework	20 mm
Motor Power	1100 Watts
Voltages	220-240 V/50 Hz
Working Waste Water Temp	35°C
Product Weight	12 kg
Overall Measurements	507 x 285 x 204 mm
Inlet Pipework	40 mm
IP Rating	IP44

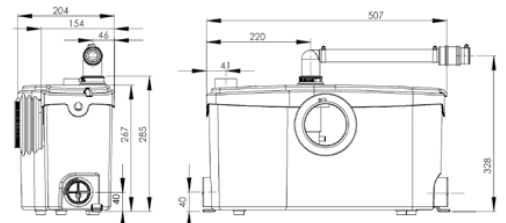

VERTICAL/HORIZONTAL PERFORMANCE

Increase size of horizontal run by one pipe size after 5m.
All horizontal pipework requires a minimum of 1:100 fall.

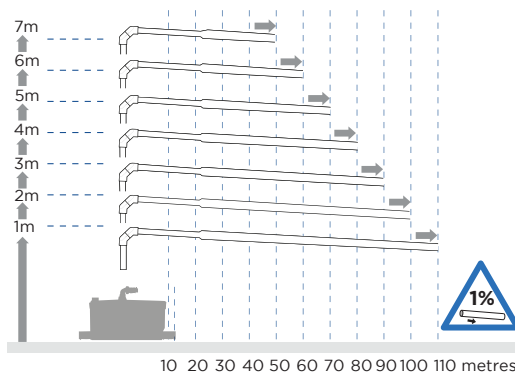

FLOW RATE PERFORMANCE CHART

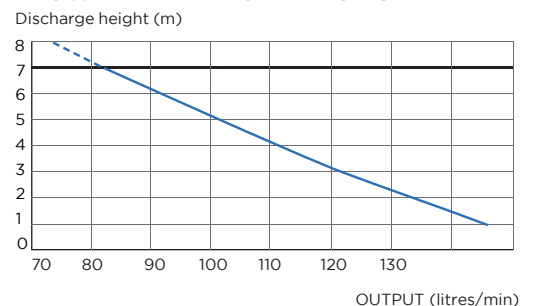



An empty office floor converted into **hospital accommodation**



Add an **additional toilet** anywhere



INTEGRATED MACERATOR

MODEL NO	PRODUCT NAME	POSSIBLE CONNECTIONS	PUMPING HEIGHT	PAGE	APPLICATION	
					COMMERCIAL	DOMESTIC
SA 106	SANICOMPACT		3m	26	N/A	

 Domestic application  Commercial application Light = Light commercial Heavy = Heavy commercial

TIPS

- To maintain optimum performance use Sanidescaler once every 6 months.

How does Sanicompact work?



Pushing the flush button allows water into the bowl

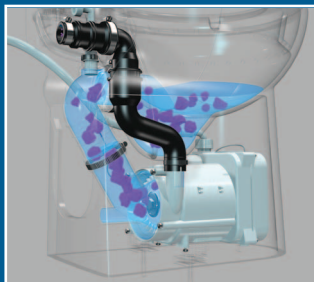

The waste is drawn into the macerator





The finely macerated waste is pumped out to the sewer via 25 mm pipe



Water is replenished in the bowl. It's ready to be used again



Product sheet 
 Instruction sheet 



APPLICATIONS



TOILET



HAND
BASIN



ATS 5200.101
 Certificate No. 23186
 Manufacturer: SFA
 Brand: Saniflo

PRODUCT REFERENCE:
 SA106

INTEGRATED MACERATOR

Sanicompact®

Sanicompact® is the first all in one macerating toilet suite. Adding a toilet is now as easy as one product. The compact design enables a toilet to be added where space is limited making Sanicompact® ideal for a powder room or laundry addition. It also features a water saving cistern-less flush and the ability to add a basin.

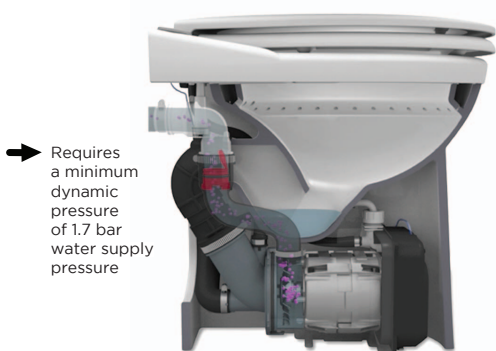

TECHNICAL CHARACTERISTICS

Discharge Pipework	25 mm
Motor Power	550 Watts
Voltages	220-240 V/50 Hz
Working Waste Water Temp	35°C
Product Weight	23.2 kg
Overall Measurements	440 x 462 x 388 mm
Dual flush	1.8 / 3 L
IP Rating	IP44

WHY CHOOSE THIS PRODUCT?

- A complete toilet suite with built in macerator
- Cistern-less flush button connected directly to the domestic water supply
- Features a soft-close toilet seat
- Water saving flush system
- Floor mounting kit
- Factory pre-mounted non return valve (supplied)

VERTICAL/HORIZONTAL PERFORMANCE

Increase size of horizontal run by one pipe size after 5m. All horizontal pipework requires a minimum of 1:100 fall.

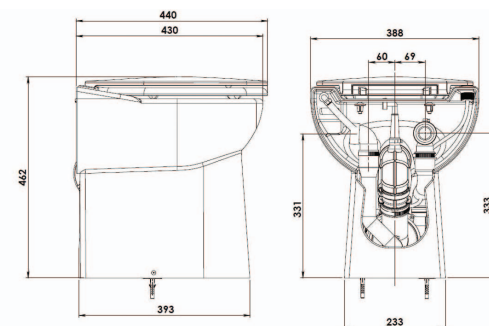
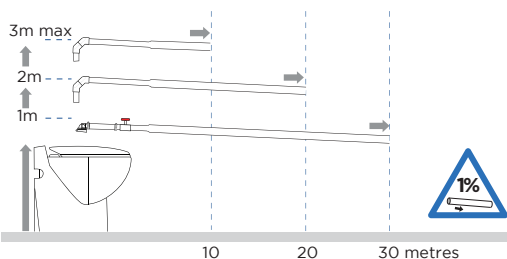

FLOW RATE PERFORMANCE CHART

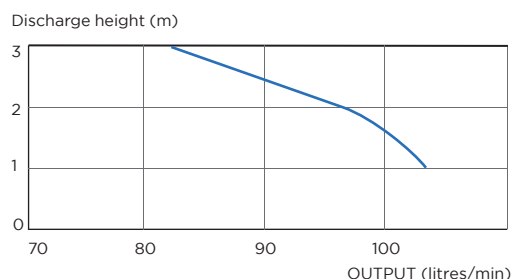

WATER RATING
www.waterrating.gov.au

2.2 litres
 average flush
 3 L per full flush / 1.8 L per half flush

In accordance with AS/NZS 6400
Licence No. 1507
 Saniflo

Made in France to the highest standards, needs to be installed by a licensed plumber

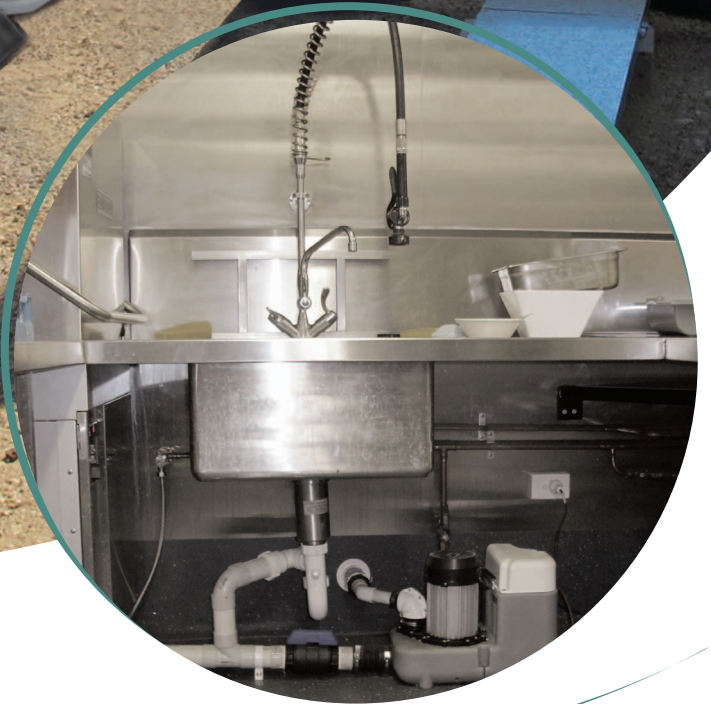

Container housing for **mining camp**



LIFTING STATION

MODEL NO	PRODUCT NAME	POSSIBLE CONNECTIONS	PUMPING HEIGHT	PAGE	APPLICATION	
					COMMERCIAL	DOMESTIC
SA 102	SANICOM 1		8m	29	HEAVY	N/A
SA 108	SANICOM 2		11m	30	HEAVY	N/A
SA 107	SANICUBIC 1 WP		11m	31	LIGHT ●	●
SA 104	SANICUBIC 2 PRO WP		11m	33	HEAVY	●
SA 111	SANICUBIC 2 VX SINGLE PHASE		10m	35	HEAVY	●
SA 300	SANICUBIC 1 GR		22m	37	HEAVY	●

● Domestic application ● Commercial application Light = Light commercial Heavy = Heavy commercial

TIPS

- Sanicom can handle a maximum of 90°C for a short period (5 minutes) and is recommended for commercial kitchens due to its high temperature and grease handling capabilities (programmed maintenance required).
- For heavier commercial kitchen use, we recommend Sanicom 2 which has two powerful motors and alternates duty cycle making it ideal for trading continuity.
- Sanicubic is the ideal combined black and grey water lifting station. Sanicubic 1 WP is applicable for granny flat extensions and light commercial environments.
- Sanicubic 2 Pro WP is suitable for a whole house or demanding commercial projects with twin heavy duty motors.
- Use Sanicubic 2 VX where uncontrolled usage could cause blockages.

APPLICATIONS



HAND
BASIN



BATH



SHOWER



WASHING
MACHINE



DISH
WASHER



KITCHEN
SINK



WMTS 106:2019
Certificate No. 23048
Manufacturer: SFA
Brand: Saniflo

PRODUCT REFERENCE:
SA102

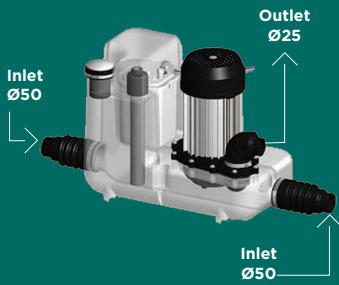

Product sheet

Instruction sheet

Sanicom®1

Sanicom®1 is a powerful lifting station for grey water in busy commercial environments. Suitable for multiple connections including a basin, bath, shower, sink, dishwasher and washing machine.



WHY CHOOSE THIS PRODUCT?

Ideal for commercial applications e.g. cleaning/ catering sinks

Heavy duty, safe, reliable pump

Unit operates automatically

Two 50 mm side entries and air vent/connection to exterior

Working temperature of 35°C

Will handle up to 90°C for short periods (5 minutes)

TECHNICAL CHARACTERISTICS

Discharge Pipework	25 mm
Motor Power	750 Watts
Voltages	220-240 V/50 Hz
Tank Volume	10 L
Working Waste Water Temp	35°C/Max 90°C (intermittent)
Product Weight	12 kg
Overall Measurements	490 x 330 x 230 mm
Inlet Pipework	50 - 65 mm
IP Rating	IP44

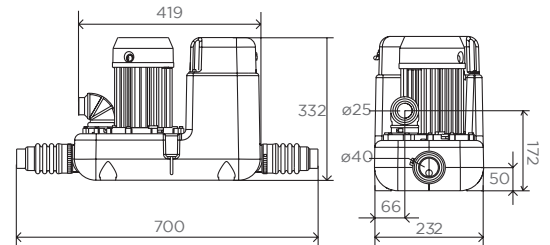

VERTICAL/HORIZONTAL PERFORMANCE

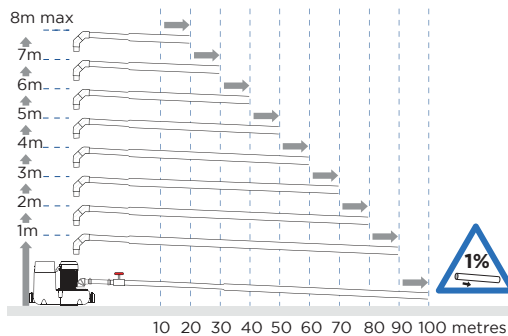

Increase size of horizontal run by one pipe size after 5m.
All horizontal pipework requires a minimum of 1:100 fall.

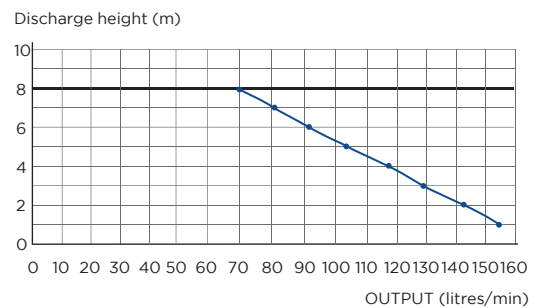

FLOW RATE PERFORMANCE CHART



Made in France to the highest standards, needs to be installed by a licensed plumber

Product sheet 
 Instruction sheet 



Sanicom® 2

Sanicom® 2 is a commercial grey water lifting station featuring two powerful motors, ensuring continuity of service for your business.

WHY CHOOSE THIS PRODUCT?

Ideal for heavy commercial applications

Safe, reliable twin motor pump for continuity of service

Unit operates automatically

1/65 mm rear and two 80 mm side entries and air vent connection for external venting

Working temperature of 35°C

Will handle up to 90°C for short periods (5 minutes)

External hard-wired alarm

Alternates duty cycle

2 x pre mounted non return valves (supplied)

2 m pre wired cable



VERTICAL/HORIZONTAL PERFORMANCE

Increase size of horizontal run by one pipe size after 5m. All horizontal pipework requires a minimum of 1:100 fall.

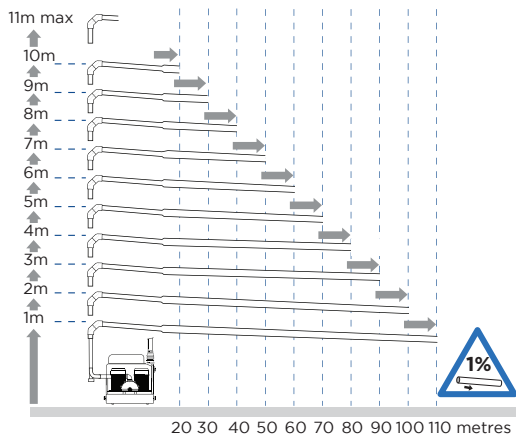

TECHNICAL CHARACTERISTICS

Discharge Pipework	40/50 mm
Motor Power	1500 Watts x 2
Voltages	220-240 V/50 Hz
Tank Volume	34.5 L
Working Waste Water Temp	35°C/Max 90°C (intermittent)
Product Weight	26 kg
Overall Measurements	582 x 486 x 529 mm
Inlet Pipework	50/65/80 mm
IP Rating	IP44

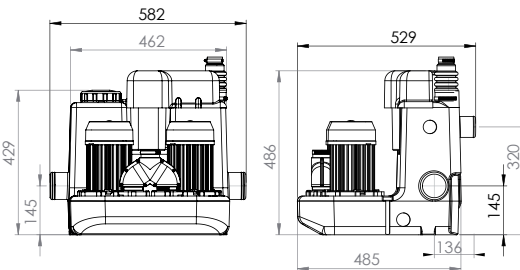

FLOW RATE PERFORMANCE CHART

Discharge height (m)

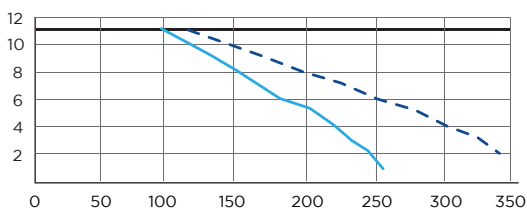

P1 - Output flow rate with one motor engaged
 P1 + P2 - Output flow rate with two motors engaged (litres/min)

APPLICATIONS



HAND BASIN



BATH



SHOWER



WASHING MACHINE



DISH WASHER



KITCHEN SINK



WMTS 106:2019
 Certificate No. 23048
 Manufacturer: SFA
 Brand: Saniflo

PRODUCT REFERENCE:
 SA108



Wired alarm panel (optional)



External mounted control box

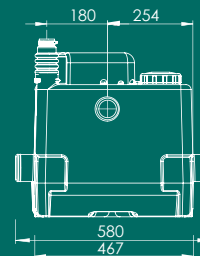

Made in France to the highest standards, needs to be installed by a licensed plumber

APPLICATIONS



TOILET



HAND BASIN



BATH



SHOWER



WASHING MACHINE



DISH WASHER



KITCHEN SINK



WMTS 106:2019
Certificate No. 23048
Manufacturer: SFA
Brand: Saniflo

Product Reference:
SA107

Made in France to the highest standards, needs to be installed by a licensed plumber

Product sheet



Instruction sheet



Sanicubic® 1 WP

Sanicubic® 1 WP is ideal for use in a granny flat addition as it can remove waste water from multiple fixtures. It features a powerful 1500W motor, high flow rate performance, and an IP68 waterproof rating.



Note: Isolation valves should be fitted to the inlet pipework and discharge pipework to isolate the unit for servicing.

WHY CHOOSE THIS PRODUCT?

Ideal for additional granny flats and studios

Tough, reliable macerating lifting station

New design with easily removable motor for servicing and maintenance

External hard wired audio visual alarm

Features integrated non-return valves

Centre heights of inlets 140 mm

Working temperature of 35°C. Will handle up to 70°C for short periods (5 minutes)

IP68 rated

Base of pump needs to be minimum 275 mm below lowest fixture

Allow 200 mm clearance around pump for maintenance purposes

VERTICAL/HORIZONTAL PERFORMANCE

Increase size of horizontal run by one pipe size after 5m. All horizontal pipework requires a minimum of 1:100 fall.

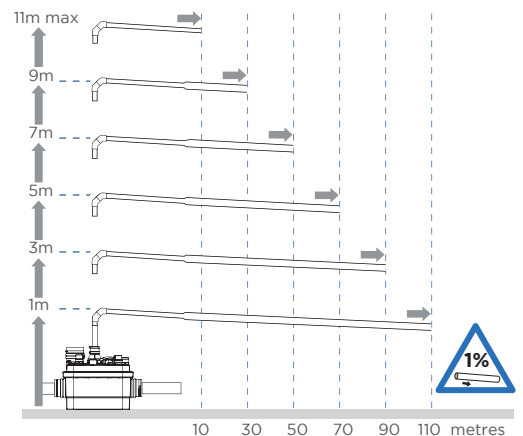

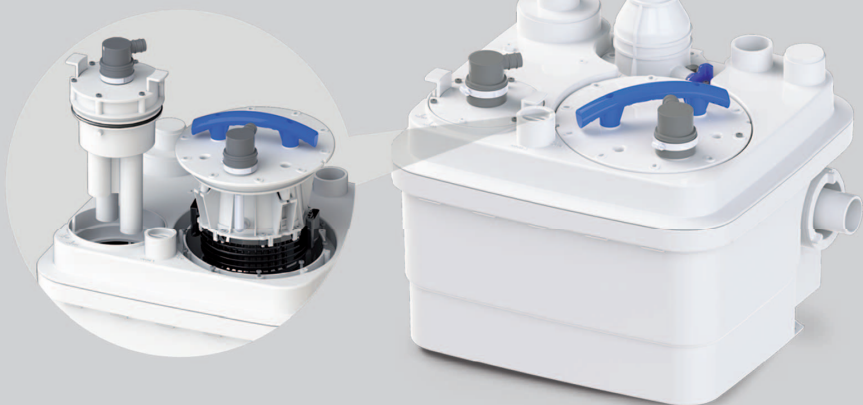

APPLICATIONS



TOILET



HAND BASIN



BATH



SHOWER



WASHING MACHINE



DISH WASHER



KITCHEN SINK



WMTS 106:2019
Certificate No. 23048
Manufacturer: SFA
Brand: Saniflo

PRODUCT REFERENCE:
SA107



Remote hard wired alarm panel



External mounted control box



Robust blade suitable for heavy usage

Made in France to the highest standards, needs to be installed by a licensed plumber

TECHNICAL CHARACTERISTICS

Discharge Pipework	40 mm
Motor Power	1500 Watts
Flow Rate	13 m ³ /h
Voltages	220-240 V/50 Hz
Tank Volume	32 L
Working Waste Water Temp	35°C/Max 70°C (intermittent)
Product Weight	20 kg
Overall Measurements	570 x 439 x 426 mm
Inlet Pipework	40/50/100/110 mm
IP Rating	IP68
Cable length for Control Panel	4m
Cable length for Wired Alarm Panel	5m

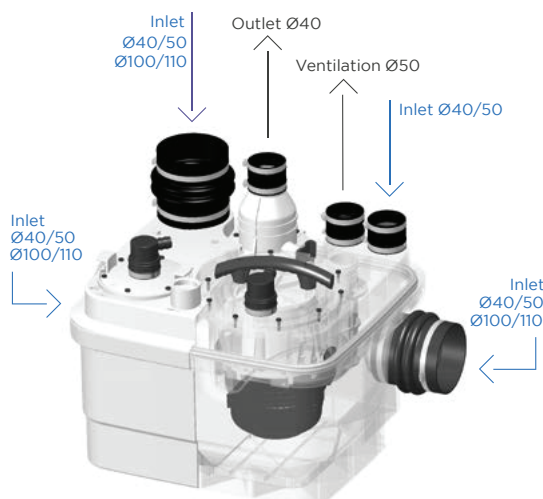
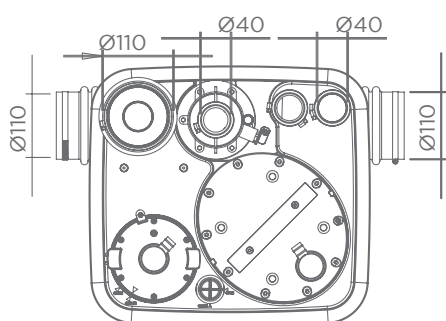
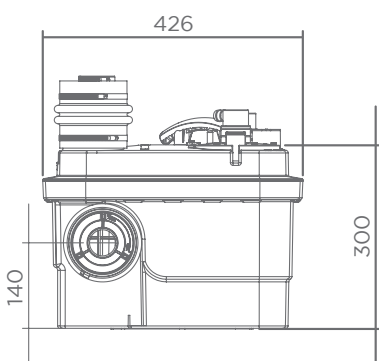
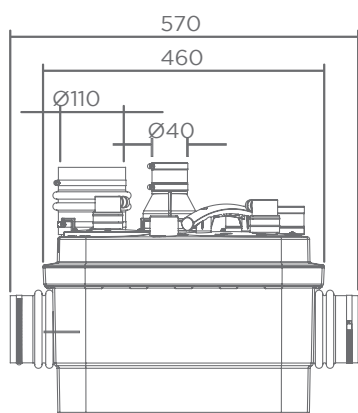

FLOW RATE PERFORMANCE CHART

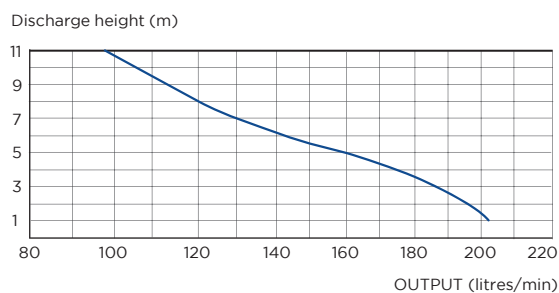

APPLICATIONS



TOILET



HAND BASIN



BATH



SHOWER



WASHING MACHINE



DISH WASHER



KITCHEN SINK



WMTS 106:2019
Certificate No. 23048
Manufacturer: SFA
Brand: Saniflo

Product Reference:
SA104

Made in France to the highest standards, needs to be installed by a licensed plumber



Product sheet



Instruction sheet



Sanicubic® 2 Pro WP

The Sanicubic® 2 Pro WP is a high performance macerating lifting station for commercial and intensive residential use. Twin motor load balanced system utilising high performance stainless steel cutter technology and IP68 submersible rating.



Note: Isolation valves should be fitted to the inlet pipework and discharge pipework to isolate the unit for servicing.

WHY CHOOSE THIS PRODUCT?

Ideal for busy business environments and larger domestic situations

Tough, reliable macerator pump

New design with easily removable motor for servicing and maintenance

Load balanced twin macerator pumps for a failsafe system

Alternate activation ensures even wear of motors

Two alarms for ultimate safety - hard-wired alarm plus remote wireless alarm

Centre heights of inlets 140 mm

Working temperature of 35°C. Will handle up to 70°C for short periods.

IP68 rated

Can be connected to a Building Management System

Base of pump needs to be minimum 275 mm below lowest fixture

Allow 200 mm clearance around pump for maintenance purposes

VERTICAL/HORIZONTAL PERFORMANCE

Increase size of horizontal run by one pipe size after 5m. All horizontal pipework requires a minimum of 1:100 fall.

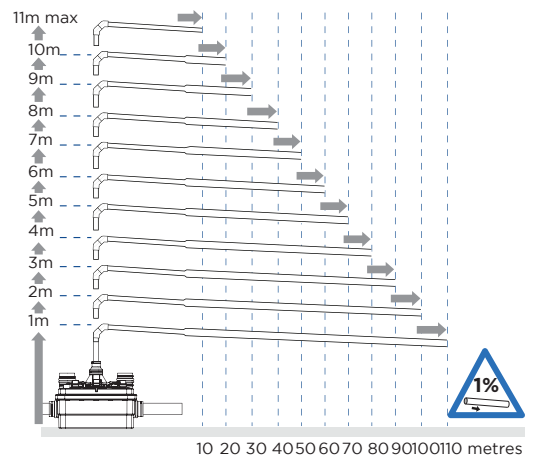

10 20 30 40 50 60 70 80 90 100 110 metres



APPLICATIONS



TOILET



HAND BASIN



BATH



SHOWER



WASHING MACHINE



DISH WASHER



KITCHEN SINK

LIFTING STATION

TECHNICAL CHARACTERISTICS

Discharge Pipework	40 mm
Motor Power	1500 Watts x 2
Flow Rate	13 m ³ /h
Voltages	220-240 V/50 Hz
Tank Volume	45 L
Working Waste Water Temp	35°C/Max 70°C (intermittent)
Product Weight	33 kg
Overall Measurements	597 x 495 x 517 mm
Inlet Pipework	40/50/100/110 mm
IP Rating	IP68
Cable length for Control Panel	4m
Cable length for Wired Alarm Panel	5m

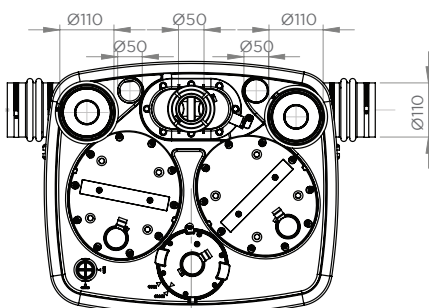
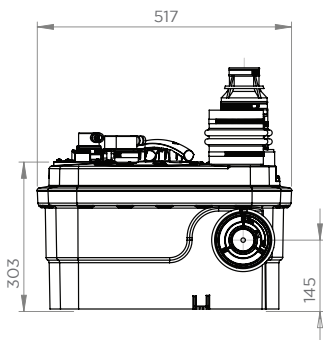
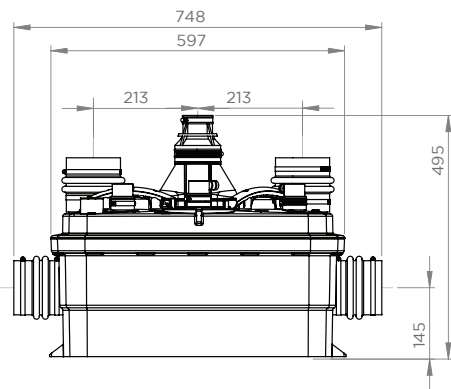

Externally mounted control box

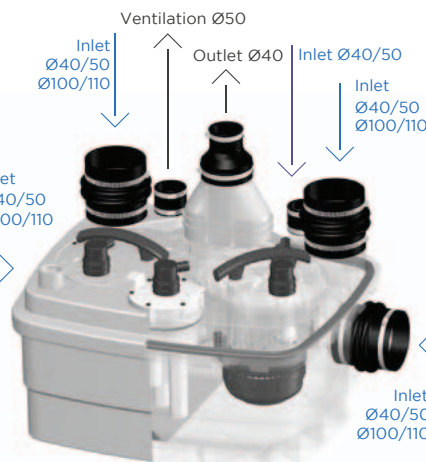
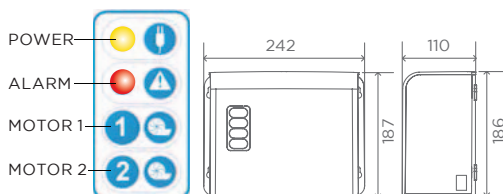

FLOW RATE PERFORMANCE CHART

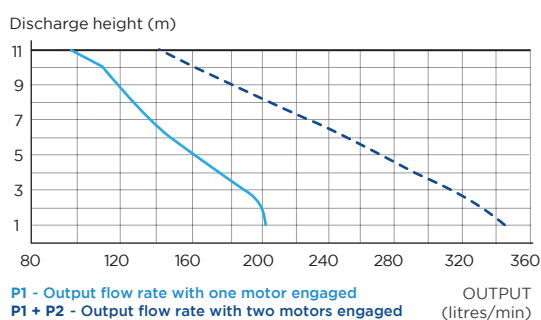

WMTS 106:2019
Certificate No. 23048
Manufacturer: SFA
Brand: Saniflo

PRODUCT REFERENCE:
SA104



ALARM SIGNAL INDICATOR

Remote wireless alarm



External mounted control box



Robust blade suitable for heavy usage

Made in France to the highest standards, needs to be installed by a licensed plumber

APPLICATIONS



TOILET



HAND BASIN



BATH



SHOWER



WASHING MACHINE



DISH WASHER



KITCHEN SINK



WMTS 106:2019
Certificate No. 23048
Manufacturer: SFA
Brand: Saniflo

PRODUCT REFERENCE:
SA111

Made in France to the highest standards, needs to be installed by a licensed plumber

Product sheet
Instruction sheet

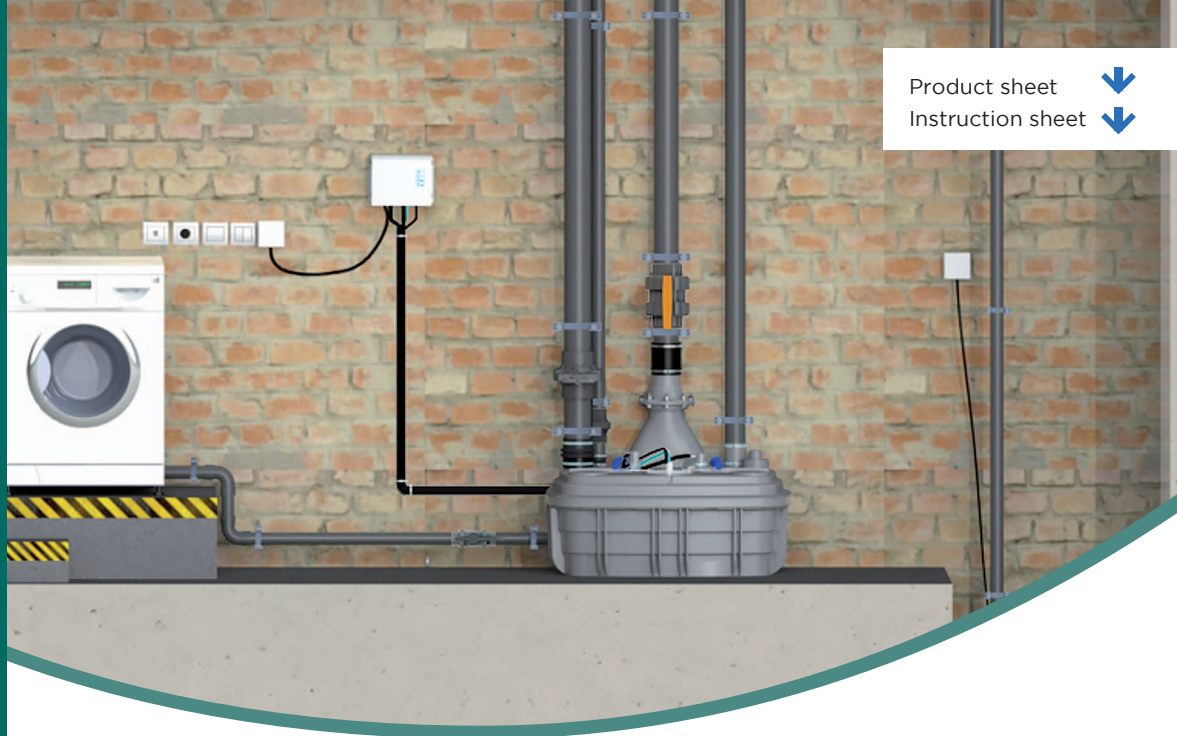

Sanicubic® 2 VX

SINGLE PHASE

Sanicubic® 2 VX is a powerful lifting station used for demanding commercial situations. It features twin 2000w motors, vortex blade-less pumping technology which is well suited for applications to eliminate blockages.

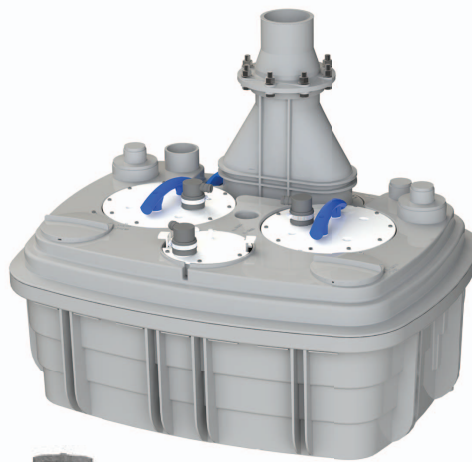

Note: Isolation valves should be fitted to the inlet pipework and discharge pipework to isolate the unit for servicing.

WHY CHOOSE THIS PRODUCT?

Ideal for large volume commercial situations.

Large bore vortex pump with a 50 mm free passage capable of pumping waste water without the need to macerate.

Easily removable motors for servicing and maintenance.

Large 120 L tank volume.

Easy to install - no need to excavate.

Two alarms for ultimate safety - both hard-wired.

Two integrated non-return valves and four inlets: 40/50/100/110 mm and one inlet 40/50 mm.

Working temperature of 35°C. Will handle up to 70°C for short periods.

Volt free contact for connection to a Building Management System

Control panel has built in alarm, with an additional wired alarm.

Control panel mounted up to 4 m from pump and additional alarm can be mounted up to 5 m from control panel.

Base of pump needs to be minimum 275 mm below lowest fixture

Allow 200 mm clearance around pump for maintenance purposes

VERTICAL/HORIZONTAL PERFORMANCE

Increase size of horizontal run by one pipe size after 5m. All horizontal pipework requires a minimum of 1:100 fall.

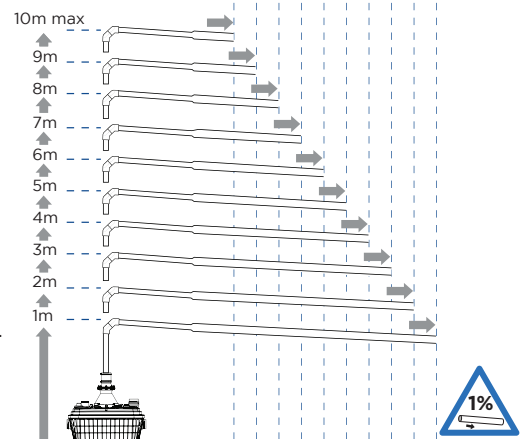

10 20 30 40 50 60 70 80 90 100 metres



APPLICATIONS



TOILET



HAND BASIN



BATH



SHOWER



WASHING MACHINE



DISH WASHER



KITCHEN SINK

LIFTING STATION

TECHNICAL CHARACTERISTICS

Discharge Pipework	80 mm pipework. Maximum vertical lift 10 m. 100 mm pipework maximum vertical lift 6 m.
Motor Power	2000 Watts x 2
Flow Rate	40 m ³ /h
Voltages	220-240 V/50 Hz
Tank Volume	120 L
Working Waste Water Temp	35°C/Max 70°C (intermittent)
Product Weight	59 kg
Overall Measurements	952 x 751 x 713 mm
IP Rating	IP68
Cable length for Control Panel	4m
Cable length for Wired Alarm Panel	5m

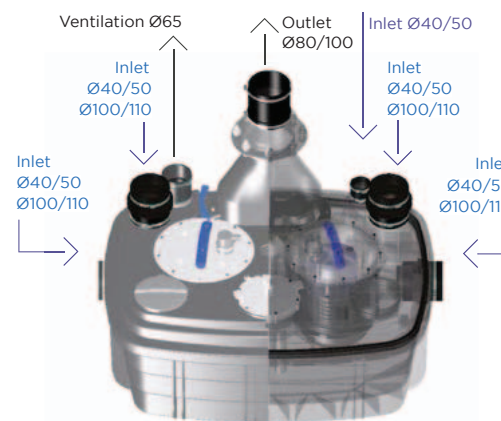
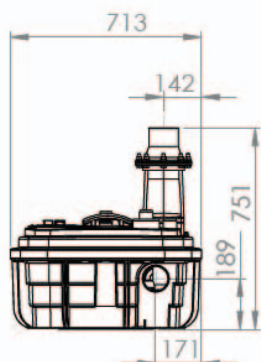
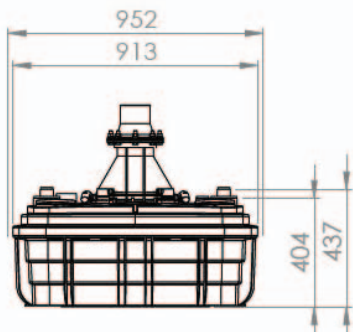
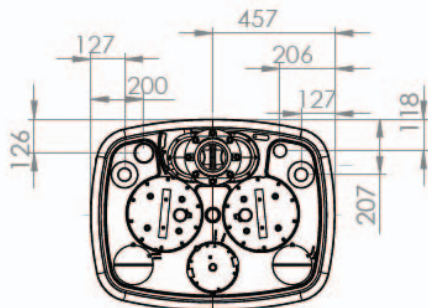

PRODUCT REFERENCE: SA111



Wired alarm



External mounted control box

FLOW RATE PERFORMANCE CHART

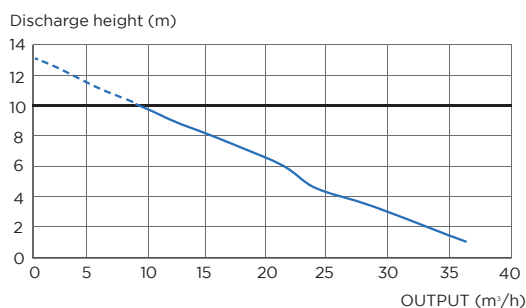

Externally mounted control box

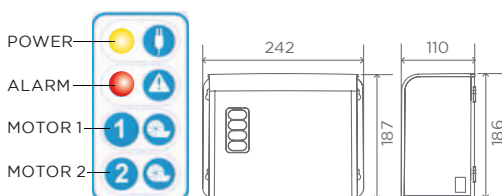

Made in France to the highest standards, needs to be installed by a licensed plumber

APPLICATIONS



TOILET

HAND
BASIN

BATH



SHOWER

WASHING
MACHINEDISH
WASHERKITCHEN
SINK

WMTS 106:2019
Certificate No. 23048
Manufacturer: SFA
Brand: Saniflo

PRODUCT REFERENCE:
SA300

Made in France to the
highest standards,
needs to be installed
by a licensed plumber

Product sheet

Instruction sheet



Sanicubic® 1 GR

Sanicubic® 1 GR is ideal for sloping waterfront properties where a boathouse could be converted to run amenities or rural properties where main drainage is too far away. It features a powerful 2200W motor, high flow rate performance, and an IP68 waterproof rating.

WHY CHOOSE THIS PRODUCT?

- Compact dimensions
- Tough, reliable macerating lifting station
- Intelligent level controller
- External hard wired audio visual alarm
- Features integrated non-return valves
- Will handle up to 55°C intermittent
- IP68 rated

VERTICAL/HORIZONTAL PERFORMANCE

Increase size of horizontal run by one pipe size after 5m. All horizontal pipework requires a minimum of 1:100 fall.

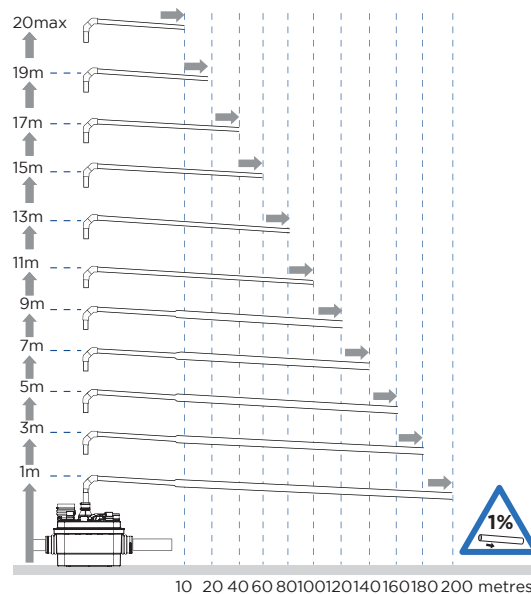

TECHNICAL CHARACTERISTICS

Discharge Pipework	40 mm
Motor Power	2200 Watts
Flow Rate	17 m ³ /h
Voltages	220-240 V/50 Hz
Tank Volume	55 L
Working Waste Water Temp	55°C Max (intermittent)
Product Weight	64 kg
Overall Measurements	570 x 439 x 460 mm
Inlet Pipework	50/100 mm
IP Rating	IP68

FLOW RATE PERFORMANCE CHART

Discharge height (m)

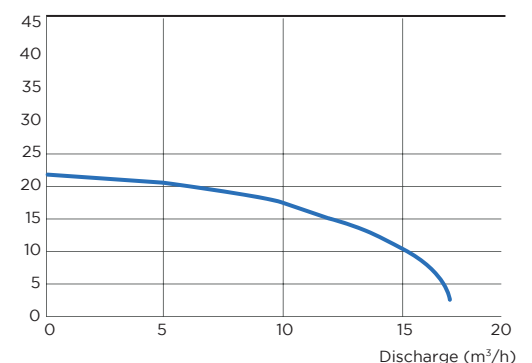



APPLICATIONS



TOILET

HAND BASIN



BATH

SHOWER



WASHING MACHINE

DISH WASHER



KITCHEN SINK

The controller system is operated via program settings which are displayed on the LCD screen. All settings are saved so that they are available when the control system is restarted. The display language can be changed. Besides the actual operational parameters, the controller system also saves the controlling process and records any irregularities which can be displayed on the LCD screen.



WMTS 106:2019
Certificate No. 23048
Manufacturer: SFA
Brand: Saniflo

PRODUCT REFERENCE:
SA300

CONTROLLER CHARACTERISTICS

Clear LCD display

Internal acoustic alarm

Programmable operation and fault signal

Maintenance interval counter

Recording of the fault protocol

Electronic monitoring of the motor current

Internal pressure sensor

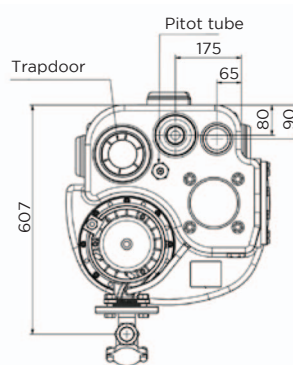
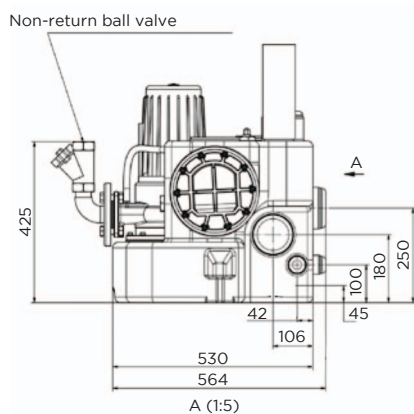

Flexible connection piece DN 65 for vent pipe

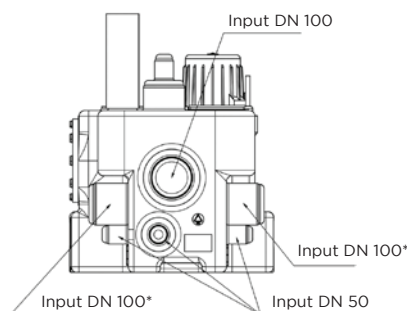
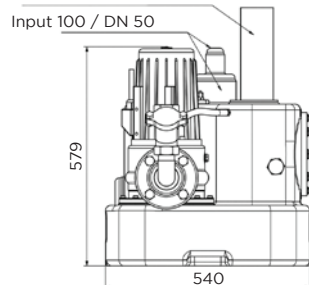

*This entrance must be directed at a height of 250 mm above the ground level directly after the lifting station.



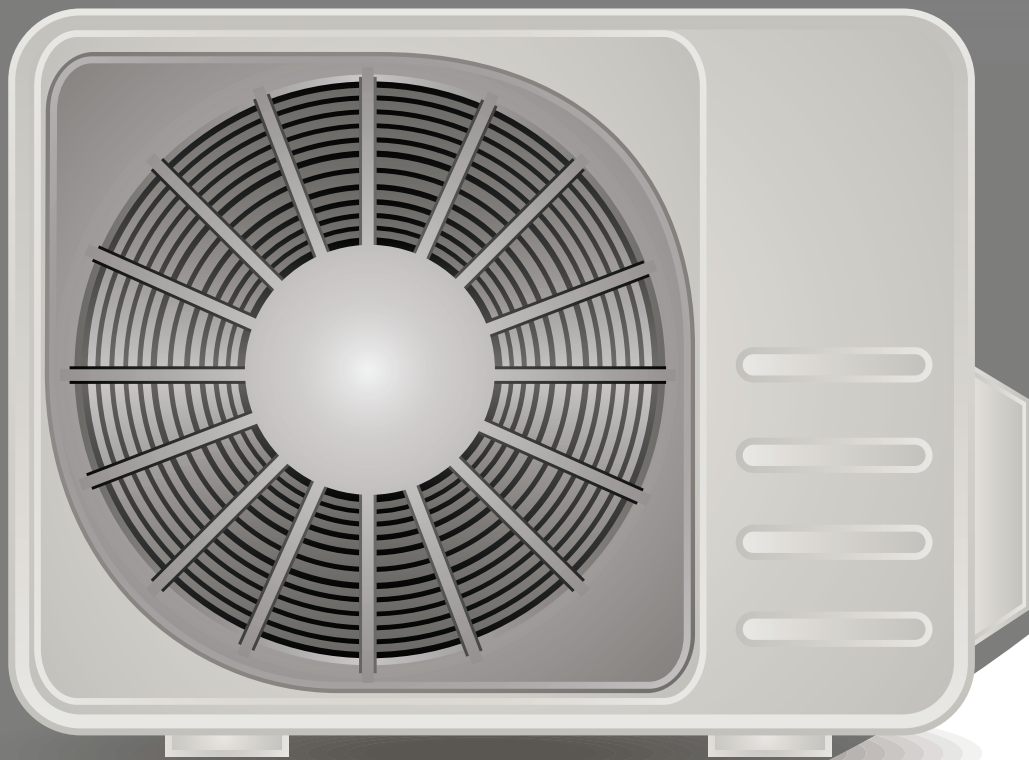



Made in France to the highest standards, needs to be installed by a licensed plumber



Air conditioners produce condensate which needs to be removed by a pump

CONDENSATE



MODEL NO	PRODUCT NAME	POSSIBLE CONNECTIONS	PUMPING HEIGHT	PAGE	APPLICATION	
					COMMERCIAL	DOMESTIC
SA92	SANICONDENS PRO	 	4.5m	41	✓	✓
SA110	SANICONDENS CLIM MINI S		6m	42	✓	✓
SA91	SANICONDENS BEST FLAT	  	4.5m	43	✓	✓

APPLICATIONS





REFRIGERATOR



AIRCONDITIONER

PRODUCT REFERENCE:
SA92

Product sheet 
Instruction sheet 



Sanicondens® Pro

The Sanicondens® Pro is specifically designed for disposal of condensate from air conditioning units, refrigeration units, ice machines and dehumidifiers etc. Includes a non-return valve and 6 m flexible discharge pipe.



TECHNICAL CHARACTERISTICS

Discharge Pipework	8/11 mm
Motor Power	60 Watts
Flow Rate	342 L/h
Voltages	220-240 V/50 Hz
Tank Volume	2 L
Working Waste Water Temp	35°C/Max 80°C (intermittent)
Product Weight	2 kg
Overall Measurements	260 x 169 x 143 mm
Inlet Pipework	25 mm
IP Rating	IP20

WHY CHOOSE THIS PRODUCT?

2 L tank

Two entry points

Working temperature of 35°C.

Will handle temperatures up to 80°C for short periods (5 minutes)

Supplied with 2 m of electric cable and 6 m of discharge pipe

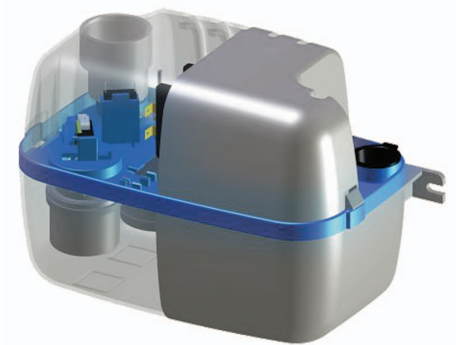

High level alarm connectivity

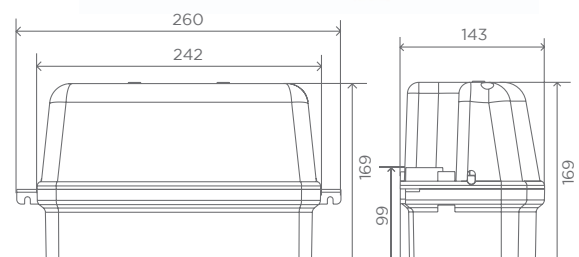

VERTICAL/HORIZONTAL PERFORMANCE



Made in France to the highest standards, needs to be installed by a licensed plumber

Product sheet 
 Instruction sheet 



Sanicondens® Clim Mini S

The new scaled down generation of pump for wall air conditioners, designed to meet market requirements and is now equipped with the best features.

APPLICATIONS



AIRCONDITIONER

PRODUCT REFERENCE:
SA110

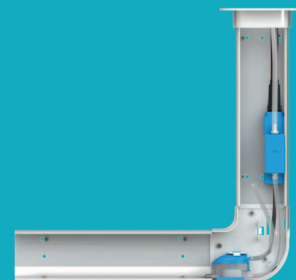

Sanicondens Clim Mini S pack includes a fixing plate

CONDENSATE



TECHNICAL CHARACTERISTICS

Low Noise Level	21 dB(A)
Possible Connections	Air conditioners up to 8kW / 27 000 BTU
Ø int. Inlet	16 mm
Ø int. Discharge Pipework	6 mm
Maximum Fflow	9 l/h +/- 15%
Maximum Incoming Water Temperature	35 °C
Maximum Suction Lift (between the detection unit and the pump)	2 m
Voltage	220-240 V
Supply Frequency	50 Hz
Max Power	22 W
IP Rating Index	IP20

WHY CHOOSE THIS PRODUCT?

Designed for air conditioner split systems

Very quiet operation

A compact pump for hidden installation inside head unit

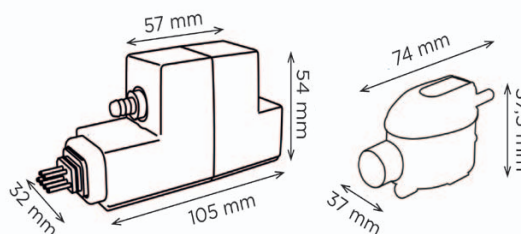

FLOW RATE PERFORMANCE CHART

Discharge height (m)

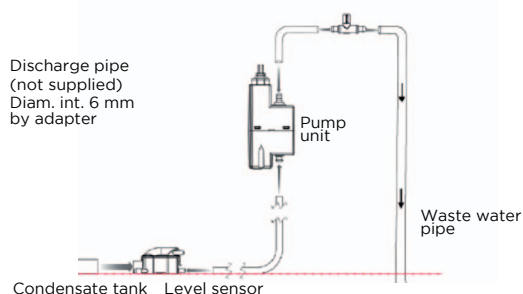
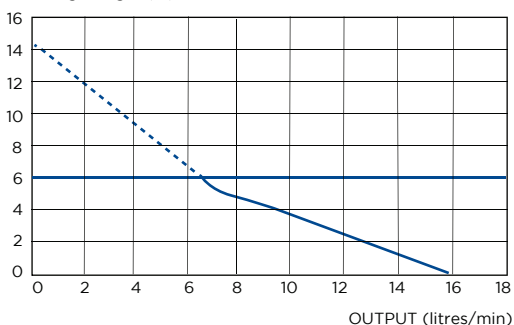

Made in France to the highest standards, needs to be installed by a licensed plumber

APPLICATIONS



REFRIGERATOR



AIRCONDITIONER



ICE MACHINE

PRODUCT REFERENCE:
SA91Product sheet
Instruction sheet 

Sanicondens® Best Flat

The Sanicondens® Best Flat is specifically designed for disposal of condensate from air conditioning units, refrigeration units and is ideal for ice machines due to its low profile design.

TECHNICAL CHARACTERISTICS

Noise Level	45 dB
Motor Power	60 Watts
Flow Rate	342 L/h
Voltages	220-240 V/50 Hz
Tank Volume	3.5 L
Working Waste Water Temp	35°C/Max 80°C (intermittent)
Product Weight	2 kg
Overall Measurements	260 x 169 x 143 mm
Inlet Pipework	25/32 mm
IP Rating	IP20



WHY CHOOSE THIS PRODUCT?

3.5 L tank

Three entry points

Working temperature of 35°C

Will handle temperatures up to 80°C for short periods (5 minutes)

Supplied with 1.5 m power cable and 5m of discharge pipe

High level alarm connectivity

Low profile inlet connection

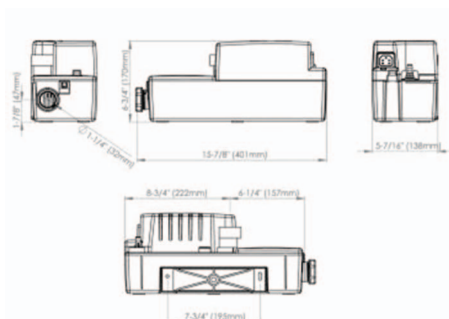

VERTICAL/HORIZONTAL PERFORMANCE



Made in France to the highest standards, needs to be installed by a licensed plumber

FLOW RATE PERFORMANCE CHART

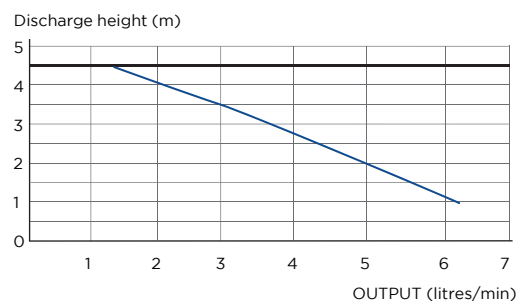

ADDITIONAL PRODUCTS





MODEL NO	PRODUCT NAME	POSSIBLE CONNECTIONS	PAGE	APPLICATION	
				COMMERCIAL	DOMESTIC
ALARM 1	SANIALARM		47	✓	✓
SANI12661	SANIALARM INTERLOCK		48	✓	✓
DETAUST	SANIDESCALER		49	✓	✓
DN100	SANIKNIFE VALVE		49	✓	✓

TIPS

- Test your batteries once a year in Sanialarm.
- Use 2.5 litres of descaler twice yearly. To do this turn the power off to the Macerator, pour 2.5 litres in the pan let sit for 3 hours then turn the power back on to clean, flush 3-4 times.
- We recommend using a knife valve to isolate the incoming waste line to accommodate servicing.

PRODUCT REFERENCE:
ALARM1

Product sheet 
Instruction sheet 



Sanialarm®

The Sanialarm® has a level pressure switch that triggers an alarm if the volume of water exceeds the maximum allowed level. The alarm emits a continuous warning sound until it is switched off and the problem rectified.

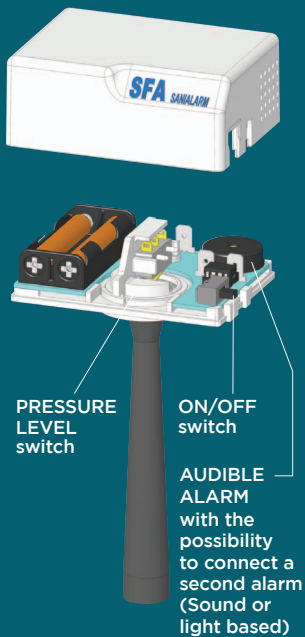

TECHNICAL CHARACTERISTICS

Power	2 x AAA batteries - 1.5v (not included)
Weight	0.17 kg

STEP BY STEP INSTALLATION

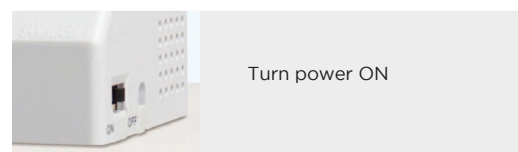
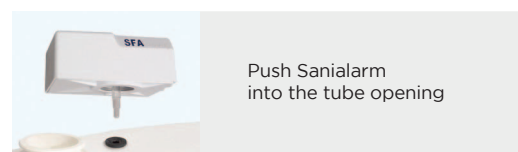
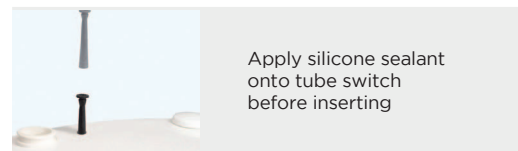
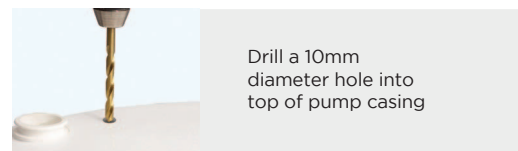
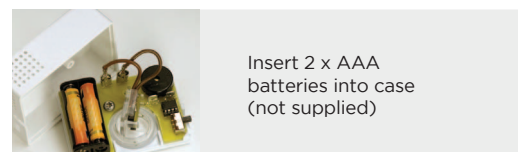

WHY CHOOSE THIS PRODUCT?

- Helps protect against flooding
- 80dB buzzer
- Added peace of mind
- Easy and quick installation onto lid of Saniflo unit
- Suitable for new and existing Saniflo installations
- Fits most Saniflo products - see product selector for details

Made in France to the highest standards, needs to be installed by a licensed plumber



Sanialarm® Interlock

The Sanialarm Interlock has 3 functions, whereby it sets off an audible alarm in the event of a high level issue and simultaneously shuts off incoming water supply to prevent flooding whilst cutting the power supply to the dishwasher or washing machine.



WHY CHOOSE THIS PRODUCT?

- Helps protect against flooding
- Audible and visual alarm
- Power interlock for dishwasher or washing machine
- Easy and quick plug and play installation, no electrician required
- Suitable for new and existing Saniflo installations
- Kit comes complete with magnetic float switch and low voltage solenoid with pre wired plugs

TECHNICAL CHARACTERISTICS

Voltage	220-240 V/50 Hz
Power consumption	5 Watts
Alarm	80dB

BMS (Building Management System) connective

NOTE: Warranty only applies when the Sanialarm Interlock is used with Saniflo SFA products.

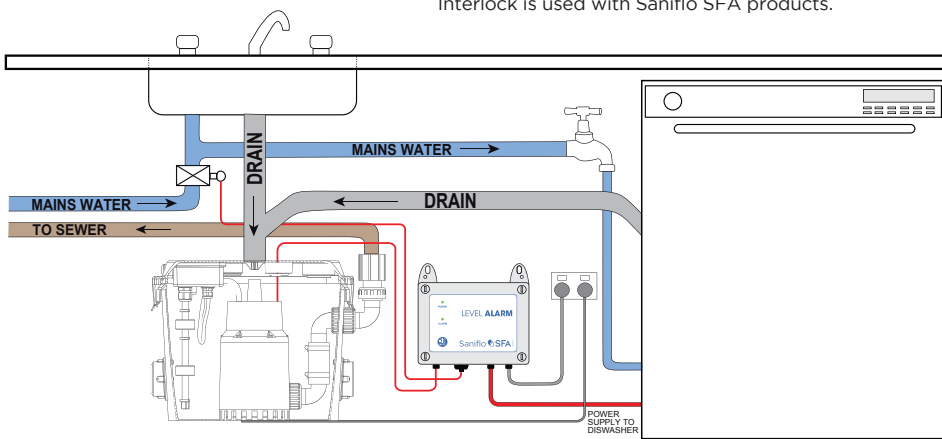

This product is Made in Australia to the highest standards, needs to be installed by a licensed plumber

APPLICATIONS



TOILET

PRODUCT REFERENCE:
DETAUST



Product sheet

Instruction sheet

Sanidescaler®

A powerful cleaning agent specially formulated for use with Saniflo products. The concentrated formula is essential for maintaining the efficiency of the pump's internal operation. Periodic use will ensure any waste build up is removed and bad odours are minimised.

*Compatible with septic tank use.



Saniknife Valve®

Installing a knife valve is essential for any commercial pump application. It should always be installed on the line coming into the inlets of the pump, so if maintenance is required, the pump can be isolated quickly and easily.

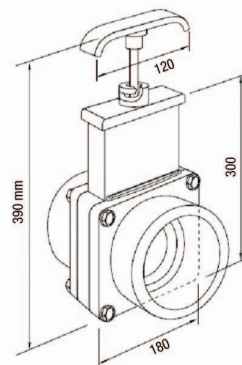

Made in France to the highest standards, needs to be installed by a licensed plumber

INSTALLATION GUIDE

10 golden rules for correct installation

Detailed installation instructions accompany every product. Please provide access for any service requirements.

1

All horizontal pipes should have a minimum fall of 1:100. Discharge pipework should be uPVC. **Do not use 'pushfit' pipework/fittings.**

2

If a vertical rise is needed, this should be at the start of the run (within 30 cm of the unit) and from the high point there must be a minimum fall of 1:100 (see Rule 1).

3

Bends should be smooth/long radius, not tight elbows. Examples of uPVC pressure pipe and fittings shown.

4

Waste pipes entering the Saniflo unit should have a gravity fall of 1:40 or 3%.

5

Where the pipework falls below floor level increase the pipe size to break siphonage.

6

Each Saniflo discharge pipe should run separately to the sewer/vent pipe. If wastes are combined, it can only be to a larger pipe, which is on a gravity fall.

7

The unit should be easily accessible and removable in the event of service or maintenance being required. If boxed in, the boxing should be easily removed. Any extension between the WC pan spigot and wall should not exceed 200 mm and have a 1.40 fall.

8

As close coupled cistern dimensions vary it may be necessary with certain designs to use a spacer between cistern and wall.

9

Position the Saniflo unit directly behind the toilet pan, not underneath it.

10 **ELECTRICAL CLASS 1 PRODUCT**

























Connect to power according AS 3000 Electrical Regulation as rules apply depending on location.

For technical support in AUS: 1300 554 779 or technical@saniflo.com.au
 For technical support in NZ: 0800107264 or technical@saniflo.co.nz

With more than 60 years experience delivering innovative plumbing solutions Saniflo will guide you through the process. Contact our friendly team today to find out about our network of professional installers and suppliers.

AU 1300 554 779 / NZ 0800 107 264



- | | |
|---|---|
|  Groupe SFA International, France |  SFA SANIBROY, Germany |
|  SANIFLO AB, Sweden |  SFA BENELUX BV, Netherlands |
|  SANIFLO, England |  SFA SANIRISH, Ireland |
|  SFA, Poland |  SFA SANIFLO INC., USA |
|  SFA, Russia |  SFA SANIFLO INC., Canada |
|  SFA SANIBROYEUR, Belgium |  SFA SANITRIT, Italy |
| |  SFA SANIBROY, Slovenia |
| | |
|  SFA GRUPO, Spain |  SANIFLO, Australia |
|  SFA, Portugal |  SANIFLO, New Zealand |
|  SFA SANIFLO SRL, Romania |  SFASANIHYDRO, Turkey |
|  SANIFLO, Austria |  SFA, Japan |
|  SFA SANIBROY, Czech Republic |  SFA, China |
|  SFA SANIBROY, Switzerland | |

ABOUT SANIFLO

Saniflo is a brand created and owned by the French owned SFA Group . For over 60 years the SFA Group's goal has been to allow one to easily install toilets, showers, sinks, kitchens, baths and hand basins literally anywhere. From its early beginnings as the inventor of the domestic macerating system, the SFA Group is today amongst the main companies providing pump solutions worldwide. Synonymous with quality and technical expertise, Saniflo's made in France products comply with the strictest quality requirements and consistently meet customer expectations. Saniflo products all have Australian Watermark approval and their pumps are intended to be installed by licensed plumbers.

SANIFLO'S DESIGN SERVICE

Saniflo offers project consultancy and assists architects and hydraulic consultants by reviewing plans, assisting with design layouts and recommending the correct pumps and their ideal location. We even work with the plumber onsite during installation to ensure that everything goes as planned. Saniflo has a wide selection of products for domestic and commercial application to provide design flexibility.



Shaking up water



WMTS 106:2019
Certificate No. 23048
Manufacturer: SFA
Brand: Saniflo

SANIFLO AUSTRALASIA

Tel: 1300 554 779
General enquiries: info@saniflo.com.au
Technical & project support: technical@saniflo.com.au
WWW.SANIFLO.COM.AU

SANIFLO NEW ZEALAND

Tel: 0800107264
General enquiries: info@saniflo.co.nz
Technical & project support: technical@saniflo.com.au
WWW.SANIFLO.CO.NZ