

# RESIDENTIAL TRUE OAK® DEEP CORRUGATE WALL CLADDING EXTERNAL CORNER FLASHING FOR HORIZONTAL CLADDING

Detail No. RI-RTDW023A  
Date drawn: 01/02/2020  
Scale: 1 : 5@ A4  
Version: 01

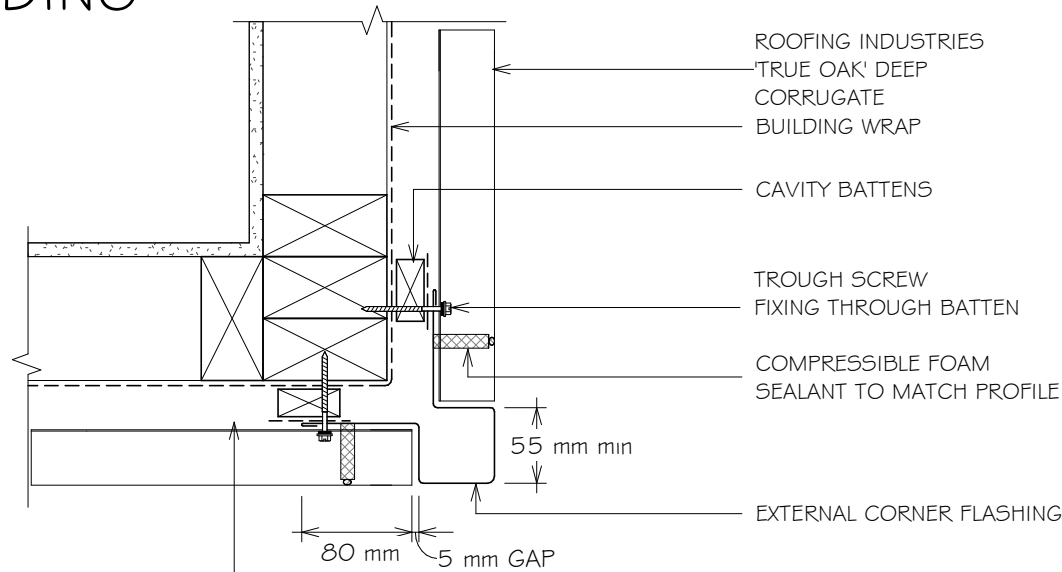

SEPARATION OF BATTEN  
AND METAL CLADDING

FLASHING TO COVER END  
OF METAL PROFILE CLADDING

NOTES:

1. MINIMUM 12 GAUGE WITH 30mm PENETRATION INTO FRAMING TIMBER TEKSCREW WITH NEO. (USE STEELTEK FOR STEEL FRAMING)
2. CAVITY BATTENS CONTAINING CORROSIVE MATERIAL MUST BE SEPARATED FROM METAL CLADDING BY DPC, BUILDING WRAP, PVC OR PAINTING.

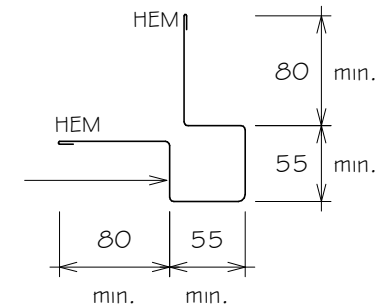

NOTES:

- These details are generally in compliance with E2/AS1 and/or the NZ Metal Roof & Wall Cladding Code of Practice and in some cases specific details by 'Roofing Industries'.
- The building designer is ultimately responsible to ensure that details used meet the requirements of the NZ Building Code for the specific project.
- Details of the supporting structure including cavity battens are indicative only and are the responsibility of the building designer. For steel framed buildings thermal break cavity battens may be required.
- Underlay selection and building wrap types are the responsibility of the designer. When rigid wall underlay is required it is the designers responsibility to ensure the correct type is used and follow the manufacturers recommendation for installation.
- These details are for Roofing Industries profile/s as nominated and may not be applicable to other profiles.
- This drawing is the copyright of 'Roofing Industries' and can only be copied or reproduced with their permission.
- Further information can be obtained from the NZ Metal Roof & Wall Cladding Code of Practice: [www.metalroofing.org.nz](http://www.metalroofing.org.nz) or E2/AS1.

Copyright detail © 2020

