

# RESIDENTIAL TRUE OAK® DEEP CORRUGATE WALL CLADDING BALUSTRADE FOR VERTICAL CLADDING ON CAVITY

Detail No. RI-RTDWO11A-1

Date drawn: 01/02/2020

Scale: 1 : 5 @ A4

Version: 01

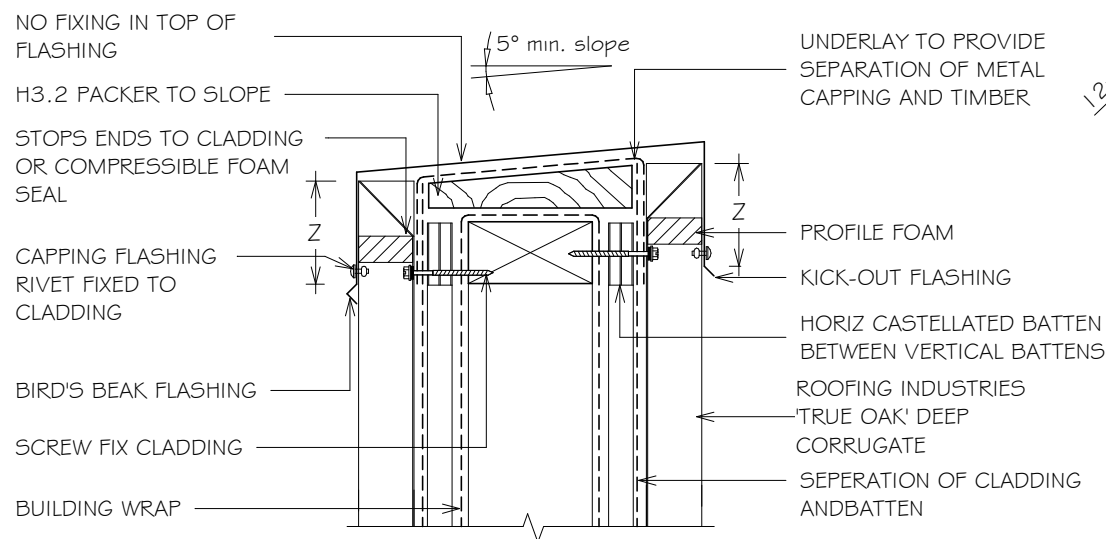

BIRD'S BEAK at bottom edge of vertical flashing

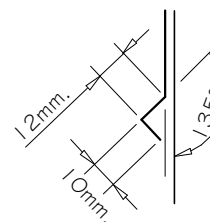

KICK-OUT at bottom edge of vertical flashing

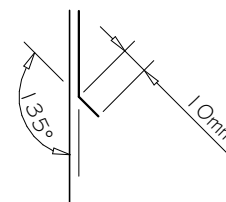

KICK-OUT hem at bottom edge of vertical flashing

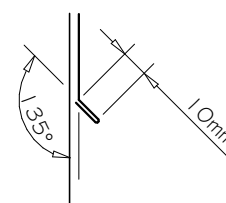

Bird's beak dimensions may vary between manufacturing locations

SITE WIND ZONE (As per NZS3604)	MINIMUM (mm)
SITUATION 1 <sup>(1)</sup>	75 <sup>(3)</sup>
SITUATION 2 <sup>(2)</sup>	100 <sup>(3)</sup>

NOTES:

- SITUATION 1: IN LOW, MEDIUM OR HIGH WIND ZONES.
- SITUATION 2: FOR VERY HIGH & EXTRA HIGH WIND ZONES.
- EXCLUDES DRIP EDGE.
- CAVITY BATTENS CONTAINING CORROSIVE MATERIAL MUST BE SEPARATED FROM METAL CLADDING BY DPC, BUILDING WRAP, PVC OR PAINTING
- CASTELLATED BATTEN, DRAINAGE PLASTIC BATTEN OR APPROVED DRAINED BATTEN CAN BE USED WITH THIS SYSTEM

NOTES:

- These details are generally in compliance with E2/AS1 and/or the NZ Metal Roof & Wall Cladding Code of Practice and in some cases specific details by 'Roofing Industries'.
- The building designer is ultimately responsible to ensure that details used meet the requirements of the NZ Building Code for the specific project.
- Details of the supporting structure including cavity battens are indicative only and are the responsibility of the building designer. For steel framed buildings thermal break cavity battens may be required.
- Underlay selection and building wrap types are the responsibility of the designer. When rigid wall underlay is required it is the designers responsibility to ensure the correct type is used and follow the manufacturers recommendation for installation.
- These details are for Roofing Industries profile/s as nominated and may not be applicable to other profiles.
- This drawing is the copyright of 'Roofing Industries' and can only be copied or reproduced with their permission.
- Further information can be obtained from the NZ Metal Roof & Wall Cladding Code of Practice: [www.metalroofing.org.nz](http://www.metalroofing.org.nz) or E2/AS1.

Copyright detail © 2020

