

RESIDENTIAL TRUE OAK® DEEP CORRUGATE ROOFING PARALLEL APRON FLASHING (CAVITY)

Detail No. RI-RTDRO10B
Date drawn: 01/02/2020
Scale: 1 : 5@ A4
Version: 01

CLADDING ON 20mm CAVITY BATTENS (3)
WITH BUILDING WRAP OVER FLASHING

PVC DRAINING CAVITY
BASE CLOSURE

SCREW FIXING

ROOFING INDUSTRIES
'TRUE OAK' DEEP
CORRUGATE

UNDERLAY

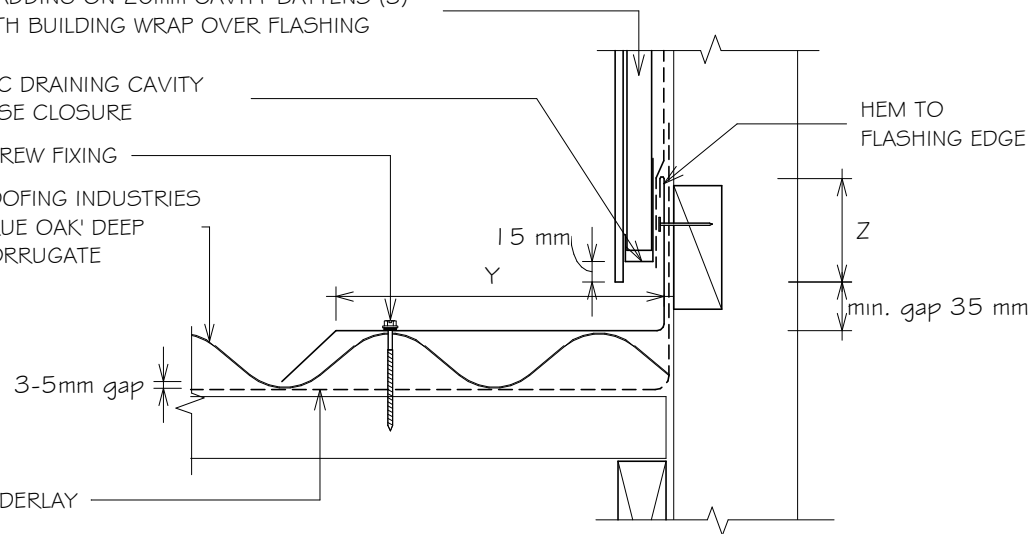

SITE WIND ZONE (As per NZS3604)	MINIMUM	
	Z	Y
SITUATION 1 ⁽¹⁾	75mm	2 crests
SITUATION 2 ⁽²⁾	100mm	3 "

NOTES:

DESIGNER TO ENSURE DURABILITY OF FLASHING MATERIAL;

- SITUATION 1: IN LOW, MEDIUM OR HIGH WIND ZONES, WHERE ROOF PITCH IS 10° OR GREATER
- SITUATION 2: FOR ALL ROOF PITCHES IN VERY HIGH AND EXTRA HIGH WIND ZONES, FOR ALL WIND ZONES WHERE ROOF PITCH IS LESS THAN 10°.
- CAVITY BATTENS OR PACKERS CONTAINING CORROSIVE MATERIAL MUST BE SEPARATED FROM METAL CLADDING BY DPC, BUILDING WRAP, PVC OR PAINTING

NOTES:

- These details are generally in compliance with E2/AS1 and/or the NZ Metal Roof & Wall Cladding Code of Practice and in some cases specific details by 'Roofing Industries'.
- The building designer is ultimately responsible to ensure that details used meet the requirements of the NZ Building Code for the specific project.
- Details of the supporting structure including cavity battens are indicative only and are the responsibility of the building designer. For steel framed buildings thermal break cavity battens may be required.
- Underlay selection and building wrap types are the responsibility of the designer, Netting or other support is generally required at roof pitches less than 8 degrees combined with a self supporting paper. At roof pitches of 8° and above where non self supporting paper is used or purlin spacing is in excess of self supporting criteria, netting or other support should be used. Alternative support to netting should be used in severe coastal environments including when aluminium is used.
- These details are for Roofing Industries profile/s as nominated and may not be applicable to other profiles.
- This drawing is the copyright of 'Roofing Industries' and can only be copied or reproduced with their permission.
- These details to be read with Roofing Industries profile technical summary regarding wind loads and fixings.
- Further information can be obtained from the NZ Metal Roof & Wall Cladding Code of Practice: www.metalroofing.org.nz or E2/AS1. Underlay selection and building wrap types are the responsibility of the designer, Netting or other support is generally required at roof pitches less than 8 degrees combined with a self supporting paper.

Copyright detail © 2020

