

INSTALLATION GUIDE

DriStud Wall Wrap

Fire Retardant Vapour Permeable Air Barrier Synthetic Wall Underlay

DriStud Wall Wrap is designed to be installed as a secondary protective weather resistant layer over exterior framing in accordance with NZBC, E2/AS1. When installing DriStud Wall Wrap the framing may either be timber or steel with absorbent and non-absorbent wall claddings direct fixed to framing. DriStud Wall Wrap can be used on both residential and commercial buildings.

WIND ZONES

DriStud Wall Wrap has been assessed as suitable for Wind Zones up to and including “**Very High**” when used as a flexible underlay and suitable for “**Extra High**” Wind Zones when used over a rigid wall underlay as defined in Table 5.4, NZS 3604:2011.

UV EXPOSURE

DriStud Wall Wrap can be exposed to UV for 60 days.

OVERLAPS / SUPPORT

- DriStud Wall Wrap can be installed horizontally and vertically with the printed side facing out.
- Horizontal laps should be overlapped no less than 75mm and vertical laps no less than 150mm. If possible, vertical laps should be over framing members or other solid backing.
- Where horizontal laps are required the upper sheet must overlap the bottom one to allow for moisture run off.
- Where a drained cavity is to be installed, cavity battens in accordance with E2/AS1 are acceptable. Use VB20 vented battens as non-structural cavity battens.
- DriStud Wall Wrap must be installed in accordance with paragraph 9.7.1, E2/AS1.

FIXING FOR WALL UNDERLAYS

Masonry Veneer – The fixing should be suitable for the permanent installation of the wall underlay without any assistance from the cladding.

Where the fixings are temporary, and the permanent installation relies on the cladding to hold the wall underlay on:

1. **Fixing to Timber Framing** – Secure DriStud Wall Wrap to framing using clouts (>20mm) or staples (>8mm galvanized) at no greater than 300mm centres.
2. **Fixing to Steel Framing** – Secure DriStud Wall Wrap to framing using double sided pressure

sensitive tape as a temporary means of fixing until battens are installed.

3. **Fixing to Rigid Air Barriers** – Staples (>8mm galvanized) or double-sided tape can be used as a temporary means of fixing. Fix the tape ends securely, particularly at any openings for doors or windows or use fasteners such as galvanized Little Grippers around each opening to be cut out.

Stud Spacing/Batten Spacing greater than 450mm:

Install DriStud Wall Wrap as above and use 75mm galvanized mesh (AS/NZS 4534) or polypropylene tape at 300mm centres fixed horizontally and drawn taut before installing the cavity battens.

INSTALLATION AROUND DOORS AND WINDOWS

The installer shall treat all wall openings (windows, electrical metres, etc) by cutting and folding the DriStud Wall Wrap as per the WANZ guide to window installation (E2/AS1 Amendment 6). All other penetrations to be sealed as E2/AS1.

- Cover all the openings with DriStud Wall Wrap until the windows and doors are ready for installation.
- The installer shall examine and confirm that the sill trimmer is level.
- Ensure that the framing is dry and free from debris before applying the DriStud Wall Wrap. (Refer to Detail 1)
- Cut the DriStud Wall Wrap and dress into all sides of the openings. Cut DriStud at 45° away from the corner. Fold the flaps tightly into the opening and secure to the framing on all sides. Trim off excess underlay after fixing. (Refer to Detail 2)
- Install DriStud Cool or Bozz window flashing tape over the bottom sill trimmer and be at least 200mm wider than the opening.
- Fit the flexible flashing tape to the inner edge with the outside edge extending a minimum of 100mm up each jamb.
- Ensure the tape is securely adhered to the underlay on all surfaces and fits tightly into each corner.
- Cut two more pieces of tape at least 200mm long to fit into each of the upper corners. Ensure the timber framing is covered. (Refer to Detail 3)

REPAIRS

If torn or punctured, cover over the damaged area with additional wrap with a minimum of 150mm overlap. Tape small tears or rips.

INSTALLATION GUIDE

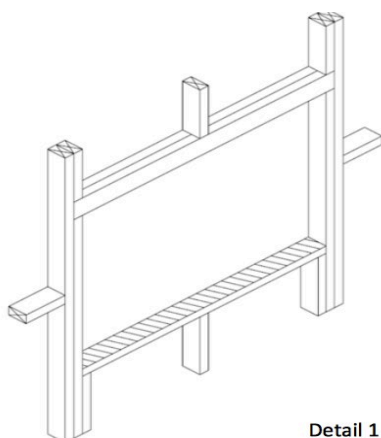

Detail 1

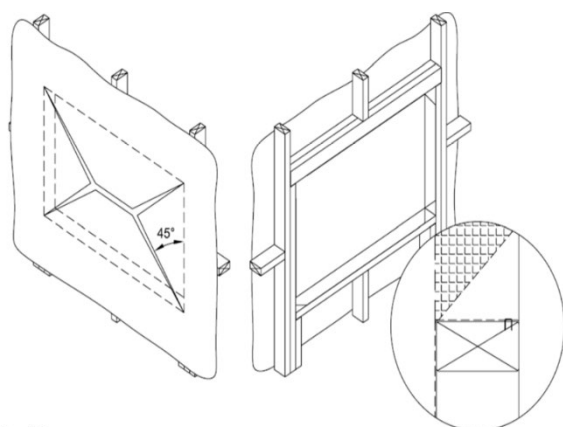

Detail 2

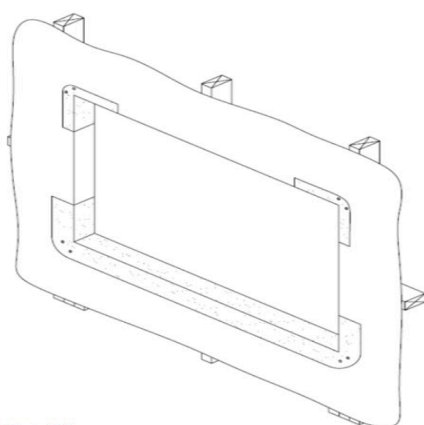

Detail 3

For further information please visit
www.drinspace.co.nz or call **0800 DRISTUD**
(374 7883).

STORAGE

DriStud Wall Wrap must be protected against damage and weather. Rolls must be stored under cover in a clean, dry environment.

SAFETY

- The Installer shall take all precautions to reduce work hazard.
- The installer of DriStud Wall Wrap is required to comply fully with Health and Safety in Employment Act 2002.
- Appropriate clothing, safety footwear and hand and face protection must be used in all cases.
- Safety scaffold and barriers must comply with the requirements of the Health and Safety in Employment Act and NZBC, F5 (Construction and demolition hazards)

WHO CAN INSTALL

The work should be undertaken or supervised by a Licensed Building Practitioner (LBP) or alternatively, the installer shall have the suitable skills when installing DriStud Wall Wrap as a part of an external water management system.