

# CONCRETE WITH BRICK VENEER

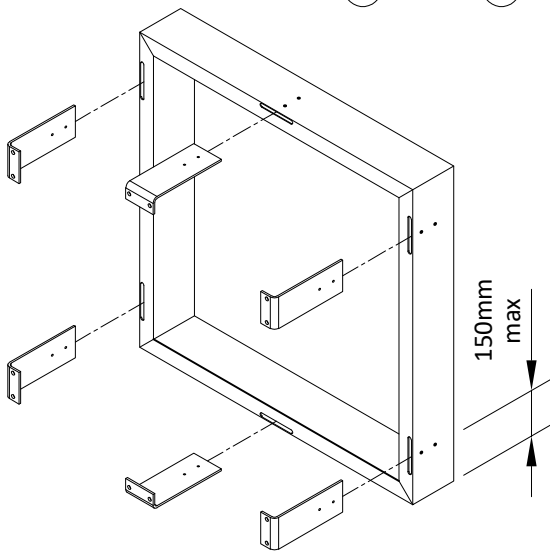
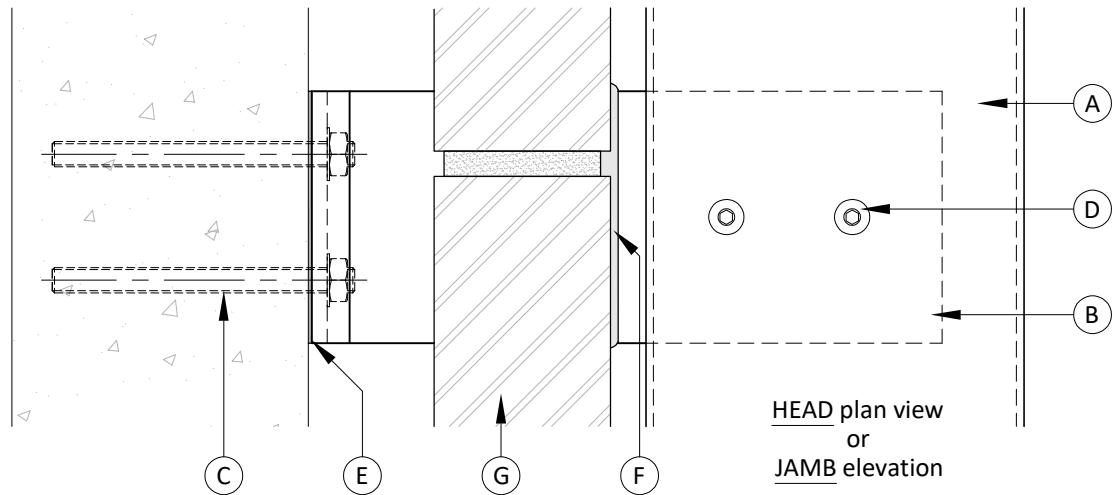
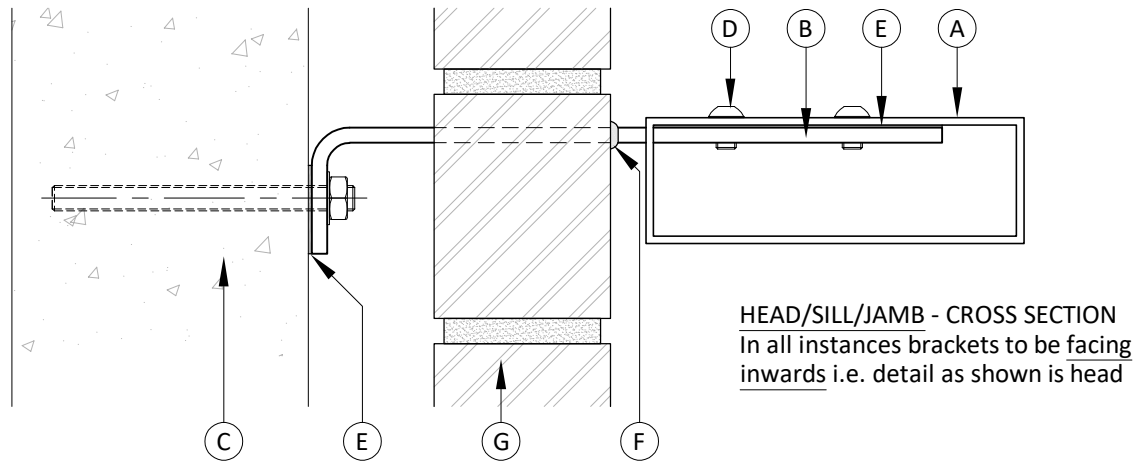

Description	
A	Window shroud (size as specified)
B	250 x 100 x 6 x 50mm stainless steel bracket (WS-B2)
C	(2x) M10 316 S/S threaded rod & chemset fixing with 90mm min embedment
D	(2x) M8 316 S/S button head capscrew
E	Plastic separation
F	Sealant (by others)
G	Brick veneer

All brackets to be facing inwards. Outer edge to centre of corner bracket = 150mm max. Corner brackets to be either vertically or horizontally positioned but not both.

Window Shroud section sizes				
150mm x 40mm	150mm x 50mm	200mm x 50mm	250mm x 50mm	300mm x 50mm

Wind Zones	Window Shroud section sizes					
	150mm x 40mm	150mm x 50mm	200mm x 50mm	250mm x 50mm	300mm x 50mm	
	Low (32m/s)	2.0m	2.0m	2.0m	2.0m	2.0m
	Medium (37m/s)	2.0m	2.0m	2.0m	1.7m	1.7m
	High (44m/s)	1.7m	1.7m	1.7m	1.4m	1.4m
Very High (50m/s)	1.5m	1.5m	1.5m	1.2m	1.2m	
Extra High (55m/s)	1.3m	1.3m	1.3m	1.0m	1.0m	