

COMMERCIAL CORRUGATE ROOFING HEAD BARGE (Soft Edge - Birds Beak)

Detail Number: RI-CCR003B

Date drawn: 01/08/2019

Scale: 1 : 5@ A4

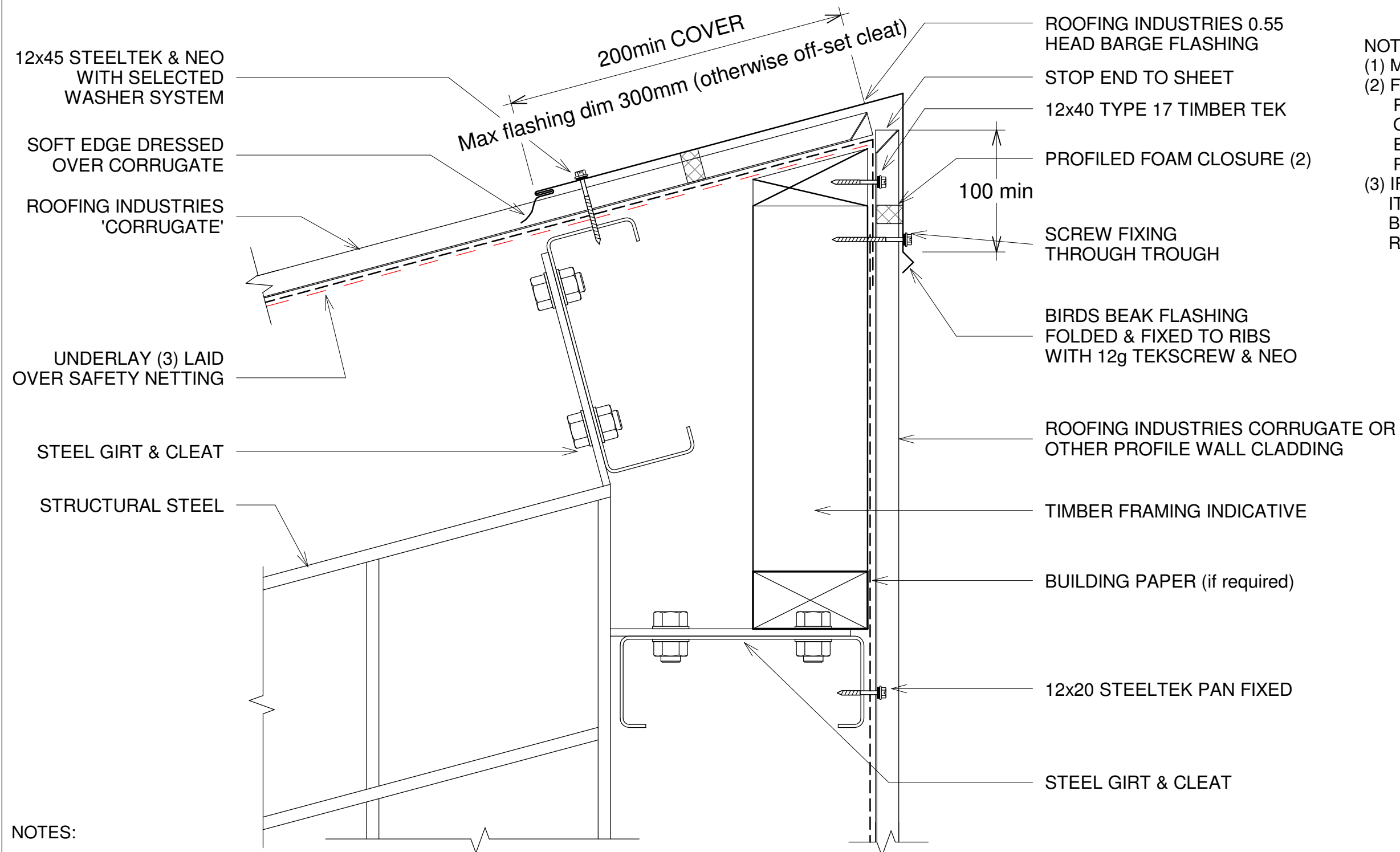

NOTE:

- (1) MINIMUM PITCH 8°
- (2) FOAM CLOSURE STRIP ONLY REQUIRED IN HIGH RISK SITUATIONS OF WIND BLOWN MOISTURE OR DRAFTS ENTERING OR IF BIRD OR VERMIN PROOFING IS REQUIRED.
- (3) IF UNDERLAY USED AS A VAPOUR BARRIER IT MAY REQUIRE A 20mm MIN AIR GAP BETWEEN THE UNDERSIDE OF THE ROOFING & UNDERLAY.

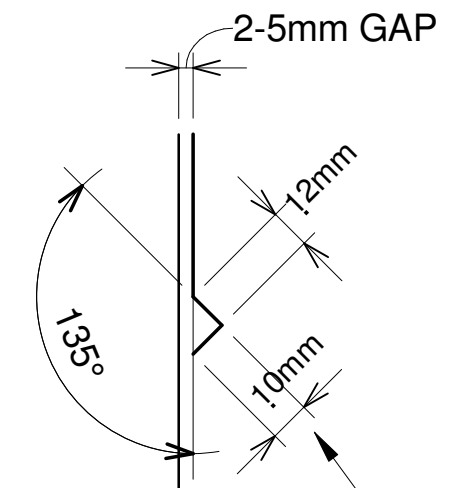

Birds beak dimension may vary between manufacturing locations

BIRD'S BEAK at bottom edge of vertical flashing

NOTES:

- These details are generally in compliance with E2/AS1, where applicable to profile, and the NZ Metal Roof & Wall Cladding Code of Practice and in some cases specific details by 'Roofing Industries'.
- The building designer is ultimately responsible to ensure that details used meet the requirements of the NZ Building Code for the specific project.
- Details of the supporting structure are indicative only and are the responsibility of the building designer.
- Thermal break or cavity battens may be required in some circumstances.
- Underlay selection and building wrap types are the responsibility of the designer. Alternative support to galvanised netting should be used in severe coastal environments including when aluminium is used.
- These details are for Roofing Industries profile/s as nominated and may not be applicable to other profiles.
- This drawing is the copyright of 'Roofing Industries' and can only be copied or reproduced with their permission.
- Further information can be obtained from the NZ Metal Roof & Wall Cladding Code of Practice: www.metalroofing.org.nz or E2/AS1.
- Where necessary, adjust drawings for purlin or cavity battens.
- Details are for steel based materials, other substrate may require some changes.

Copyright detail © 2019

