

CONCRETE - TOP FIXING, EPOXY-SET ANCHORS, 90MM CRS

Refer to all notes on Pages 100 and 101 which shall apply to this specification and the relevant pages in Chapter 5 Installation Guides. Refer also to Chapter 2 for the Style Specification.

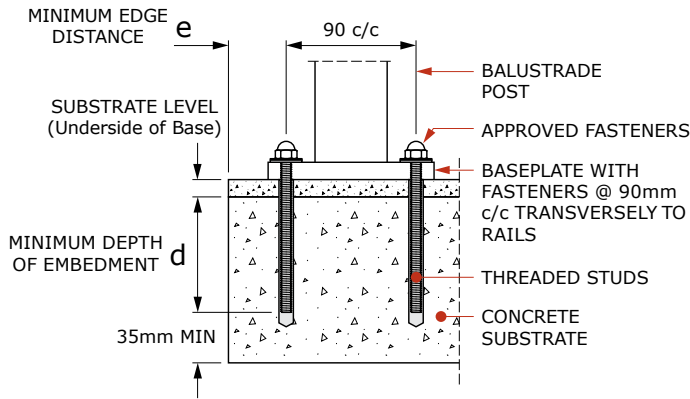

d = MINIMUM DEPTH OF EMBEDMENT INTO STRUCTURAL CONCRETE

e = MINIMUM DISTANCE FROM EDGE OF STRUCTURAL CONCRETE

1. For details of approved fasteners refer to General Notes on Page 100 note 3. All threaded studs shall have a minimum ultimate tensile stress of 560 MPa.
2. Washers to be fitted under all stud dome nuts as follows
 - For 8mm studs - 22mm O.D. S/S washer (Part No. FW8-22) with a polymer washer (Part No. FWP8-22G) between the S/S and the aluminium.
 - For 10mm studs - 21mm O.D. S/S washer (Part No. FW10-21) with a polymer washer (Part No. FWP10-22G) between the S/S and the aluminium.
3. For details of anchoring studs to the substrate refer to General Notes Page 101 note 6.
4. Substrate design, including waterproofing, is beyond the scope of this specification and shall be carried out by others. Concrete shall have a 28 day Compressive Strength of 20MPa or more (as required for substrate design) and be adequately reinforced.

MAXIMUM POST CENTRES 'S max' (metres) ALWAYS TAKE THE LESSER OF THE VALUE BELOW AND THE VALUE FROM THE STYLE SPECIFICATION																								
Height ⁽³⁾	Baseplate Size D x W	Fasteners - Qty and Type ⁽²⁾	'e' (See diagram)	'd' (See diagram)	Line No.	LOADING CLASS ⁽¹⁾																		
						N07C/N07R								N03R	Not Preventing Fall									
						Design Wind Speed ⁽⁴⁾									Design Wind Speed ⁽⁴⁾									
						VH	EH							M	H		VH		EH					
50	52	54	56	58	60	62	64	N/A	38	40	42	44	46	48	50	52	54	56						
1.0	115 x 90	2 x M8	40	80	1	0.89	0.89	0.89	0.88	0.83	0.77	0.72	0.68	1.90	1.73	1.73	1.57	1.43	1.31	1.20	1.11	1.02	0.95	0.88
		2 X M10	40	90	2	1.10	1.10	1.10	1.10	1.03	0.96	0.90	0.84	2.37	2.16	2.16	1.96	1.78	1.63	1.50	1.38	1.28	1.18	1.10
	115 X 105	4 x M8	40	80	3	1.75	1.75	1.75	1.74	1.63	1.52	1.42	1.34	3.76	3.40	3.40	3.10	2.83	2.59	2.37	2.19	2.02	1.88	1.74
		4 x M10	40	90	4	1.94	1.94	1.94	1.94	1.81	1.69	1.58	1.48	4.10	3.80	3.80	3.45	3.14	2.88	2.64	2.43	2.25	2.08	1.94
1.1	115 x 90	2 x M8	40	80	5	0.80	0.80	0.79	0.73	0.68	0.64	0.60	0.56	1.73	1.57	1.43	1.30	1.18	1.08	1.00	0.92	0.85	0.79	0.73
		2 X M10	40	90	6	1.00	1.00	0.98	0.91	0.85	0.80	0.74	0.70	2.16	1.96	1.79	1.62	1.48	1.35	1.24	1.14	1.05	0.98	0.91
	115 X 105	4 x M8	40	80	7	1.59	1.59	1.55	1.44	1.35	1.26	1.18	1.10	3.41	3.10	2.83	2.56	2.34	2.14	1.96	1.81	1.67	1.55	1.44
		4 x M10	40	90	8	1.77	1.77	1.72	1.60	1.50	1.40	1.31	1.23	3.79	3.46	3.14	2.85	2.60	2.38	2.18	2.01	1.86	1.72	1.60
1.2	115 x 90	2 x M8	40	80	9	0.74	0.71	0.66	0.61	0.57	0.54	0.50	0.47	1.58	1.33	1.20	1.09	1.00	0.91	0.84	0.77	0.71	0.66	0.61
		2 X M10	40	90	10	0.92	0.89	0.82	0.77	0.71	0.67	0.62	0.59	1.97	1.66	1.50	1.36	1.24	1.13	1.04	0.96	0.89	0.82	0.77
	115 X 105	4 x M8	40	80	11	1.46	1.40	1.30	1.21	1.13	1.06	0.99	0.93	3.13	2.63	2.38	2.16	1.96	1.80	1.65	1.52	1.40	1.30	1.21
		4 x M10	40	90	12	1.62	1.56	1.45	1.35	1.26	1.17	1.10	1.03	3.48	2.92	2.64	2.40	2.18	2.00	1.83	1.69	1.56	1.45	1.35

1. LOADING CLASS: Refer to Page 176 for the scope of the Loading Class designations.
 2. FASTENER DESIGNATIONS: M8 and M10 Fasteners in the table refer to UNEX Part No's FE8 and FE10 Threaded Studs.
 3. HEIGHT 'H': is the overall height of the balustrade above the substrate level shown. Interpolate for Heights between those shown.
 4. DESIGN WIND SPEED: in m/s, Refer to Pages 51 to 52 for details of applicable wind codes and the methods for determining the Design Wind Speed.