

## DRY TIMBER - SIDE FIXING, BOLTS

Refer to all notes on Pages 72 and 73 which shall apply to this specification and the relevant pages in Chapter 5 Installation Guides. Refer also to Chapter 2 for the Style Specification.

### APS & APE POST TYPES ONLY

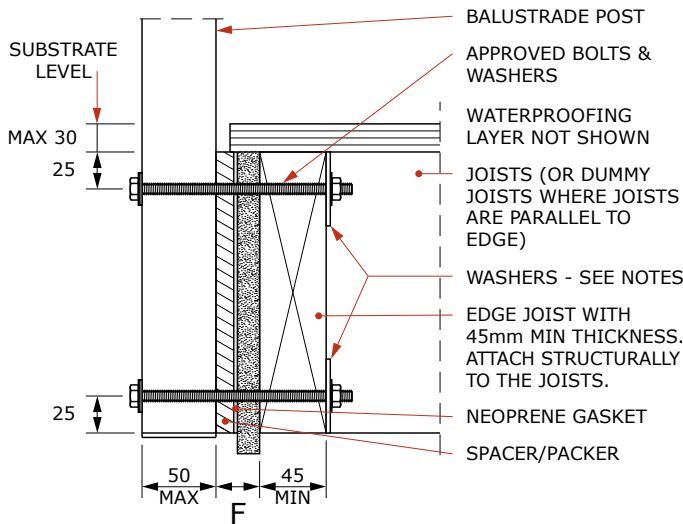

1. For details of approved fasteners refer to General Notes on Page 72 note 3.
2. Washers to be fitted under screw and bolt heads shall be as follows
  - For 8mm bolts - 22mm O.D. S/S washer (Part No. FW8-22) with a polymer washer (Part No. FWP8-22G) between the S/S and the aluminium.
  - For washers bearing against timber use 50 x 50 x 3mm stainless steel washers (Part No. FW10-50SQ).
3. SUBSTRATE design including waterproofing, the structural design of the timber members and their connections, is beyond the scope of this specification and must be carried out by others.
4. Spacings in Table below are based on Dry timber, using Pinus Radiata with a maximum in-service moisture content of 18%. For Wet timber, where the in-service moisture contents will exceed 18%, refer to specification FS.2S.06.03 on Page 92.
5. Substrate design including waterproofing and the structural design of the timber substrate and its connections are not included in this specification and must be carried out by others.

<span style="color: red;">!</span> <b>MAXIMUM POST CENTRES 'S max' (metres)</b> ALWAYS TAKE THE LESSER OF THE VALUE BELOW AND THE VALUE FROM THE STYLE SPECIFICATION																								
Height <sup>(3)</sup>	Post Type	Joist Size	Fasteners - Qty and Type <sup>(2)</sup>	'F' (See diagram)	Line No.	LOADING CLASS <sup>(1)</sup>																		
						N07C/N07R						N03R	Not Preventing Fall											
						Design Wind Speed <sup>(4)</sup>						M	Design Wind Speed <sup>(4)</sup>											
						VH	EH	VH	EH	VH	EH		H	VH	EH	VH	EH							
50	52	54	56	58	60	62	64	N/A	38	40	42	44	46	48	50	52	54	56						
<b>1.0</b>	APS APE	140	2 x M8 Bolts	NA	1	1.03	1.03	1.03	1.03	0.97	0.90	0.85	0.79	2.21	1.73	1.73	1.73	1.68	1.54	1.41	1.30	1.20	1.11	1.04
	APS	190+	2 x M8 Bolts	NA	2	1.26	1.26	1.26	1.26	1.22	1.14	1.07	1.00	2.70	2.25	2.25	2.25	2.12	1.94	1.78	1.64	1.52	1.41	1.31
	APE	190	2 x M8 Bolts	NA	3	1.50	1.50	1.50	1.50	1.49	1.39	1.30	1.22	3.22	2.41	2.41	2.41	2.41	2.37	2.17	2.00	1.85	1.72	1.60
	APE	240+	2 x M8 Bolts	NA	4	1.66	1.66	1.66	1.66	1.60	1.50	1.40	1.32	3.55	2.96	2.96	2.96	2.79	2.55	2.34	2.16	2.00	1.85	1.72
<b>1.1</b>	APS APE	140	2 x M8 Bolts	NA	5	0.95	0.95	0.93	0.87	0.81	0.76	0.71	0.66	2.03	1.46	1.46	1.46	1.40	1.28	1.18	1.09	1.01	0.93	0.87
	APS	190+	2 x M8 Bolts	NA	6	1.15	1.15	1.15	1.09	1.02	0.95	0.89	0.84	2.47	1.87	1.87	1.87	1.77	1.62	1.49	1.37	1.27	1.18	1.09
	APE	190	2 x M8 Bolts	NA	7	1.39	1.39	1.39	1.33	1.24	1.16	1.09	1.02	2.97	2.04	2.04	2.04	2.04	1.98	1.82	1.67	1.55	1.44	1.33
	APE	240+	2 x M8 Bolts	NA	8	1.52	1.52	1.52	1.43	1.34	1.25	1.17	1.10	3.25	2.47	2.47	2.47	2.32	2.12	1.95	1.80	1.66	1.54	1.43
<b>1.2</b>	APS APE	140	2 x M8 Bolts	NA	9	0.88	0.85	0.79	0.73	0.68	0.64	0.60	0.56	1.89	1.24	1.24	1.24	1.19	1.09	1.00	0.92	0.85	0.79	0.73
	APS	190+	2 x M8 Bolts	NA	10	1.06	1.06	1.00	0.93	0.86	0.81	0.76	0.71	2.27	1.59	1.59	1.59	1.50	1.37	1.26	1.16	1.07	1.00	0.93
	APE	190	2 x M8 Bolts	NA	11	1.29	1.29	1.22	1.13	1.05	0.99	0.92	0.87	2.75	1.76	1.76	1.76	1.76	1.68	1.54	1.42	1.31	1.22	1.13
	APE	240+	2 x M8 Bolts	NA	12	1.39	1.39	1.30	1.21	1.13	1.06	0.99	0.93	2.99	2.09	2.09	2.09	1.96	1.80	1.65	1.52	1.41	1.30	1.21

1. LOADING CLASS: Refer to Page 176 for the scope of the Loading Class designations.  
 2. FASTENER DESIGNATIONS: M8 Bolts in the table refer to UNEX Part No's FB8 bolts (Class 70 Stainless Steel), bolts may be substituted with FE8 (M8) Threaded Studs made from 316 Stainless Steel.  
 3. HEIGHT 'H': is the overall height of the balustrade above the substrate level shown. Interpolate for Heights between those shown.  
 4. DESIGN WIND SPEED: in m/s, Refer to Pages 51 to 52 for details of applicable wind codes and the methods for determining the Design Wind Speed.