

ASSEMBLY SPECIFICATIONS

NZBAL-B12.0 | SPEC ID AS.40.08T

'SPECTRA' (VRE TOP RAIL)

Refer elsewhere for corners, slopes and other situations not illustrated here.

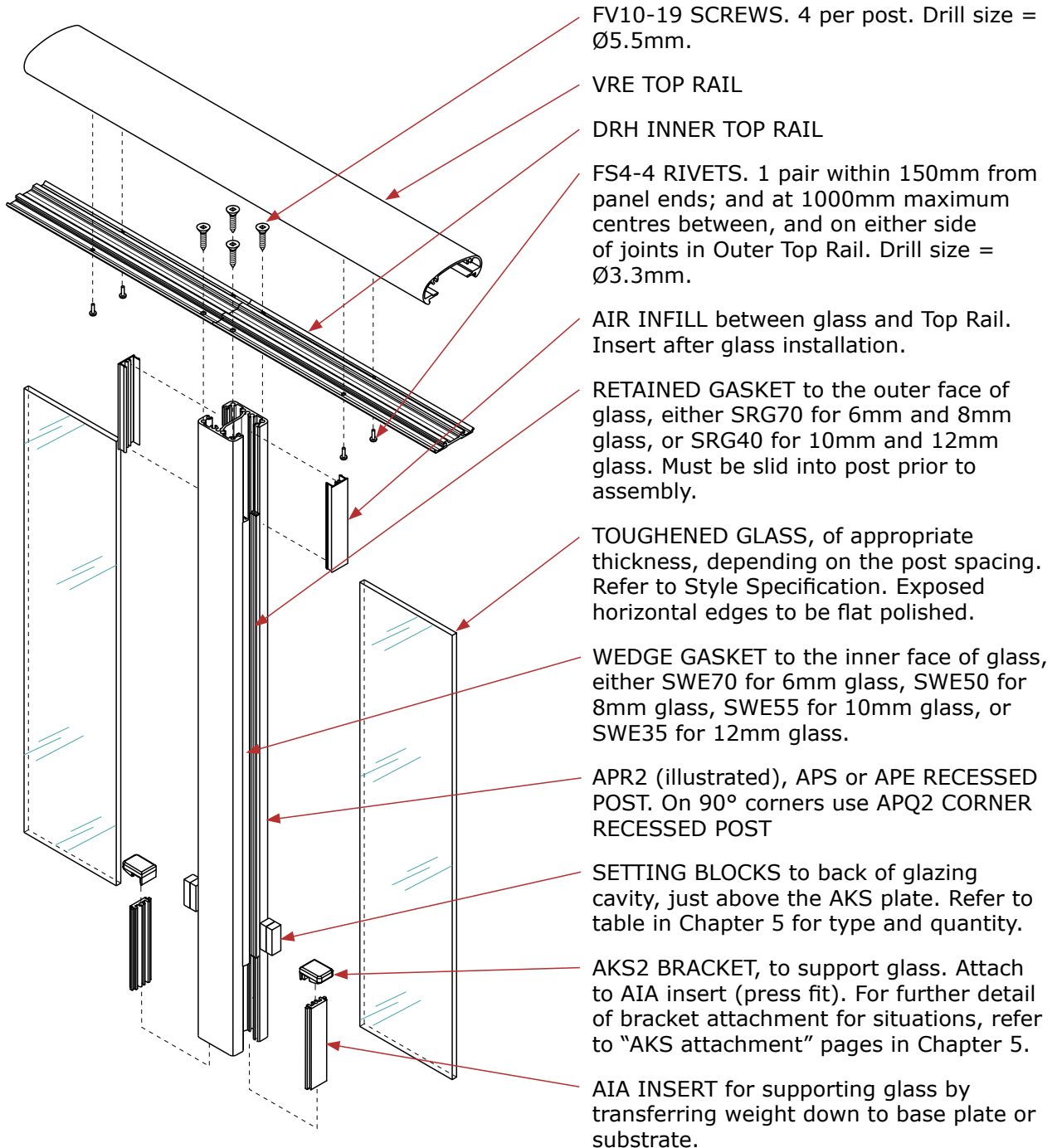

Specifications subject to change without notice