

ASSEMBLY SPECIFICATIONS

NZBAL-B12.0 | SPEC ID AS.40.05T

'SPECTRA' (ART TOP RAIL)

Refer elsewhere for corners, slopes and other situations not illustrated here.

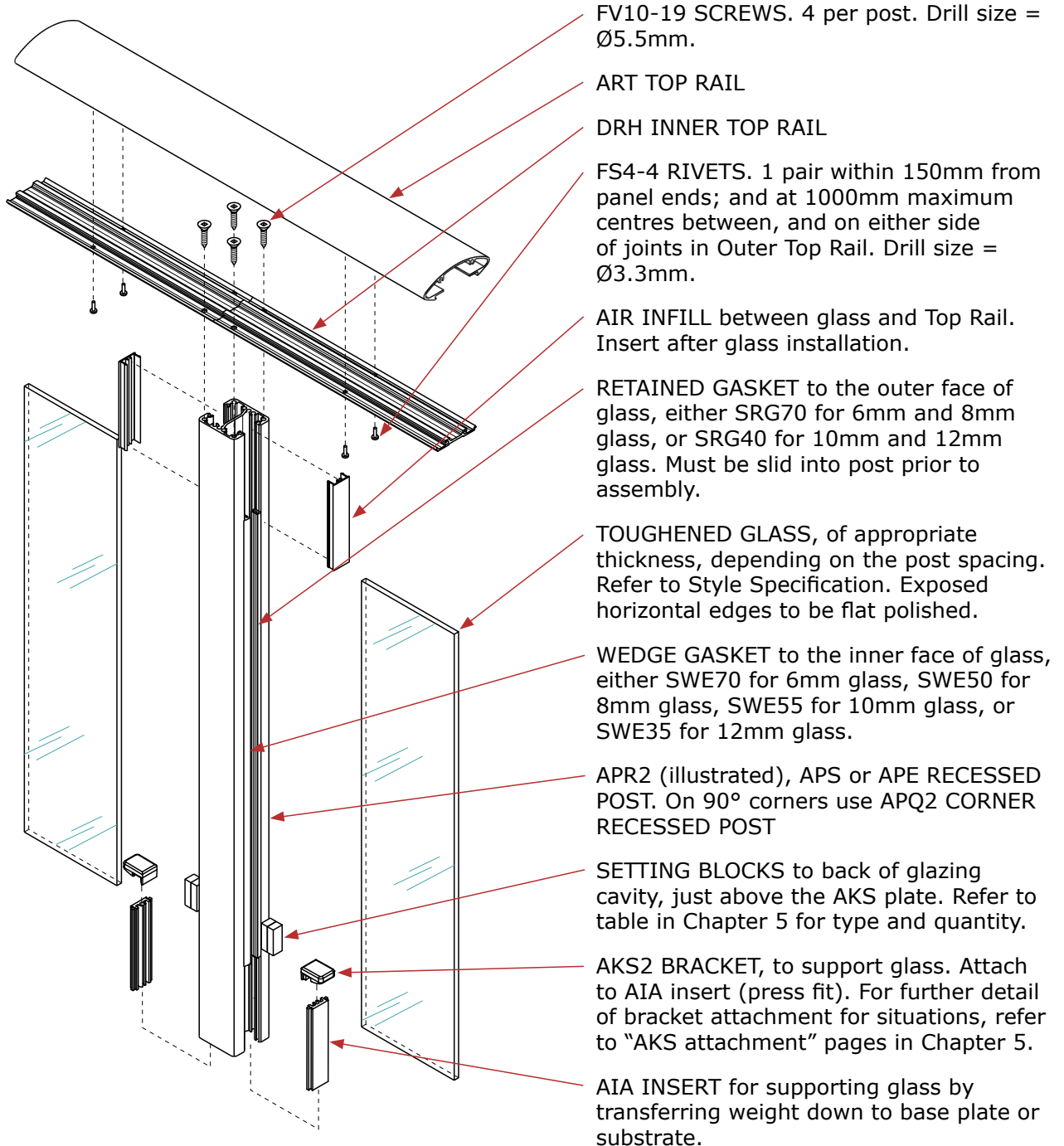

Extrusions & Components

Style Specifications

Fixing Specifications

Assembly Specifications

Fabrication & Installation

Specifications subject to change without notice