

ASSEMBLY SPECIFICATIONS

NZBAL-A12.0 | SPEC ID AS.01.08T

'ASCOT' (VRE TOP RAIL)

Refer elsewhere for corners, slopes and other situations not illustrated here.

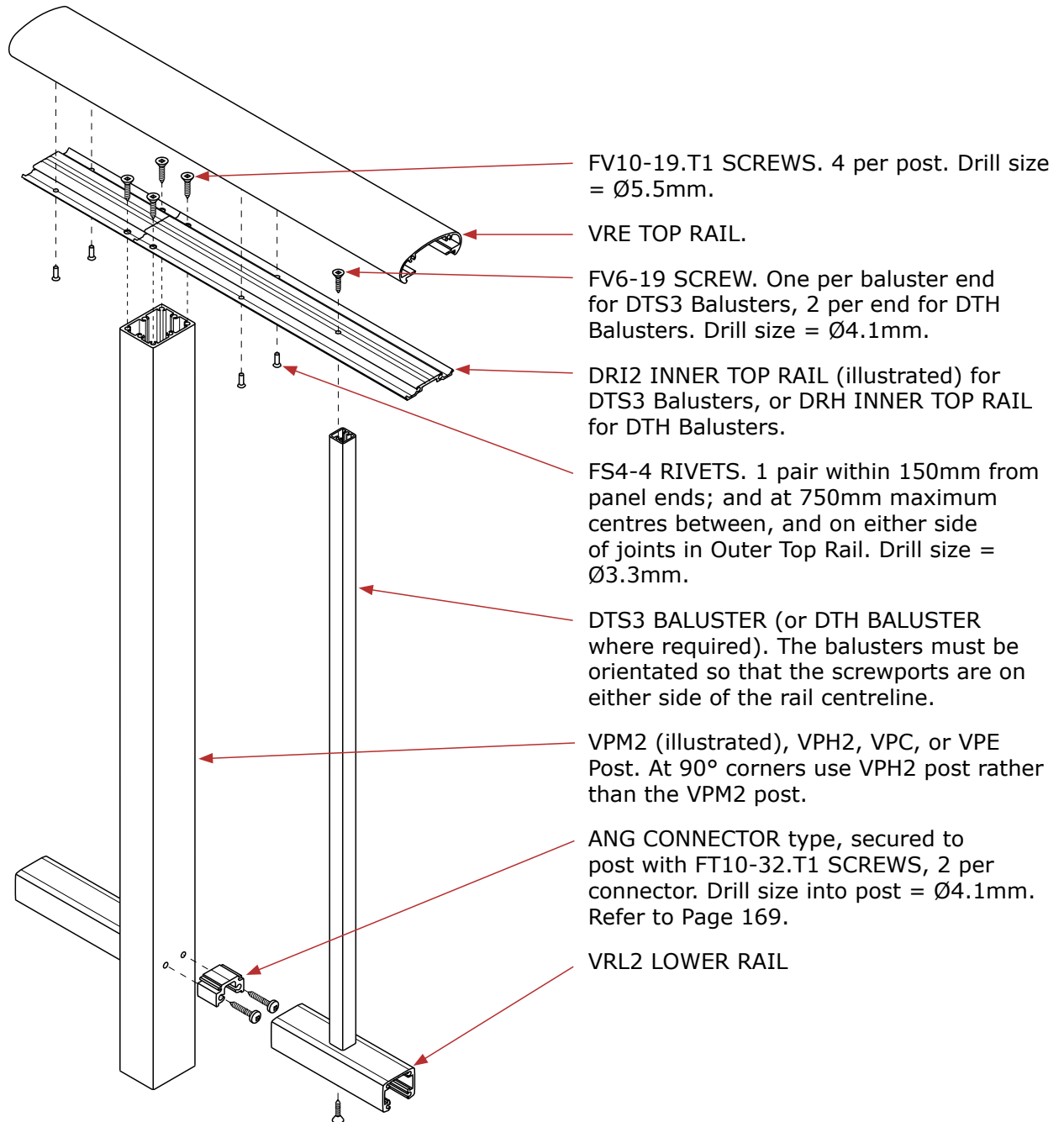

Specifications subject to change without notice