

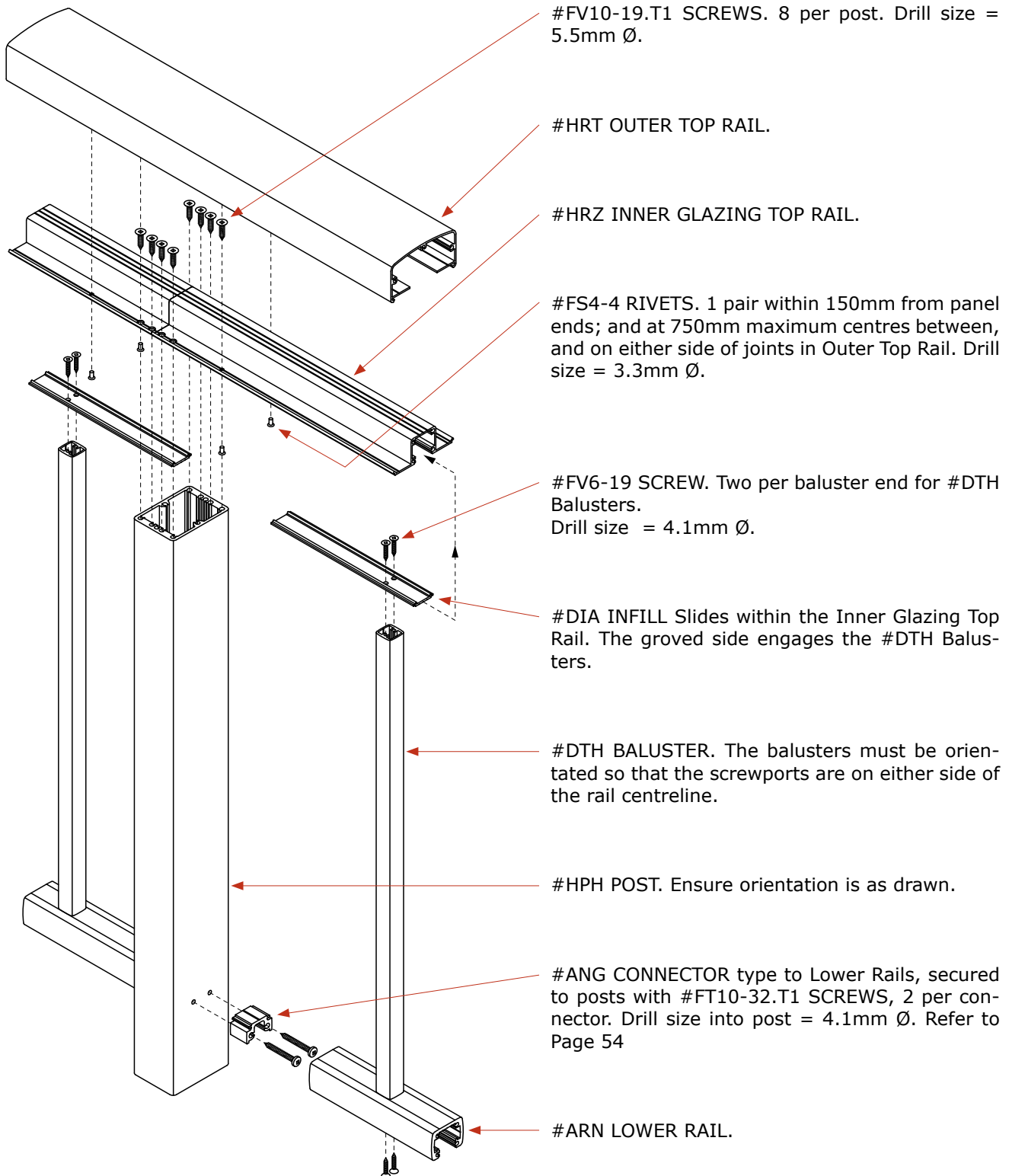

## X1500 BALUSTER - ASSEMBLY SPECIFICATION (EX-BA.01)A.01.31

Refer elsewhere for corners, slopes and other situations not illustrated here.



Specifications subject to change without notice



## X3000 BALUSTER - ASSEMBLY SPECIFICATION (EX-BA.01)A.01.51

Refer elsewhere for corners, slopes and other situations not illustrated here.

