

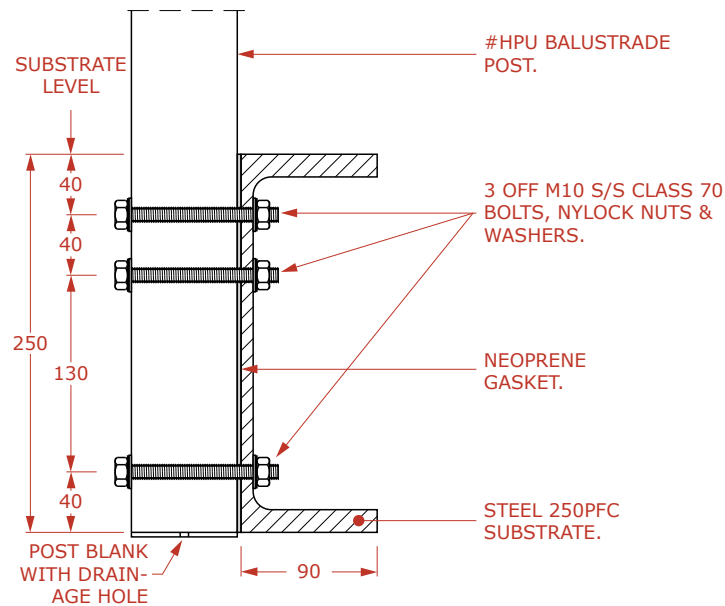

X1500, STEEL 250PFC SIDEFIXING, SPECIFICATION (EX-BA.01)F.54.31

This is a Standard Fixing Specification for the use of Extreme Barriers system, and must only be used in conjunction with the Specification Notes on page 38, and the relevant Style Specification on pages 14-19. Installation must be completed in accordance with the Installation Guide on pages 64-73.



THIS STANDARD SPECIFICATION IS COMPATIBLE WITH THE STYLE SPECIFICATION ON PAGES 14-19. REFER TO UNEX SYSTEMS FOR ALTERNATIVE STYLE SPECIFICATIONS AND NON-STANDARD FIXING METHODS.

NOTES RELATING TO THIS SPECIFICATION

1. M10 bolts are manufactured from 316 S/S and supplied by Unex Systems (M10 Bolts are Unex code FB10-XXX where XXX is replaced by the length in mm of the bolt e.g. FB10-100 is a 100mm M10 bolt). Where any element is positioned between the post and the substrate, the length of the bolt needs to be increased by the same amount to maintain enough protrusion to attach the nylock nut.
2. The balustrade post must be bearing directly and firmly on the supporting substrate. Any element in between must have an equivalent bearing strength and durability as the steel substrate.
3. Substrate design including waterproofing and structural design of the steel substrate and its connections are not included in this specification and must be carried out by others.