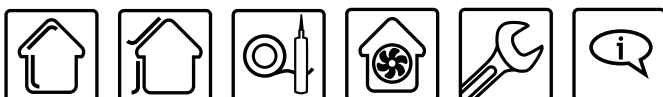


A NEW ZEALAND BASED STUDY ON AIRTIGHTNESS AND MOISTURE MANAGEMENT

Computer-based simulation of the combined heat and moisture transport of roof and wall constructions, taking the natural environmental conditions and moisture transport mechanisms within building materials into consideration



BUILDING PHYSICS STUDY

1. Summary and introduction

1.1	The building envelope – protection for the living environment	8
1.2	Thermally insulated building envelopes	8
1.3	Vapour diffusion flow	9
1.4.	Vapour diffusion flow in the summer	9
1.5.	Intelligent moisture management	9
1.6.	Moisture transport and living environment	10
1.7.	Mould resulting from damp building constructions	10
1.8.	Preventing structural damage and mould reliably	10
1.9.	The physical properties of moisture in the air	10
1.9.1.	During cooling: humidification, condensation, dew point	11
1.9.2.	During warming: drying, lower humidity, increased water absorption	11
1.10.	Conclusion	12

2. Mechanisms of moisture transport

2.1	Moisture transport: vapour diffusion flow	13
2.2	Moisture transport: vapour convection	14
2.3.	Moisture transport: damp building materials	15
2.4.	Moisture transport: thermal bridges	15
2.5.	Moisture transport: wrong construction sequence	15
2.6.	Moisture transport: moisture due to driving rain	16
2.7.	Moisture transport: ventilation systems	17
2.8.	Moisture transport: how vapour retarders work	17
2.9.	Moisture transport: how humidity-variable airtightness membrane work	18
2.10.	Moisture transport: conclusion	19

3. Consideration of the building physics and moisture balance in building constructions

3.1.	Calculation method	20
3.1.1.	Stationary calculation method in accordance with ISO 13788	20
3.1.2.	Non-stationary (dynamic) method	20
3.2.	Protecting building materials: calculation of the potential freedom from structural damage due to moisture	21
3.3.	Protecting building materials: consideration of the moisture behaviour of layers of building materials and their surfaces	21

4. Walls

4.1.	Boundary conditions and construction details	22
4.1.1.	Construction details of the wall	22
4.1.2.	Calculation with two different façades	23
4.1.3.	Environmental conditions and locations	23
4.1.4.	Layers critical to building physics with the risk of condensation	23
4.2.1.	Calculation of the moisture behaviour of layers of building materials and surfaces in Auckland	24
4.2.2.	Cement board – regular lime-stucco façade	24
4.2.3.	Wood cladding	24
4.3.1.	Calculation of the moisture behaviour of layers of building materials and surfaces in Wellington	25
4.3.2.	Cement board – regular lime-stucco façade	25
4.3.3.	Wood cladding	25
4.4.1.	Calculation of the moisture behaviour of layers of building materials and surfaces in Christchurch	26
4.4.2.	Cement board – regular lime-stucco façade	26
4.4.3.	Wood cladding	26
4.5.1.	Calculation of the moisture behaviour of layers of building materials and surfaces in Queenstown	27
4.5.2.	Cement board – regular lime-stucco façade	27
4.5.3.	Wood cladding	27
4.6.	Consideration of the results for walls, conclusion	28



5. Comparison of various types of wall wraps with regard to vapour permeability, raintightness and windtightness	
5.1. Vapour permeability	29
5.1.1. Results for Auckland	30
5.1.2. Results for Wellington	30
5.1.3. Results for Christchurch	31
5.1.4. Results for Queenstown	31
5.2. Raintightness	32
5.3. Windtightness	32
5.4. Conclusion	33
6. Roofs	
6.1. Thermal insulation and freedom from structural damage	34
6.2. Roof underlays	34
6.3. Skillion roofs	35
7. Quality assurance: inspection and measurement of the airtightness of the building envelope	36
7.1. Building leakage test	37
8. Thermal bridges	
8.1. Geometric thermal bridges	38
8.2. Structural thermal bridges	39
9. Notes on planning and construction	
9.1. Wall constructions and general information	40
9.2. Roof structures	41
9.3. Internal cladding	41
9.4. Permanently damp rooms	41
9.5. Moisture caused by residents and moisture in new buildings	41
9.5.1. Damp rooms in flats: the 60/10 rule	41
9.5.2. Increased humidity during the building phase: the 70/7.5 rule	41
9.6. Proper control of ventilation systems	42
9.7. The service cavity	42
9.8. Foam insulation	42
9.9. The right time for installing the airtightness membrane	43
9.10. Dry building materials when installing thermal insulation	43
9.11. Recycling and eco-friendliness	43
10. Installation	
10.1. Installation of the INTELLO membrane	43
10.2. Installation direction	43
10.3. Recommended pro clima system components for bonding and sealing	43
10.4. Connecting airtightness membrane to the floor	44
10.5. Dimensional stability	44
10.6. Mechanical strength	44
10.7. Translucent structure	44
10.8. Installation of cables and pipes in exterior walls	44
11. Conclusion and summary	45
Contact	45
References	46

We would like to thank

Paula Hugens

Glenn Murdoch

Christian Hörning

for reviewing this study for pro clima.

Lothar Moll
Thomas van Raamsdonk



Study of calculations of the potential for freedom from structural damage due to moisture in thermally insulated timber and steel frame construction

Preface

Energy efficiency, freedom from structural damage and a healthy indoor environment - rely on the right construction and intelligent moisture management

Good health depends on healthy living conditions

In comparison with the rest of the world, New Zealand has very clean air [1]. This is not so much due to effective environmental protection, as its geographic location and weather conditions. The islands run from North to South, extending some 1600 kilometres. They thus have a large contact surface for strong westerly winds, which constantly clean the air. Due to this cleansing effect, and the country's low population density, the anthropogenic environmental impact across New Zealand as a whole is relatively low [2].

In spite of the very low level of environmental pollution, New Zealand has one of the highest rates of asthma in the world. *One in six New Zealand adults and one in four of our children experience asthma symptoms* [3].

Asthma has a negative impact on the quality of life (for example inability to do sports, time spent off school by children, or the need to take medication). It also has a very severe impact on the economy [4], because of time spent off work and the enormous cost to the health system. It also has a cost in the terrible suffering endured by small children, who are often too young to understand asthma and frequently panic.

The Asthma Foundation writes:

“What causes asthma?”

We don't know why so many people have asthma. We do know that it is most common in English speaking countries like New Zealand, the United Kingdom, Australia, and the United States.

It may be related to 'modern living' - perhaps to changes to the environment, our diet, or different exposure to some infections. It is likely that all of these things have an effect, and hopefully in the future researchers will come up with a way of preventing people getting asthma” [5].

Given that modern living is cited as a possible cause of asthma, it is worth taking a closer look at the way we live. People who live a modern lifestyle spend over 90 per cent of their lives indoors and approximately two thirds in their homes [6] [7] [8]. It is therefore necessary to focus on the habitat in which we live, not just in the geographical sense,

but especially on the related personal living environment and the outer shell of buildings that surround it, the building envelope. It is worth taking a particular look at our living and working environments in comparison with other countries.

The air we breathe is indisputably one of the key factors that contributes to respiratory diseases. In general, the air in urban areas and industrial regions is liable to be polluted to a significant extent. This is for example, due to vehicles or industrial exhaust gases. What is much more decisive for our health, however, is the air quality in the rooms in which we live and work.

A cold indoor environment, means higher relative humidity (sometimes well over 80 per cent) due to the air's physical characteristics. This combination - cool and damp - in the long term, causes stress on the immune system and the respiratory tract.

High humidity levels resulting from low indoor temperatures favour the growth of mould on the surface of building materials. Mould needs no water to take hold or grow, a sustained high level of relative humidity (over 85 per cent) is sufficient [7] [9]. As many as 37 per cent of New Zealand houses exhibit signs of indoor dampness such as water leakage or visible moulds on walls, floor or ceilings [10].

The growth of mould on building materials (visible mould) is caused by cold surfaces which arise in the vicinity of thermal bridges. Thermal bridges are, to put it metaphorically, bridges that allow energy to pass through constructions that are otherwise insulated. In other words, they are places where heat is rapidly transmitted to the colder side of the construction. There are two distinct types of thermal bridge: those caused by geometry and those caused by material change. Thermal bridges caused by geometry can be found, for example, in corners and junctions of building elements such as windows or in projecting ceilings, etc.

Thermal bridges caused by materials can be found in thermally conductive materials such as those used in steel frame construction or uninsulated steel beams in external structural components.

See chapter 8 Thermal Bridges.

Mould within constructions (invisible mould) is also favoured by high levels of relative humidity in the living and working environment. In contrast to mould on the

surfaces, the cause of this is primarily infiltration through the building envelope, i.e. poor airtightness [11]. The indoor air that penetrates the gaps in the inner lining cools, this can then result in moisture in the construction, thus resulting in mould [7] [12]. Moulds thrive in damp environments, and it has been demonstrated that water damage which persists for more than three days causes an increase in the levels of spores inside a building.

Ventilation systems are another risk factor. The original intention of these systems was actually that they should promote a healthier indoor environment. If they are properly designed, serviced and adjusted, they can indeed be beneficial. If, however, ventilation systems are operated with overpressure in the winter, i.e. so that they press air into the building (for example in order to dry surfaces and windows), this air is also pressed into the building envelope. The result of this is that a disproportionately higher amount of moisture is transported through gaps in the construction, allowing mould to grow within thermally insulated constructions. The better sealed the building envelope is, the more effective and easier to control ventilation systems are, especially those with heat recovery. Unfortunately, this is rather theoretical in conventional constructions. In practice, old buildings and most new buildings do not have an airtight building envelope. The ideal solution for freedom from structural damage and healthy indoor environment would be a ventilation system that regulated itself according to the environmental conditions. It would provide suction through a slight underpressure in wintery conditions and blow in by means of a slight overpressure in summery conditions.

In addition to cold, damp indoor environments, exposure to mould and mildew is significant in relation to the development of respiratory health and asthma [7] [13-18]. The adverse effect of dampness on respiratory health has been suspected for many years, and large cross-sectional prevalence studies on both adults and children have confirmed a positive relationship between indoor dampness and respiratory symptoms and asthma. Meta-analysis performed by Peat et al. adds further support to these findings. In a Nordic review on the subject the authors conclude by stating:

“The review shows that “dampness” in buildings appears to increase the risk for health effects in the airways, such as cough, wheeze and asthma. Mould and mildew are considered to be allergens, as they irritate and stress the immune system. Allergic (extrinsic) asthma is far more widespread (approximately 85 per cent) than non-allergic (intrinsic) asthma. The allergies are then named after what triggers them, for example, allergies to animal hair, pollen, dust mites, food, asthma, etc., but not after the actual cause”[18].

Although mould spores have no smell, microbial volatile organic compounds (MVOCs), which are excreted by mould and mildew, do have a smell. The compounds can have a negative impact, in particular on the health of people with a weak immune system: young children, the sick and elderly. Finally, there are mycose. These are fungal diseases in the body that can also have an impact on health.

The allergenic and illness-inducing effect of mould in food has been well-known for years, but the fact that mould (spores and MVOCs) in the air also poses a threat is only gradually gaining recognition amongst the population. The most important types of mould that trigger allergies are **Aspergillus**, **Cladosporium** and **Alternaria**. These are all types of mould that can occur in food as well as in the construction (on the surfaces as well as within the construction of the building). While gastric acid in our body acts as a barrier against mould in food - by attacking the mould spores - the lungs have absolutely no protection against the spores or other compounds produced by mould that are breathed in. Mould particles that are breathed in are then taken up directly by the body which then has to fight to free itself of them. Essentially, the air we breathe that is contaminated with mould spores is more critical than food contaminated with mould [7] [19]. The mechanisms by which dampness is associated with respiratory symptoms and asthma are as of the current date still unknown. A relationship has been reported between allergic sensitization to moulds and asthma severity [7].

The objective is thus to improve the quality of air and the quality of life in the living and working environment, to ensure it is a warmer, drier, less mouldy and healthier. By taking relatively simple measures it is also possible to create a healthy indoor environment with a high level of protection against structural damage and an energy efficient construction. This can be achieved by:

- **Intelligent and fully functional sealing of the inner building envelope (airtightness and intelligent moisture management)**
- **Better thermal insulation (without thermal bridges and with greater thickness of insulation)**
- **Intelligent ventilation systems (adapting the air pressure direction to suit the environmental conditions).**

The World Health Organisation (WHO) has called for indoor temperature to be at least 18 degrees celsius, even in the winter, particularly to avoid the health impact and burden on the immune system and the respiratory tract [20]. The prevention of mould growth in the living environment has to become a matter of course in the future. A healthy living environment - warm, dry and free of mould - is especially important for young children, who spend most of the early part of their lives in enclosed spaces and experience their formative years indoors. Their health is at stake. Elderly and sick people also require higher temperatures and lower humidities to safeguard their health.

Governmental organisations such as the Energy Efficiency and Conservation Authority (EECA) support the application of building methods to promote a healthy living environment, freedom from structural damage and energy efficiency [21] [22] [23].

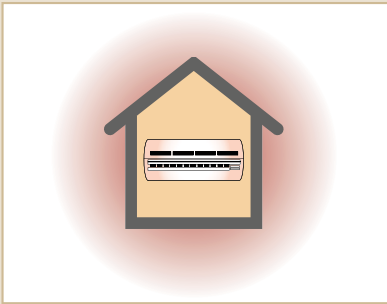


This study is dedicated to the children of New Zealand. It aims to contribute towards as many of them as possible, so they receive a good start in life, based on healthy living conditions.

**“Health is not everything,
but without health, everything is nothing.”**

ARTHUR SCHOPENHAUER (1788-1860)

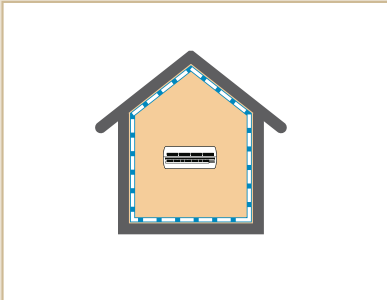
Fig. 1.
Non-airtight building envelope



The consequences are:

- Low indoor temperatures in the winter, despite high heating costs
- High indoor temperatures in the summer during daytime
- Unhealthy indoor environment

Fig. 2.
An airtight, insulated building envelope



An insulated construction with airtight sealing that works offers:

- A comfortable indoor environment
- Low heating costs
- Protection against structural damage due to moisture and mould
- Environmental protection due to lower CO₂ emissions

Fig. 3.
Mould in the building structure



Constructions that are not airtight do not only result in mould on the inner surfaces of structural components, but also in mould within the construction.

1. Summary and introduction

This study describes the building physics of:

- Moisture and air
- Moisture and constructions
- Moisture and building materials
- Moisture and mould
- Moisture and intelligent membranes
- Moisture and ventilation systems.

It presents possible solutions for living in a healthy and energy-efficient environment free of structural damage.

1.1. The building envelope – protection for the living environment

The building envelope, i.e. the walls, floor and roof, separates the living environment from the outdoor environment. It protects the residents from the elements and aims to make them independent of environmental influences.

Wall and roof elements are subjected to particularly high stresses due to the difference in the inside and outside environments.

Uninsulated constructions, as were normal for a long time in New Zealand, provide little protection against the outdoor environment and the elements. As a result of the lack of thermal insulation and airtight sealing layer, air is able to penetrate and escape from the structure at a relatively high flow rate. Due to the high flow rate there is low tendency for condensation to form, and thus a lower risk of mould growing within the construction.

However, uninsulated constructions are difficult to heat, resulting in low indoor temperatures in the winter, which are almost in the same range as the outdoor temperatures. This is accompanied by high levels of relative humidity. Mould generally forms on the (cold) inner surfaces in this type of building, especially in the region of thermal bridges, such as in the corners of a building.

A consequence of this is a very poor and, importantly, unhealthy living environment. If houses were heated to the minimum requirement of 18 degrees celsius there would be excess heating costs. In New Zealand there are few instances of excessive heating bills due to the constant under heating. In the winter it is too cold indoors, and in the summer it is too warm, see Fig. 1.

Insulated constructions are fundamentally different. Thermal insulation that works increases the surface temperature of building components on the inside. This results in a comfortable environment and helps to cut heating costs in the winter. The relative humidity indoors is lower in the winter and the living environment is healthier, see Fig. 2.

However, thermal insulation only works if the construction is protected from air flowing through it either from inside or from outside. Constructions that are not airtight not only result in mould on the inner surfaces of construction components, but also in mould within the building envelope, due to the low flow rate of the air. This results in a poor living environment, which – though warmer – is more prone to mould within the construction, see Fig. 3.

The transport of moisture within the construction follows the law of equilibrium: both insulated buildings and uninsulated buildings attempt to adapt to the ambient environment on each side, thus changing the state of the material. Towards the middle of the construction – depending on the insulating material used – the temperature and moisture level are reaching the mean level between inside and outside. Over the course of the day and through the seasons the roof and walls are constantly adapting to the changing conditions and influences.

1.2. Thermally insulated building envelopes

In the winter, thermally insulated buildings separate the warm indoor air, with its higher absolute humidity, from the cold outdoor air, with its lower absolute humidity.

In the summer, these buildings separate the warm outdoor air, with its higher

absolute humidity, from the indoor air, with its lower absolute humidity. This is accompanied by the risk of condensation (water condensing):

- On the external construction components in the winter
- On the internal construction components in the summer, see Figs. 4 & 5.

Whether water actually condenses depends on the amount of moisture that penetrates the construction and the diffusion resistance of the various layers of the construction. In the winter, the temperature within the building envelope drops towards the outside. Depending on the absolute humidity there is thus the risk that a temperature may be reached at which the air is no longer able to hold the moisture that it originally contained (the saturation temperature). It is therefore worthwhile to regulate the diffusion flow.

1.3. Vapour diffusion flow

If the vapour diffusion flow is limited (for example, by an intelligent airtightness membrane) and if the construction is open to diffusion on the outside, a certain amount of moisture that penetrates the construction is able to escape again without forming condensation.

If, on the other hand, there is a diffusion-inhibiting or even completely impermeable layer on the outside, the vapour is prevented from passing through and there is a risk of condensation.

There is no condensation if less moisture enters on the warm side than can escape on the cold side, or if more moisture can be given off on the cold side than enters the construction on the warm side.

There are thus two ways of influencing the moisture balance:

On the warmer layer, by limiting the diffusion flow, or on the colder layer by increasing the permeability for diffusion.

1.4 Vapour diffusion flow in the summer

Not only does diffusion take place in the winter from the inside to the outside, it also takes place from the outside to the inside in the summer. In the summer, the direction in which the moisture flows is inverted. The vapour partial pressure (the product of the temperature and the relative humidity) is then higher outdoors than indoors, see Fig. 5. What is ideal in the winter, a vapour retarder on the inside and a diffusion-open, vapour permeable layer on the outside can thus turn out to be detrimental in the summer, when the direction of diffusion is reversed. If you have the ideal situation for winter conditions, open to diffusion on the outside, you can end up with a lot of moisture penetrating from the outside in the summer. The vapour retarder on the inside then becomes a moisture trap on which the moisture from outside can condense. In other words, in the summer there needs to be a diffusion-open, vapour permeable layer on the inside, instead of a vapour retarder.

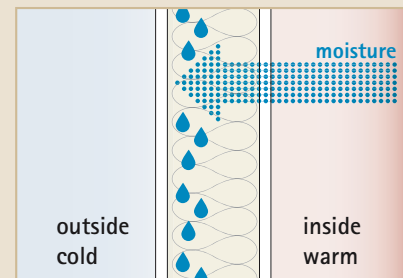
1.5. Intelligent moisture management

Intelligent moisture management that is capable of reacting to the current ambient conditions, i.e. by reducing diffusion in the winter and being permeable to permit diffusion in the summer, is ideal, see Fig. 6. These characteristics are provided by the intelligent airtightness and vapour check membrane pro clima INTELLO with variable diffusion resistance, which is laid on the inside:

- **Diffusion-reducing in the winter, when the vapour diffusion flow current is from the inside to the outside.**
- **Diffusion-open in the summer, when the vapour diffusion flow current is from the outside to the inside. See chapter 2.1, page 13.**

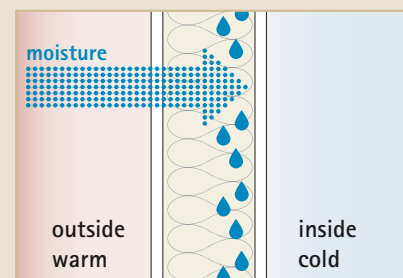
The airtightness of the building envelope ensures optimum effectiveness of the thermal insulation and thus a healthy living environment.

Fig. 4.
Condensation in winter



Outside colder than inside
-> condensation on the inside of the external surface

Fig. 5.
Condensation in summer

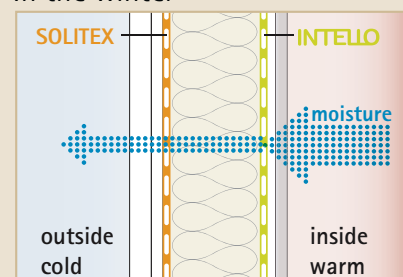


Outside warmer than inside
-> condensation on the outside of the internal surface

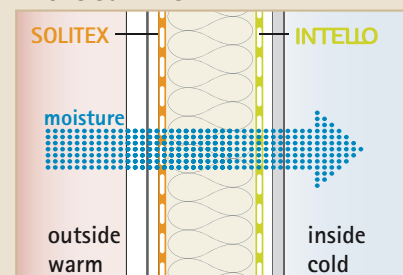
NOTE:

Condensation forms if more moisture enters on the warm side than can be escape on the cold side, or if less moisture can be given off on the cold side than enters the construction on the warm side.

Fig. 6.
Intelligent moisture management
In the winter



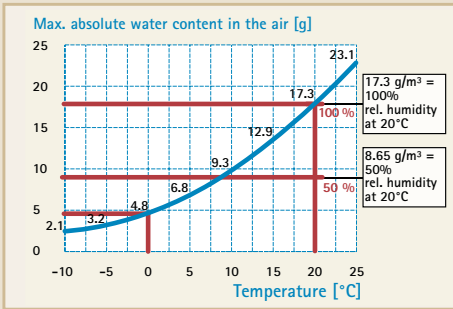
In the summer



Tab. 1.
Saturation humidity depending on temperature

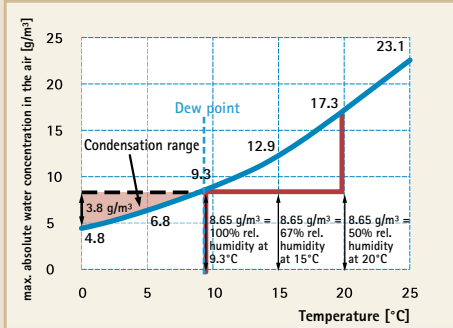
Temperature [°C]	-10	-5	0	5	10	15	20	25
Saturation humidity [g/m ³]	2.15	3.26	4.85	6.8	9.3	12.9	17.3	23.1

Fig. 7.
Determination of the absolute and relative humidity in the air



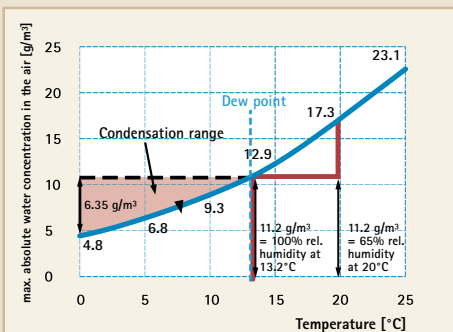
Air can hold different amounts of moisture, depending on its temperature.
At 20°C max. 17.3 g/m³, at 0°C max. 4.85 g/m³
A relative humidity of 50% is comfortable.
At 20°C this is 17.3 g/m³ x 0.5 = 8.65 g/m³

Fig. 8.
The physical behaviour of moisture in the air at 50% relative humidity



Under standard environmental conditions (20°C/50% relative humidity) the dew point is reached at 9.3°C. If the temperature drops to 0°C, 3.8 g/m³ of condensation is deposited.

Fig. 9.
The physical behaviour of moisture in the air at 65% relative humidity



At an elevated relative humidity of 65% the dew point is already reached at 13.2°C. If the temperature drops to 0°C, significantly more condensation is deposited: 6.35 g/m³.

Buildings with effective thermal insulation provide not only high energy efficiency, i.e. low heating costs, but also an ideal and healthy living environment that is warm and has an average humidity of 40 - 60 per cent (%).

The goal of the "Warm Up New Zealand" campaign, initiated by EECA is to have "Warmer, drier and more energy efficient" houses" [24].

1.6. Moisture transport and living environment

Moisture can enter the building envelope in two ways.

First and foremost is water vapour diffusion, which all building materials are confronted with. A physical principle is equilibrium. Natural systems always strive to reach an equilibrium.

Air indoors has a different partial pressure to air outdoors, and therefore attempts to reach an equilibrium due to the laws of physics. This causes it to drive the moisture through the building envelope. The water vapour moves from the warm side to the cold side of the material.

The second reason for moisture transport is air passing through the building envelope (convection). Air enters the construction through penetrations in the building envelope, e.g. driven by the difference in the air pressure on the two sides. If there is suction caused by wind on the outside, then warm indoor air flows into the building envelope, if there is wind pressure, air from outside flows into the building envelope. Both of these processes are capable of transporting additional moisture into the building envelope.

Intelligent airtightness systems can regulate the moisture balance in the outer parts of the "relative humidity", thus helping to keep the building free of condensation damage.

1.7. Mould resulting from damp building constructions

One of the most severe effects of moisture is the impact of mould spores on the health of people who live in buildings affected by mould. Furthermore, moisture also usually results in structural damage. Structural damage occurs if the moisture uptake is higher than a construction's drying capacity. To

avoid structural damage it is therefore necessary, on the one hand, to reduce the moisture uptake, and on the other hand increase the constructions drying capacity.

Apart from the moisture due to water leaking into the construction through the weathertightness layer and vapour diffusion, which can be calculated and allowed for, it is also necessary to take the effects of unanticipated moisture stress due to vapour convection (moisture transport through leaks in the airtightness layer) into account. The calculable or plannable moisture stress due to vapour diffusion flow is generally significantly lower than the unanticipated moisture stress due to vapour convection, for example, due to penetrations in the inner lining of the building envelope.

1.8. Preventing structural damage and mould reliably

To prevent structural damage and mould reliably, it is necessary to concentrate on the drying capacity of a construction - both in wintery conditions as well as in summery weather.

1.9. The physical properties of moisture in the air

The physical properties of moisture in the air are described by two parameters:

- ➔ Absolute humidity, and
- ➔ Relative humidity.

The absolute humidity is the amount of water vapour that is contained in one cubic meter (m³) of air gram per cubic meter (g/m³). The maximum amount of water vapour per m³ of air depends on the temperature of the air.

The amount of water vapour that the air can hold at a specific temperature is described as the saturation content. Warm air can absorb more water vapour than cold air. The temperature-dependent saturation values (100% humidity) for the maximum water content are given in **Table 1 and Fig. 7**. Air at a temperature of 20°C can hold an absolute maximum of 17.3 g of water per m³ of air, whereas

air at 0°C can only absorb 4.85 g/m³.

1.9.1. During cooling: humidification, condensation, dew point

If air is cooled while remaining at the same absolute humidity, the relative humidity increases. For example, if air is at a temperature of 20°C and 50% "relative humidity" (RH) it has an absolute moisture content of 8.65 g/m³. If this air then cools to 15°C, the relative humidity rises to 67%.

Calculation:

Absolute humidity at 20°C and 50% "relative humidity" = 8.65 g/m³
 8.65 g/m³ correspond to 67% of the saturation humidity (12.9 g/m³) at 15°C = 67% relative humidity at 15°C, see Fig. 8.

If the air cools even more, it will eventually reach the saturation temperature. Because air can only hold 100% of its saturation humidity, it will then reach its dew point, depending on its absolute water content, and condensation will form. In air at a temperature of 20°C and with a "relative humidity" of 50% (absolute = 8.65 g/m³) the dew point is reached at 9.3°C (saturation humidity of air at 9.3°C = 8.65 g/m³).

If the air cools even more, water will form as condensation. At 0°C the saturation humidity is then 4.85 g/m³. The amount of condensation is determined by calculating the difference between the saturation humidity at two different temperatures. In the example above, this is: 8.65 g/m³ minus 4.85 g/m³ = 3.80 g/m³ of condensation.

This means that each m³ of air at 20°C and 50% "relative humidity" deposits condensation amounting to 8.65 g minus 4.85 g = 3.80 g upon cooling to 0°C while passing through to the outside of the construction.

If, on the other hand, one takes a higher relative humidity as a starting value, e.g., 20°C and 65%, then the moisture content is higher (65% of 17.3 = 11.2 g/m³), the dew point is higher (13.2°C) and the amount of condensation upon cooling to 0°C (6.35 g/m³) is larger.

This means that each m³ of air at 20°C and 65% "relative humidity" deposits condensation amounting to 6.35 g upon cooling to 0°C while passing through to the outside of the construction, see Fig. 9.

1.9.2. During warming: drying, lower humidity, increased water absorption

During warming the opposite takes place. The air can hold more and more moisture the warmer it becomes.

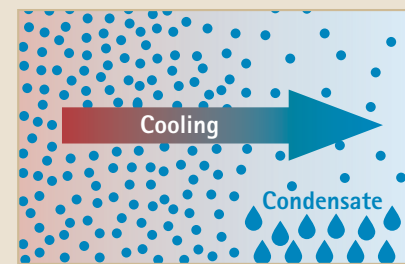
For example, take air at a temperature of 0°C and 80% relative humidity. The saturation humidity (100% relative humidity) is 4.85 g/m³ absolute humidity. This corresponds to 3.88 g/m³ at 80% relative humidity. If this air is then warmed to 20°C it can hold a maximum of 17.3 g/m³ of water (= 100%). The 3.88 g/m³ moisture in the air, absolute humidity, corresponds to a rel. humidity of 22.4% at 20°C, see Figs. 11 & 12.

That means that each m³ of air at 0°C that enters the building from outside only has a humidity of 22.4% once it has warmed up to the room temperature of 20°C. The result of this is that a warmer living environment generally tends to have a low relative humidity. From a health point of view, a relative humidity of about 50% is ideal, see Fig. 13.

In an airtight building envelope the water vapour released and generated by the occupants, for example by respiration and transpiration, cooking and washing, showering and bathing, from house plants and fountains used to moisten the air contribute to the overall humidity. If the airtightness is right, a comfortable ambient humidity of 50% should be reached naturally. The colder the outdoor climate in the winter (in Queenstown, for example), the lower the indoor relative humidity can become if the building envelope is not airtight.

Fig. 10.

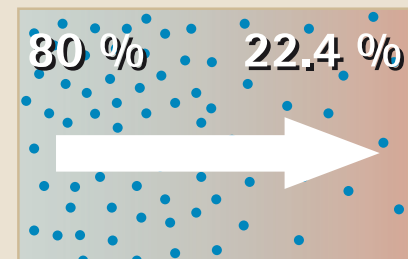
Condensation due to cooling



If warm air cools, condensate (condensation) may be deposited and there is a risk of structural damage and mould.

Fig. 11.

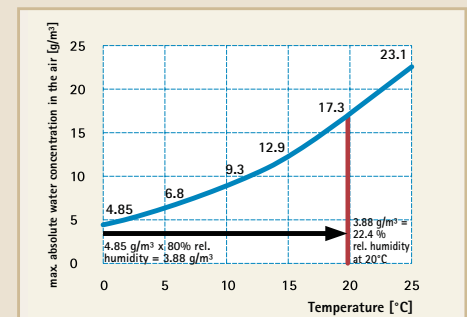
Reduction of the "relative humidity" due to warming



If cold air enters a warm room, the relative humidity in the room drops.

Fig. 12.

Air too dry due to warming



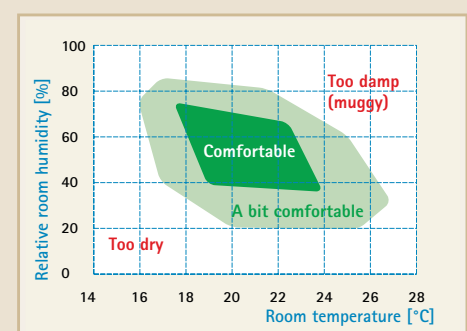
1 m³ of air at 0°C and 80% relative humidity is heated to 20°C.

Consequence: The relative humidity in the room drops to 22.4%. => too dry.

Comfortable and healthy air has a relative humidity of 50% and 18 - 21°C.

Fig. 13.

Comfort zone Indoor humidity-indoor temperature



According to Leusden and Freymark.

NOTE:

The ideal solution is to have an airtight building envelope that allows very little vapour diffusion flow to the outside in the winter, but allows the construction to dry out in the summer, either to the atmosphere or inside.

1.10. Conclusion

- The humidification and drying processes within a building envelope depend on the physical behaviour of moisture in the air.
- These processes are driven by the natural tendency to reach an equilibrium and pressure balance.
- The moisture always travels from the side with the higher water vapour partial pressure to the side with the lower water vapour partial pressure.
- The water vapour partial pressure is defined as the product of the temperature and the relative humidity. Ignoring the humidity, this can be simplified by saying that the moisture travels from the warm side to the cold side.
- If the air warms up, the relative humidity drops.
- If the air cools down, the relative humidity increases and the moisture is deposited as condensation if the air temperature falls below the dew point.
- Moisture caused by diffusion can be allowed for. Moisture caused by convection (air which enters the construction) cannot be allowed for and may lead to structural damage.
- Penetrations in the airtightness of the building envelope contribute towards a high level of moisture entering the construction.

Constructions catering for the need for:

- Protection against moisture in the winter, and
- A high drying potential in the summer.

Using airtightness membranes with a variable diffusion resistance provide good protection against structural damage, even in the event of unforeseen moisture stress.

2. Mechanisms of moisture transport

2.1. Moisture transport: vapour diffusion flow:

Vapour diffusion flow is the term for the ability of water vapour to pass through certain materials. The reason for this is the intrinsic thermal mobility of atoms, ions and molecules due to Brownian motion, see Fig. 14.

The amount of moisture that is able to penetrate a material is given by the difference in vapour partial pressure (the product of the temperature and the relative humidity) on each side of the material and the diffusion resistance of the material. Different variables are used for the diffusion resistance in different countries.

The vapour diffusion resistance (moisture vapour resistance) is determined by testing the material and is given in $\text{m}^2\text{sPa/kg}$. It always refers to a specific material under the test conditions, i.e. the type of material and the thickness of the sample.

For this reason, the international standard ISO 12572 only uses the vapour diffusion resistance as an interim value and converts it into a value that is independent of the material thickness, the μ value, also known as the water vapour diffusion resistance factor. On the basis of the μ value it is then possible to perform physical calculations to evaluate the moisture behaviour of the construction.

The value most commonly used for calculating the moisture transport within constructions is the s_d value, also known as the equivalent air layer thickness. This is given by the water vapour diffusion resistance factor μ (as a dimensionless material parameter) multiplied by the thickness of the layer of material in metres. The result obtained is the s_d value, given in meters [m]. The s_d value is the value used to compare a certain material to a static layer of air. The lower the s_d value, the lower the diffusion resistance and the more open the material is to diffusion.

The conversion of the s_d value to the moisture vapour resistance [MNs/g] as used in English speaking countries is performed by multiplying the s_d value by a factor of 5.1.

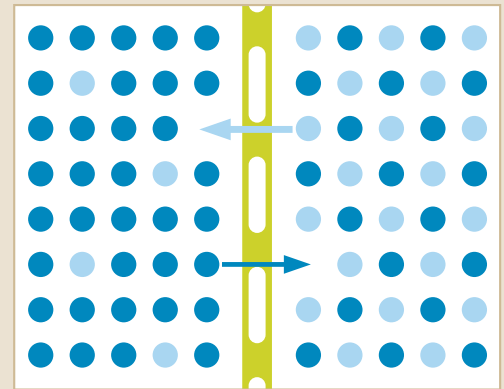
From the basic physical data on the material and the local climate it is possible to determine the amount of moisture that will diffuse through a construction. The following provides an example of the order of magnitude: plasterboard is diffusion-open and has a low moisture vapour resistance. This has several advantages in terms of building physics, but also has the effect that it allows moisture to penetrate constructions without a moisture control layer in wintery weather. Depending on the prevailing conditions, this may be as much as 100-150 gram per square meter (g/m^2) per day.

Structural damage due to condensation may result if the moisture that penetrates is unable to dry out again at the same speed.

Apart from depending on the diffusion flow, the moisture balance within the building materials also depends on the airtightness and on the local climate. Colder locations and locations with short summers are more critical when it comes to the moisture balance in winter. Warm locations and locations with long, humid summers are more critical when it comes to the moisture balance in the summer. In a South Island location (e.g. Christchurch or Queenstown) the condensation in winter is therefore more critical than in a North Island location (e.g. Auckland) and, conversely, indoor condensation in the summer is more critical in the North Island.

A vapour retarder is beneficial in wintery conditions, but it can cause problems in summery conditions, as the direction of diffusion flow can be reversed in the summer. The problem in the summer is not necessarily the amount of water vapour, but rather the critical combination of moisture and high summer temperatures inside the construction. Formation of condensation in the winter on the cold outer surface results in mould far less frequently and far more slowly due to the lower temperatures (comparable to the lower risk of mould in a fridge when it is on). In the summer, on the other hand, the conditions are almost ideal for mould to grow due to the high humidity and high temperature. Summer condensation is therefore extremely critical, in terms of a healthy living environment.

Fig. 14.
Diffusion



Moisture transport due to diffusion flow can be planned and allowed for.

NOTE:

The s_d value (diffusion resistance) specifies how open to diffusion a building material is. The lower the s_d value, the lower the diffusion resistance and the more open the material is to diffusion flow.

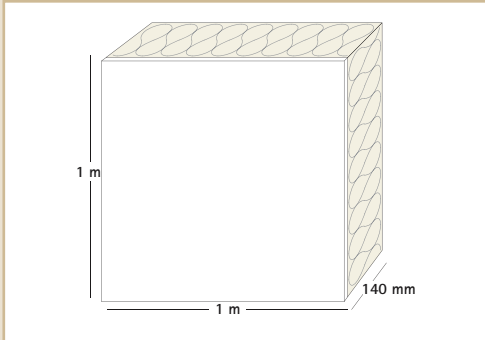
The units of the s_d value are [m]. In English speaking countries (excluding the US and Canada), the moisture vapour resistance is most commonly used. This is converted by multiplying the s_d value by a factor of 5.1. The units of the moisture vapour resistance are [MNs/g].

NOTE:

Plasterboard is diffusion-open. It has a low water vapour resistance (approx. 0.75 MNs/g). This has several advantages in terms of building physics, but also has the effect that it allows moisture to penetrate the building envelope without a moisture control layer in wintery weather. Depending on the prevailing conditions, this may be as much as 100-150 g/m^2 per day. Structural damage may result if the moisture that penetrates is unable to dry out again at the same speed.

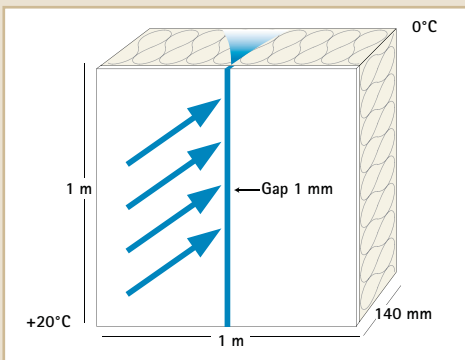
Moisture transports into the construction due to penetrations in the airtightness layer

Fig. 15. Moisture transport due to diffusion in winter



At an s_d value of 30 m (150 MNs/g)
Moisture transport in winter due to diffusion:
 $0.5 \text{ g/m}^2 \times 24 \text{ h}$

Fig. 16. Amount of moisture due to convection



Moisture transport

With a 1 mm gap: $800 \text{ g/m}^2 \times 24 \text{ h}$

Increased by a factor of: 1,600

Conditions:

Vapour retarder s_d value = 30 m (150 MNs/g)
Indoor temperature = +20°C
Outdoor temperature = 0°C
Pressure difference = 20 Pa corresponds to wind force 2-3

Measurement carried out by:

Fraunhofer Institute for Building Physics, Stuttgart

2.2. Moisture transport: vapour convection

Significantly larger amounts of moisture ("vapour convection") are transported into the building envelope by air passing through gaps and penetrations in the inner airtight sealing layer (convection) than by diffusion. The Fraunhofer Institute for Building Physics in Germany conducted an investigation and various studies into the effects of gaps in the airtightness layer in 1989 [25]. They measured the flow of moisture resulting from gaps of various widths and pressure differences at an indoor temperature of 20°C and an outdoor temperature of 0°C. They found the amount of moisture transported into the construction by convection to be 1000 times as much as that transported by diffusion. The structures not only displayed an extreme increase in the amount of moisture, but also a significant deterioration of their thermal insulation performance. These alarming findings led to Germany becoming the first country in the world to make airtightness of the building envelope a legal requirement in 1995.

The pilot setup was first tested with perfect airtightness. The moisture transport due to diffusion was negligible, at just 0.5 g/m^2 per day. A gap 1 millimeter (mm) in width and 1 meter (m) in length, at an outdoor temperature of 0°C and with a pressure difference of 20 pascal (Pa) (which corresponds approximately to wind force 2-3) allowed some 800 g/m^2 of water into the construction per day via air flow (vapour convection) and wider gaps allowed even more in.

Such quantities of moisture rapidly lead to the formation of condensation in thermally insulated timber and steel constructions, even on diffusion-open wall wraps. In building envelopes that are not thermally insulated, such as those to be found amongst New Zealand's old housing stock (e.g., state houses dating from 1930-1970), the moisture is carried out on the air flow unhindered, not halted by any thermal insulation or wall lining membrane. The air exchange rate (n_{50} value) of these old buildings was found to be as high as 35 air change per hour (ACH) [26]. The upside of this is that it generally

prevents condensation from forming. The downside, however, is the inadequate thermal insulation of the construction and the resulting poor quality living environment.

The measurements performed by the Fraunhofer Institute were subsequently reevaluated and confirmed by Prof. Pohl (Prof. Pohl, University of Hannover, Nomogram) and other researchers. This led to a rethink and ultimately had an effect on building regulations (standards), laws (e.g. thermal insulation regulations) and the building standards (practical construction work).

Unlike vapour diffusion flow, it is not yet possible to calculate the amount of vapour convection. Initial studies at the Fraunhofer Institute aim to close this gap. Vapour convection poses an immense risk of formation of condensation in all thermally insulated constructions, both in externally diffusion-open materials, but even more in externally diffusion-inhibiting materials. This is why building envelopes that are not airtight, but allow air flow through, are very susceptible to structural damage.

The construction methods common in New Zealand pose the risk that the vapour convection flow may cool on passing through the thermal insulation and form condensation on outer layer of the insulation.

From the above, it can be concluded that airtightness is an absolute necessity for healthy living. It is therefore advisable to measure the quality of the airtightness by means of a test, the Blower Door test. From practical experience it is a known fact that absolute 100% airtightness is impossible to achieve. Even high quality constructions need capacity for drying in order to avoid the formation of mould and prevent structural damage in the long term. For further information, see the section on airtightness testing in **chapter 7 Quality assurance on page 36**.

2.3. Moisture transport: damp building materials

In addition to the effects of diffusion and convection flow, moisture is also transported into the construction by wet materials used for the construction themselves. The amount of moisture incorporated in the building materials during construction is often underestimated. If the timber frame gets wet due to rain during construction the wood becomes wet. This moisture needs to dry out again to prevent mould from forming, see Fig.17. The proportion of wood in walls is typically quite high in New Zealand. At a grid dimension of 400 mm, about 2.5 timber studs are needed per metre of wall, which corresponds to approx. 2.5 m of wood per m² of wall area. In addition, there are also the bottom plates, the trimming and frames for doors and windows as well as top plates. In total, it is safe to assume an additional length of 3 m of wood per m², amounting to 5.5 m per m². At a timber cross-section of 4" by 2" (90 mm x 45 mm), this results in a volume of 0.022 m³/m². At a density of 450 kg/m³ this amounts to approximately 10 kg of wood per m² of wall. In the building envelope, once it has been constructed, the wood dries out, i.e. its high initial moisture content is given off within the construction. If the wood has to dry by 10%, e.g. from 30% to 20%, then moisture amounting to 10% of the weight of the wood has to dry out. In the example given this is 10% of 10 kg of wood per m² of wall, which corresponds to 1 kg/m² of moisture, or 1 litre, see Tab. 2.

This means that for a typical New Zealand wall:

- At a timber drying rate of 1%, 100 g/m² of moisture is given off into the construction, and
- At a timber drying rate of 10%, this rises to 1,000 g/m².

This additional moisture needs to be able to escape to avoid structural damage. Thermal energy is required to dry the wood out.

In the summer, this thermal energy comes from outside. In typical New Zealand buildings, however, there is a risk of condensation forming on the cooler internal parts of the wall. In the

winter the thermal energy comes from inside and there is a risk of condensation forming on the external surfaces of the building, which are now cold. It is thus necessary to ensure that the timber frame either stays as dry as possible (protection from the elements) or that the construction process allows time for the wood to dry out again. It is also necessary that the thermal insulation is not put in place until the wood has dried out.

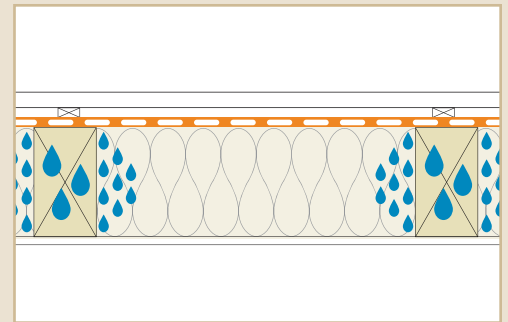
2.4. Moisture transport: thermal bridges

Thermal bridges cause localised cold spots within the construction. If the surface temperature drops below the saturation temperature of the air there is a risk of increased humidity. Although thermal bridges do not directly cause moisture within the construction, they contribute significantly to the growth of mould on the surfaces of building materials and to a reduction in energy efficiency, see Fig.18. For further information, see chapter 8, Thermal bridges, page 38.

2.5. Moisture transport: wrong construction sequence

Another potential source of elevated moisture transport is a poorly coordinated construction sequence. Normally the construction of a building is first sealed from the outside with a wall wrap or rigid wall cladding sheathing and then the insulation is put in place on the inside. If construction is poorly coordinated, it may take several weeks after that before the indoor airtightness membrane is installed. That is no problem in the summer, when the moisture travels from the outside to the inside. In the winter, however, this can lead to a significant increase in humidity, and thus to condensation, in the layer of the wall where the insulation is, especially in cooler regions such as in the South Island or Central Plateau. In the winter, the direction of diffusion is towards the outside and, due to the lack of a moisture control layer, the moisture can enter the insulated parts of the construction unhindered. This leads to the risk of condensation forming on the wall wrap, or rigid wall cladding sheathing like plywood or fibre cement boards, etc. depending on

Fig. 17.
Damp building materials



Building materials that are installed damp or that become wet or damp during construction have to be able to dry out without damaging the structure. The amount of moisture this involves is often underestimated.

Tab. 2.
Humidity of the wood in a wood stand wall/m²

If the timber dries by:

1% is	100 g/m ² water is released
10% is	1000 g/m ² water is released
20% is	2000 g/m ² water is released

Dimensions: 4" x 2" (90 mm x 45 mm)

Timber length/m²: Studs 2.5, dwangs 2.5, total = 5 m

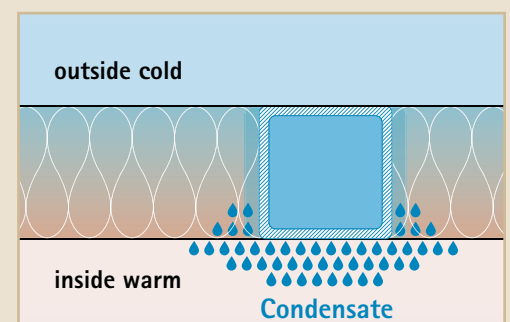
Timber weight/m² wall surface area:

90 mm x 45 mm and 5 m long = 0.022 m³

0.022 m³ x 450 kg/m³ = 10 kg/m² i.e.

1% drying = 100 g/m² water released

Fig. 18.
Damp due to thermal bridges

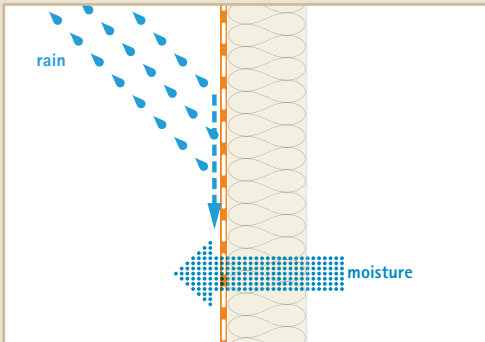


Thermal bridges contribute significantly to the growth of mould on the surfaces of building materials and to a reduction in energy efficiency.

NOTE:

The right sequence of construction provides protection against damage due to damp. In cold weather conditions the airtightness layer should be installed as soon as the thermal insulation has been put in place. If necessary, this should be done step by step.

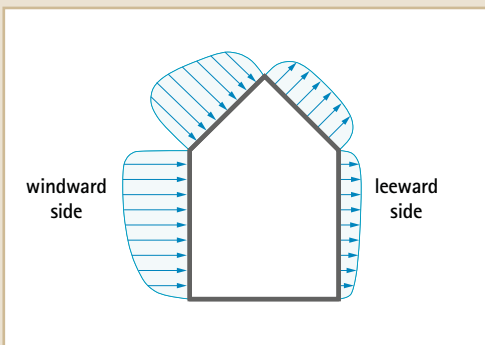
Fig. 19.
Damp due to driving rain



Ideal against water penetration from outside due to driving rain

- Façade sheeting that is very watertight, but simultaneously has a low diffusion resistance
- Watertight joints to all holes, penetrations and fittings such as windows

Fig. 20.
Wind effect



Wind effect on building: pressure and suction

the flow rate of the moisture and the diffusion tightness of the outer layers of building material. The moisture is usually not visible and goes unnoticed at the time when the airtightness layer or plasterboard is put in place. This results in a significantly higher risk of mould. When planning the construction sequence it is therefore necessary to make sure in cold climate conditions that the airtightness layer is sealed within a few days of putting the thermal insulation in place in order to protect the construction from additional moisture. Intelligent moisture management systems using pro clima INTELLO are the ideal solution.

2.6. Moisture transport: moisture due to driving rain

Moisture entering the building due to driving rain is commonly referred to as "leaky building syndrome". This is when driving rain penetrates the façade around fixtures such as windows and doors and enters the thermally insulated construction through the wall wrap from there.

In many parts of New Zealand, in Auckland and Wellington, for instance, there is a lot of driving rain. An example of a region with a low amount of driving rain is Christchurch. Poor sealing is one of the possible reasons for damage to wall constructions, especially in high-risk regions. For damage to the timber frame to occur, moisture has to penetrate the wall wrap from the outside. It is therefore worth selecting a wall wrap that is very watertight (water column/head > 10,000 mm), and is also diffusion-open (non-porous membrane with diffusion-active moisture transport), see Fig. 19.

Well protected constructions are rain-proof to the outside, while also being diffusion-open, and the same applies to joints. The use of impermeable adhesive tape, such as aluminium-coated bitumen tape, around joints poses a higher risk of condensation.

Both poor airtightness and thermal bridges can result in the same symptoms and effects as leaky building syndrome. Both can allow a considerable amount of moisture to enter

the construction from the inside and condense on the outside.

The moisture from the inside can be seen both outside and inside on all of the component layers, appearing as if it came from outside. This phenomenon is stronger on the leeward side of buildings due to the suction of the wind than on the windward side, allowing it to be distinguished from leaky house syndrome, see Fig. 20.

If there is damage in the region of the corners of the building and fixtures such as windows and doors, it is also advisable to consider the risk of moisture from inside as well as the risk of water entering through leaks in the façade. This can occur on the one hand due to the lack of airtightness and on the other hand due to thermal bridges caused by a complete lack of or insufficient thermal insulation in these areas. Both of these causes, poor airtightness and thermal bridges, result in a drop in temperature of the inner surfaces and thus promote the formation of condensation, both inside and outside. As described above, wind suction can cause condensation to form, especially on the downwind side (leeward side) by sucking air out of the building into the construction, even if the façade is not leaky.

When sealing fixtures in exterior walls such as doors and windows, the outer layer of flashing should be watertight. To prevent structural damage it would be advisable to connect wall wrap, plywood or cement boards with windows and doors by using TESCON EXTORA flashing tape to obtain a watertight layer that includes all fittings. In terms of achieving a permanently dry construction, the external sealing tape used should be diffusion-open, not impermeable. Diffusion-tight tape acts as a vapour barrier on the outside, which significantly increases the risk of condensation and thus of mould, especially for the moisture from inside, either by diffusion or convection flow.

Suitable products, such as diffusion-open adhesive tape, are not yet certified for sealing doors and windows in New Zealand. We hope the certification guidelines will be amended very soon, so externally diffusion-open

fitting details using adhesive tape will be adopted as standard for construction purposes.

2.7. Moisture transport: ventilation systems

Ventilation systems generally operate at a slight underpressure. In other words, the fan that sucks air out of the building moves slightly more air than the fan that blows air into the building. This is done to prevent the warm, moist indoor air (which could cause mould) penetrating the building's construction from within, then condensing there and causing mould to grow there.

A ventilation system that operates at overpressure is able to pump warm, moist indoor air through penetrations (gaps) into the construction. This can increase the moisture transport in the winter, resulting in structural damage.

The opposite could happen with ventilation systems that operate at an underpressure in the summer, with warm air from outdoors being sucked into the building envelope. It is then possible for warm, moist outdoor air to enter the building envelope from outside and condense on cooler layers of material on the inside, resulting in increased moisture levels within the construction and increasing the risk of mould growing.

So, for buildings with a ventilation system it is not only the airtightness from inside, but also the windtightness of the construction from outside that needs to be optimised, both in terms of planning and practically.

In terms of freedom from structural damage, ventilation systems that adapt to the environmental conditions are ideal. These are those which operate at an overpressure if it is outside warmer than inside (if the water vapour partial pressure outside is higher than inside) and operates at an underpressure if it is colder outside than inside (if the water vapour partial pressure outside is lower than inside).

2.8. Moisture transport: how vapour retarders work

In the winter, the direction of diffusion flow is towards the outside. This means that condensation may form on the cold surfaces of external parts of the building.

In the summer the direction of diffusion flow is reversed so it carries moisture inwards, which can result in condensation forming on the cooler surfaces of internal parts of the building, see Fig. 21.

A vapour retarder on the inside of the wall provides good protection against moisture penetrating the construction from inside in the winter. However in the summer there is a risk of condensation forming on the vapour retarder, if the moisture is carried from outside inwards, see Fig. 22.

A vapour retarder on the outside of the wall would provide good protection against moisture penetrating the construction from outside in the summer. However in the winter there would be a risk of condensation forming on the vapour retarder, if the moisture were to be carried from inside to outside, see Fig. 23.

The ideal solution is therefore to have a combination in the form of an intelligent airtightness membrane, which adjusts its diffusion resistance to the ambient conditions, see Fig. 24.

Convective moisture transport is much more critical than moisture transport due to diffusion flow. A complete lack of or insufficient airtightness membrane in thermally insulated timber and steel structures leads to very high moisture levels due to convection flow in the winter, usually resulting in structural damage [27].

Fig. 21. Diffusion flow in summer and winter

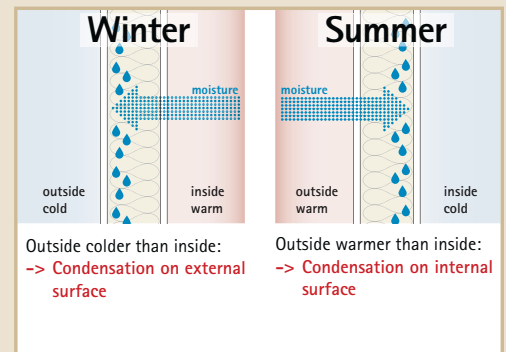


Fig. 22. The effects of a vapour retarder on the inside

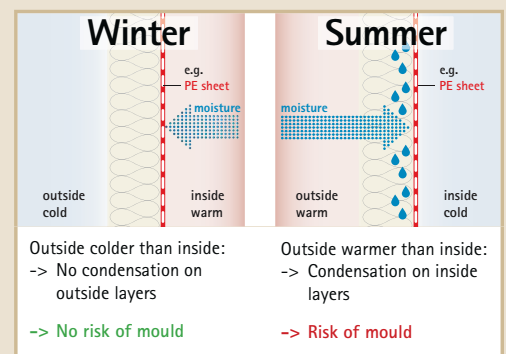
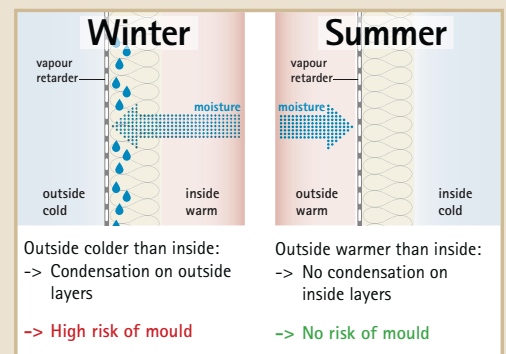
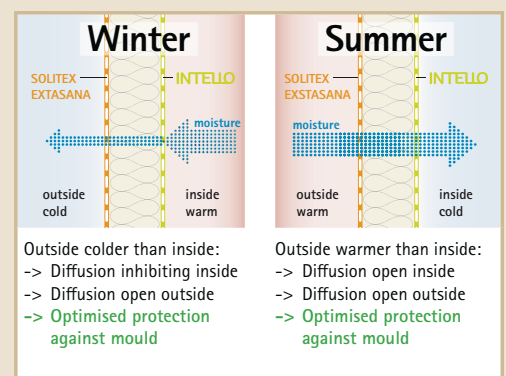


Fig. 23. The effects of a vapour retarder on the outside



WBP (wood based panel)

Fig. 24. The effects of intelligent moisture management

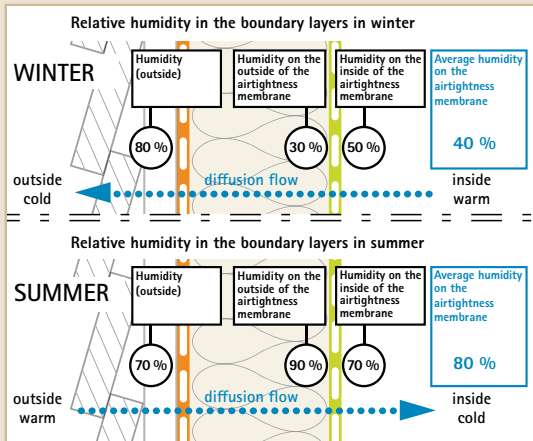


Moisture situation in the construction

The vapour diffusion flow is always from the warm side to the cold side. Thus:

In the winter: Condensation risk on the outside
 In the summer: Condensation risk on the inside

Fig. 25. Schematic diagram of the relative humidities surrounding the vapour retarder/air-tightness membrane in winter and summer



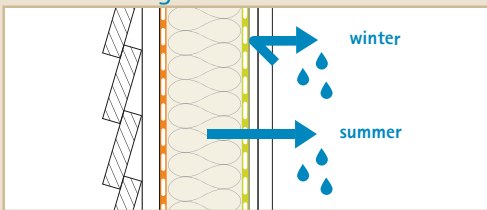
In the winter, the airtightness membrane is surrounded by low humidity:

=> The humidity-variable airtightness membrane is more diffusion-inhibiting

In the summer, the airtightness membrane is surrounded by high humidity:

=> The humidity-variable airtightness membrane is more diffusion-open

Fig. 26. The operating principle of humidity-variable airtightness membrane



Humidity-variable airtightness membrane is diffusion-inhibiting in the winter, protecting the construction from condensation, but is able to become diffusion-open in the summer, allowing the construction to dry out

Tab. 3. Diffusion flow through the in pro clima INTELLO humidity-variable airtightness membrane

Diffusion flow	Moisture flow rate in g/m ² per week	
	In the winter	In the summer
Direction of diffusion flow	Outwards, towards the roof underlay, wall wrap	Inwards, towards the airtightness membrane
INTELLO	7	560

2.9. Moisture transport: how humidity-variable airtightness membrane work

Moisture travels from the side of the wall with the higher vapour partial pressure to the side with the lower vapour partial pressure: to put it simply it flows from the warmer side to the colder side, in the winter from inside outwards and in the summer from the outside inwards.

The ideal solution is to have on the inside intelligent moisture management system with a higher diffusion resistance (diffusion-inhibiting) in the winter and with a lower diffusion resistance (diffusion-open) in the summer, see Fig. 25. This is achieved by pro clima INTELLO, an intelligent airtightness membrane with humidity-variable diffusion resistance. Its diffusion resistance varies automatically, depending on the ambient climate conditions, so it always has the ideal diffusion resistance. This function is governed by the average ambient humidity surrounding the membrane. As soon as the average ambient humidity surrounding the membrane rises, it becomes more diffusion-open, but if the average ambient humidity surrounding it drops, its diffusion resistance increases.

The average ambient humidity surrounding the membrane depends on the ambient environmental conditions.

- If it is warmer indoors than outdoors (winter), moisture travels from inside outwards, so the airtightness membrane is in a dry environment (low relative humidity indoors and in the adjoining building elements)
- If it is colder indoors than outdoors (summer), moisture travels from the outside inwards, so the airtightness membrane is in a damp environment (high relative humidity indoors and in the adjoining building elements)

The environment governs the relative humidity surrounding the membrane – and the relative humidity governs the diffusion resistance. This alternation not only takes place between summer and winter, but also between night and day. Measurements conducted by the

Fraunhofer Institute for Building Physics have shown the average ambient humidity of the airtightness membrane due to moisture transport from inside to outside is approximately 40% in timber and steel frame structures in wintery weather, see Fig. 25.

In summery weather, on the other hand, the relative humidity surrounding the membrane is higher due to the reversal of the direction of diffusion flow if there is moisture in the construction. This can result in summer condensation if vapour barriers and vapour retarders with constant diffusion resistance are used. This agrees with observations in New Zealand, although the effect is even more pronounced here due to the moister and warmer climate compared with the continental European climate.

The diffusion resistance of pro clima INTELLO, which is over 50 MNs/g in the winter, can drop to as low as 1.25 MNs/g in the summer, see Fig. 27.

Vapour barriers such as polyethylene (PE) sheet or aluminium foil, on the other hand, have a constant diffusion resistance. In other words, they have the same diffusion resistance in the winter (dry) as in the summer (damp), which means they can rapidly become moisture traps, see Fig. 28.

Since 1991, pro clima intelligent moisture management systems have proven themselves worldwide, with millions of m² having been installed. INTELLO is a membrane developed to cover an especially broad diffusion resistance range that is effective in every climate. Its humidity-variable diffusion resistance ranges from 1.25 MNs/g to over 50 MNs/g.

A humidity-variable membrane needs to have a diffusion profile that is also suitable for preventing structural damage in wet/humid rooms that have increased relative humidity levels. The increase is due to occupancy-generated moisture. The same applies to the higher initial moisture content in new buildings. The specifications are defined in the 60/10 and 79/7.5 rules, as described in chapter 9.5 on page 41.

2.10. Moisture transport: conclusion

- As discussed, it is impossible to provide 100% protection against moisture for any construction. It is therefore necessary to choose a construction and building materials that are able to cope with moisture. In principle, this means systems that are open to diffusion to the outside. The ideal solution is to use sealing systems that more or less automatically adjust to the environmental requirements.
- Use of vapour retarders with a constant diffusion resistance can cause condensation on the indoor surfaces of building materials in the summer. This results in a very high risk of mould due to the combination of moisture and temperature.
- Moisture due to diffusion can be allowed for. The intelligent moisture management membrane pro clima INTELLO provides optimum protection against structural damage and mould due to its variable diffusion resistance. This is diffusion-inhibiting in the winter, and open to diffusion in the summer.
- Convective moisture transport is much more critical than moisture transport due to diffusion. A complete lack of, or insufficient airtightness membrane in thermally insulated timber and steel frame construction leads to very high moisture levels due to convection in the winter. This usually resulting in structural damage, see Figs. 16. & 29.
- The wood used for the structure should be dry when the thermal insulation is installed and the airtightness layer put in place.
- Ventilation systems should operate at an overpressure if it is outside warmer than inside and should operate at an underpressure if it is colder outside than inside (regulation by the water vapour partial pressure differences)
- On the one hand, the objective is to plan and integrate an airtight and moisture-regulating layer in all constructions. On the other hand the objective is to increase the drying capacity of the building envelope. The potential freedom from structural damage should be as high as possible. Both of these requirements are fulfilled by pro clima's intelligent airtightness membrane INTELLO.

INTELLIGENT MOISTURE MANAGEMENT SYSTEM PROTECTION FORMULA:

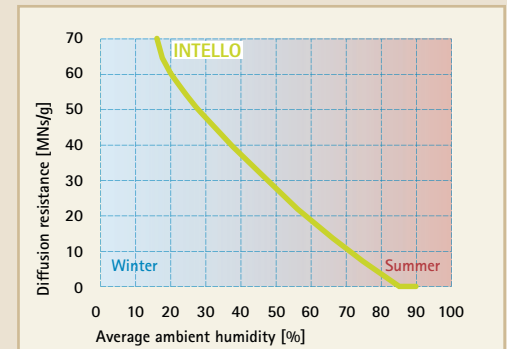
Drying capacity > moisture load = freedom from structural damage

Only if the moisture that enters the building envelope (plannable and unforeseen) is able to dry out quickly and completely can the construction remain free of structural damage.

Vapour diffusion resistance characteristics of the pro clima INTELLO airtightness membrane

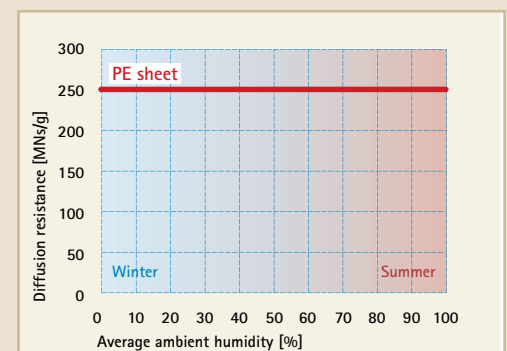
The greater the variability of the diffusion resistance between winter and summer, the greater the protection afforded by the airtightness membrane.

Fig. 27. Vapour diffusion resistance characteristics: pro clima INTELLO airtightness membrane



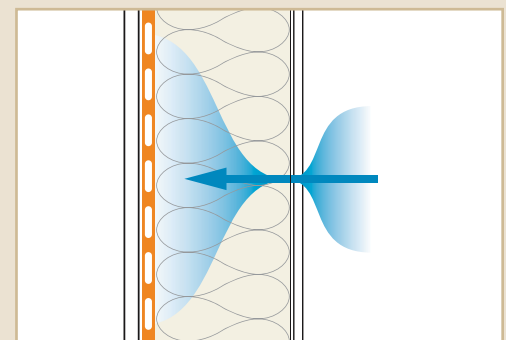
INTELLO: High humidity variability

Fig. 28. Vapour diffusion resistance characteristics: Vapour barrier PE sheet



PE sheet: No humidity variability

Fig. 29. Moisture transport due to convection through gaps in the inner lining

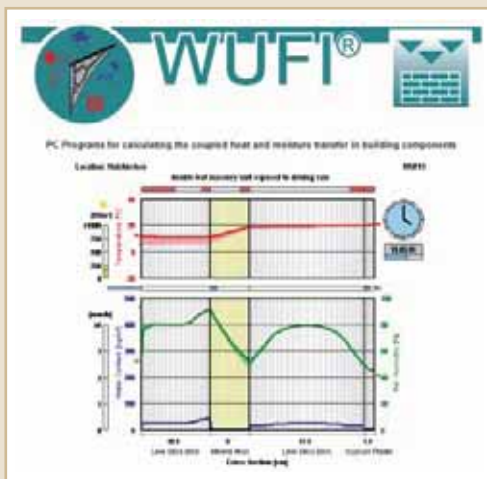


A significant amount of moisture can penetrate the building envelope by convection. This poses the risk of structural damage and mould if there is insufficient moisture compensation. The ideal solution is intelligent moisture management.

Fig. 30.
New Zealand



Fig. 31.
Calculation methods



Computer-assisted simulation programme for heat and humidity transport (dynamic)

WUFI (Fraunhofer Institute for Building Physics, Germany)

- Real climate data
- Inside and outside temperature
- Inside and outside humidity
- Light absorption
- Moisture storage capability
- Capillary action

(Data of one reference year at intervals of one hour)

3. Consideration of the building physics and moisture balance in building constructions

3.1. Calculation method

There are stationary and non-stationary (dynamic) methods for calculating the moisture load in building envelopes.

Stationary methods are highly simplified calculation methods that, firstly, only reflect the environmental conditions very imprecisely and, secondly, greatly simplify the building materials too. Stationary methods are useful for obtaining a rough assessment of constructions, but are not suitable for evaluating the real-life environmental effects and moisture transport processes within building envelopes.

Non-stationary methods are capable of analysing moisture transport processes within building envelopes realistically. Material properties such as capillary diffusion capacity and sorption behaviour are only taken into account by such methods, which calculate the heat and moisture transport on the basis of real environmental climate conditions.

3.1.1. Stationary calculation method in accordance with ISO 13788

The ISO 13788 standard specifies the method used for calculating the amount of condensation in constructions. The year is simplified by being broken down into two blocks, one for winter and one for summer. The meteorological data for each of the blocks is constant, which is why this method is described as stationary, as it doesn't take any real environmental conditions into consideration. The results are merely a rough approximation and can on no account be taken as a realistic representation of the actual moisture transport processes within a construction [28].

3.1.2. Non-stationary (dynamic) method

Non-stationary computer programmes can be used to simulate moisture

movements realistically for a specific construction and on the basis of the actual environmental conditions.

Well-known computer programmes include Delphin, developed by the Institute for Building Climatology in Dresden (Germany) and WUFI pro [29] developed by the Fraunhofer Institute for Building Physics in Holzkirchen (Germany), see Fig. 31.

Both of these programmes take the coupled heat and moisture transport of multi-layer building materials under natural environmental conditions into consideration. Non-stationary methods take meteorological data into consideration to calculate the processes occurring within the building materials. This means the calculation relates to the actual temperature and humidity, sunlight absorption, wind and cooling due to evaporation. In addition to this, the properties of the building materials are considered in detail and factors such as absorption and capillary action are also included in the calculation. The simulation calculations are validated several times: the results of the calculation are compared to actual building investigations and confirmed.

The meteorological data used by the programmes comes from weather stations around the world. For each calculation it is possible for the programme to use the data for a certain year and weather station as hourly values. The coverage provided by this data in New Zealand is almost 100%.

To calculate a simulation, the building component is entered into the programme together with its layer sequence. Then, the heat and moisture movements within the material are simulated in 8760 individual steps per year (24 hours x 365 days = 8760). The results of the simulation show whether moisture accumulates or reduces: whether the total moisture content of the structure over the period under consideration rises or whether it stays dry.

It is also possible to determine the moisture content of each individual layer of material. The moisture level at the boundary layers of a material

indicates whether there may be a risk of mould and the moisture level within each layer indicated the level of risk for the building envelope as a whole.

The calculations in this study were performed using the simulation programme WUFI 4.0 developed by the Fraunhofer Institute for Building Physics in Holzkirchen, Germany. The New Zealand partner for WUFI from the Fraunhofer Institute for Building Physics is BRANZ.

WUFI simulations give a realistic impression of the building physics for a wide variety of different constructions for all climatic regions.

3.2. Protecting building materials: calculation of the potential freedom from structural damage due to moisture

The potential freedom from structural damage describes how well protected a construction is against the effects of moisture i.e. how much unforeseen moisture is able to penetrate the building envelope without causing structural damage.

To calculate this potential, the simulation begins by adding between two and four litres per square meter (l/m^2) of moisture to the building component. The speed at which it dries and the amount of moisture describe the potential freedom from structural damage, i.e. the amount of water that is able to dry out within the first year of the simulation and thus, in turn, the amount of unforeseen moisture that could penetrate the building envelope without damaging it, see Fig. 32.

An outward-facing construction is chosen to determine the potential freedom from structural damage in the roof. The drying speed of the outward-facing impermeable constructions describes the performance of the pro clima INTELLO intelligent moisture management system.

For wall constructions, the simulation uses exemplary construction materials with a high computational initial moisture content. The drying capacity is evaluated and assessed within each individual layer of the building component in order to determine which areas are most critical.

The drying capacity of the construction, which is compromised by unforeseen penetrations, should be greater than 250 g/m^2 [30] [31].

3.3. Protecting building materials: consideration of the moisture behaviour of layers of building materials and their surfaces

In the calculation below, the simulation begins with the normal level of moisture found in buildings as the initial moisture content. To be able to represent and assess the moisture transport and content well in each layer of material it is possible to divide a layer up into a number of sub-layers. Moisture on the surface indicates there is a risk of mould. Moisture in the central layer indicates there is a risk of structural damage.

This method of calculation helps make it easier to understand the flow of moisture through the constructions and the different building materials in the various different environmental conditions.

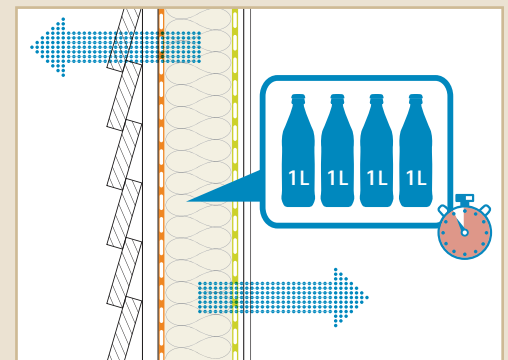
This study concentrates on this method, to reach conclusions about the moisture content of building materials in the New Zealand climate.

NOTE:

The potential freedom from structural damage describes how well protected a building envelope is against the effects of moisture.
How much unforeseen moisture is able to penetrate the building envelope without causing structural damage: the faster a construction can dry out, the better protected it is and the higher its potential freedom from structural damage.

Fig. 32.
Simulation

Potential freedom from structural damage



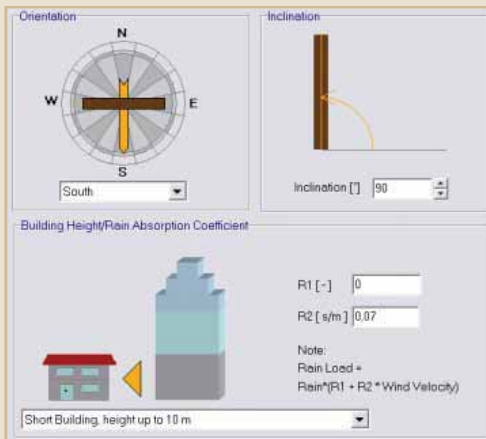
Between two and four litres of water are added into the construction.

The faster it can dry out (inwards and outwards), the higher its potential freedom from structural damage.

WUFI seminars and training courses

WUFI is a software tool for simulation and calculation of heat and moisture flows within constructions based on the actual climate conditions and the individual orientation of buildings. The program will determine how high the humidity levels and the risk of mould and structural damage will be within constructions. WUFI was designed to international standards, is used worldwide and also takes into account the climate conditions of New Zealand. WUFI was developed by the Fraunhofer Institute for Building Physics (IBP), Germany. The IBP offers seminars at various locations that include the understanding of building physics principles and an introduction to the use of the software. From spring 2012 seminars will be offered in New Zealand and Australia. For information on the WUFI seminars please contact us.

Fig. 33
Calculation settings



Unfavourable conditions for walls:

Wall orientation:

South -> Low sun absorption

Colour of façade:

White -> Low sun absorption

4. Walls

4.1. Boundary conditions and construction details

To evaluate how well protected a building component is, it is necessary to consider worst-case scenarios. The worst-case scenario is critical for decisions about the overall protection of the building envelope. The conditions chosen are therefore the worst possible:

- The construction detail studied is facing south, as less solar energy is absorbed on this side
- The colour of the façade is defined as "normal/light" (which has a colder surface temperature than dark colours)
- For walls, the wall cladding is constructed with a cavity without an air vent at the top only as drainage cavity (in accordance with the guidelines published by the Department of Building and Housing in the booklet *Constructing cavities for wall claddings*)

Detached and semi-detached houses often have walls that are clad with cladding materials such as wood, cement or cement-bonded boards with plaster or weatherproofing, façades made of brick veneer, or metal. Two types of cladding were chosen for this study:

- Cement-bonded boards with lime-cement plaster, and
- Wood cladding.

At this stage, material-specific figures are not yet available for all building materials in use in New Zealand. The following material data was used for the non-stationary calculation using the simulation programme WUFI:

Basic values

- Bulk density
- Porosity
- Specific heat capacity
- Thermal conductivity
- Water vapour diffusion resistance factor

Hygic Expressions

- Moisture storage function
- Liquid transport coefficient - suction
- Liquid transport coefficient - redistribution
- Thermal conductivity, moisture-dependent
- Water vapour diffusion resistance factor, humidity-dependent

The material data for INTELLO are integrated in WUFI internationally. The missing material data for New Zealand required for the simulation was obtained from material data sets provided by the Fraunhofer Institute in Germany and American institutes.

- Colour of the façade: normal white
- (short-wave radiation absorptivity = 0.4)
- Orientation: south
- Period covered by the calculation: three years

4.1.1. Construction details of the wall

- Wall cladding
 - Cement boards with regular lime stucco
 - Wood cladding
- Layer of air (drainage cavity)
- Diffusion-open vapour permeable wall lining membrane, e.g. SOLITEX EXTASANA
- Thermal insulation 90 mm of mineral wool
- Airtightness
 - No airtightness
 - With INTELLO airtightness membrane
- Cavity 10 mm
- 10 mm of gypsum plasterboard

4.1.2. Calculation with two different façades

A. (see Fig. 34.)

- 6 mm cement boards (moisture content, dry = 60 kg/m³)
- 20 mm regular lime stucco with driving rain load (rain water absorption factor = 0.7)

B. (see Fig. 35.)

- Wood cladding 24 mm (divided into 5 mm inner layer and 19 mm outer layer for the consideration of mould), without driving rain load (assuming water-repellent, diffusion-open paint is used)

4.1.3. Environmental conditions and locations

Outdoor climate

- a. Auckland
- b. Wellington
- c. Christchurch
- d. Queenstown

Indoor climate:

- In the north:
Temperature 20°C +/- 2°C
- In the south:
Temperature 18°C +/- 2°C
- Relative humidity: "High moisture load" = 55% +/- 5%

4.1.4. Layers critical to building physics with the risk of condensation

In a wintery environment the layers, or building components on the outside of the building pose a problem, from a building physics point of view. This is especially so if they are less permeable than the inner layers, so that they impede the flow of moisture. If there is only plasterboard on the inside and/or there are (also) air penetrations, both the wall wrap as well as the wall cladding, which is separated from the structure by the drainage cavity, act as diffusion-inhibiting layers. In some cases, this may result in condensation forming or water collecting, resulting in a risk of mould growth.

When analysing the moisture situation, we distinguish between surface moisture and material moisture. High material moisture levels can lead to structural damage. High surface moisture levels can lead to mould on the material surfaces.

Consideration is particularly given to layers of material that do not have an air cavity such as wall wraps. If the diffusion resistance of the wall wrap is higher than 0.75 MNs/g ($s_d > 0.5$ m) this can be too high in the winter. Wall wrap with a diffusion resistance of 2.5 MNs/g rapidly becomes a condensation trap in such constructions, as we will see later.

To analyse the surface moisture, the moisture content of the boundary layers is determined. A boundary layer thickness of 2 – 5 mm has proven itself, as it both gives an impression of the surface moisture as well as allowing an estimate of the total moisture to be made. It can thus be used as an indicator for the risk of mould.

In the summer, the main risk is internal condensation, also known as summer condensation. Against this a windtight, but diffusion-open wall wrap such as pro clima SOLITEX EXTASANA provides very good protection.

This study analyses the moisture content of the following critical layers of building material:

- The outer 5 mm of the mineral wool insulation
- The inner 5 mm of the wood cladding
- The moisture in the 6 mm thick cement-bonded board.

Comparing:

- Without moisture management,
- With the intelligent moisture management membrane, INTELLO.

Fig. 34.
Wall construction A

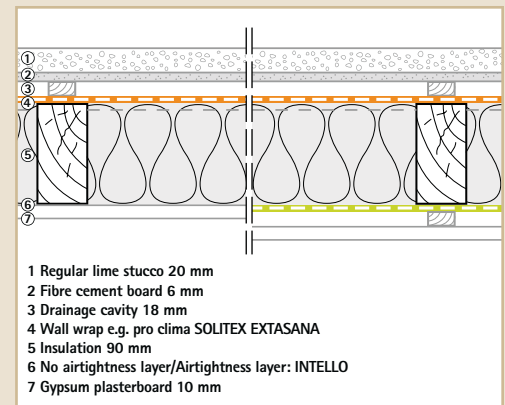
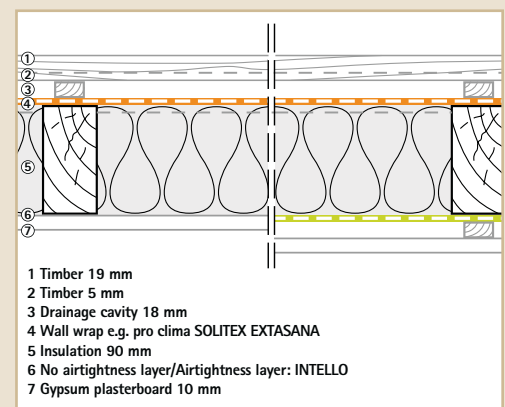


Fig. 35.
Wall construction B



Evaluation of the following results:

The calculations are to be understood as comparisons of same layer construction details and material to demonstrate the performance of the intelligent moisture management. The moisture situation in plaster, fibre cement boards and thermal insulation depends essentially on the water uptake, the hydrophobic or watertightness of the plaster. Specific calculations in individual cases are possible if the building physics data of individual products are known.

4.2.1. Calculation of the moisture behaviour of layers of building materials and surfaces in Auckland

Climate in the Auckland area:

Subtropical: Long, warm, humid summer, humid winter

Maximum daytime temperatures
 Summer: 24 - 30°C. Winter: 10 - 15°C
 Minimum temperature at night: 2°C

Average annual precipitation: 1226 mm.
 Driving rain load: 600 mm/a.
 Prevailing winds: from the southwest

Fig. 36. Temperature and relative humidity

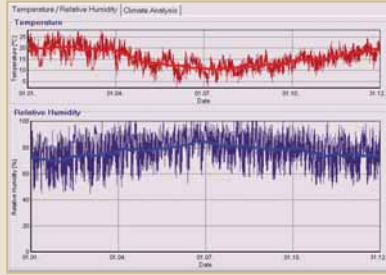
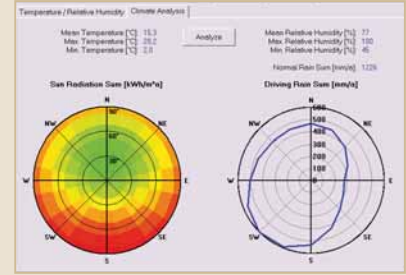
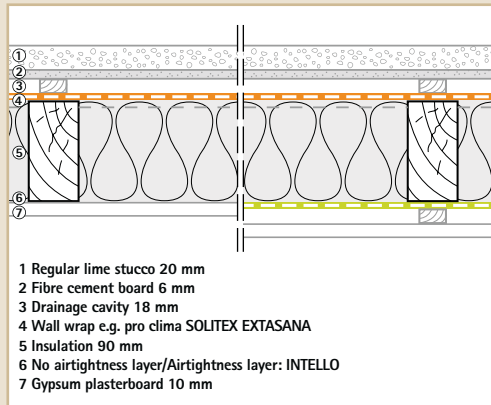


Fig. 37. Solar Radiation and Driving Rain

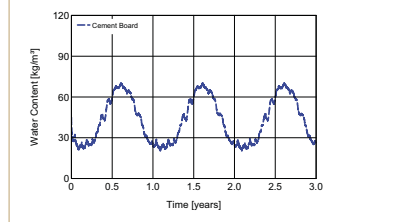


4.2.2. Cement board – regular lime-stucco façade



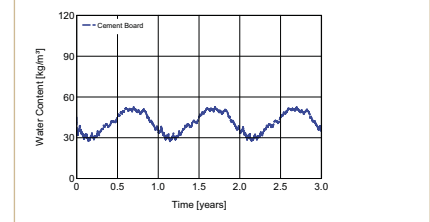
Moisture content of cement-bonded boards

Without moisture management:



→ Moisture content of the cement-bonded boards rose to 70 kg/m³

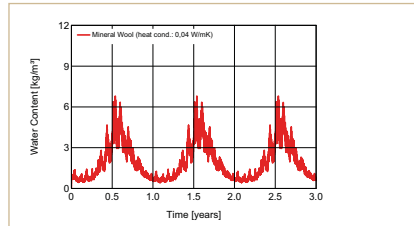
With INTELLO moisture management:



→ Insignificant increase in the moisture content of the cement-bonded boards

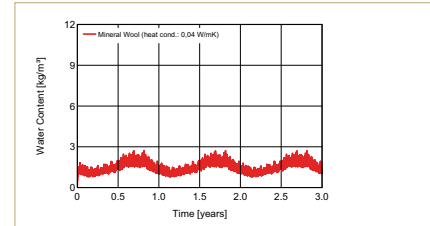
Moisture content of the 5 mm outer layer of thermal insulation

Without moisture management:



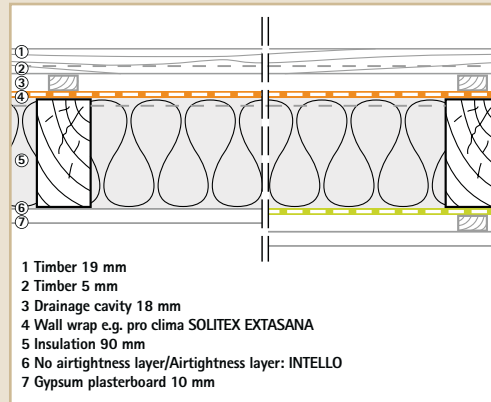
→ Moisture content of the 5 mm outer layer of thermal insulation rose to 6.5 kg/m³

With INTELLO moisture management:



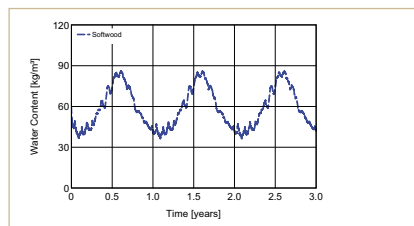
→ Insignificant increase in the moisture content of the 5 mm outer layer of thermal insulation

4.2.3. Wood cladding



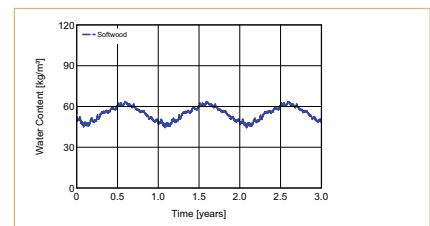
Moisture content of the 5 mm inner layer of wooden cladding

Without moisture management:



→ Moisture content of the 5 mm inner layer of wooden cladding rose to 80 kg/m³

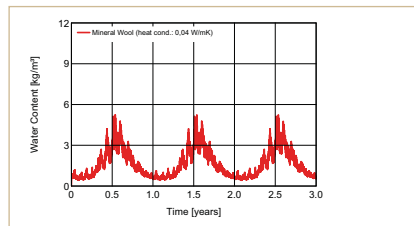
With INTELLO moisture management:



→ Insignificant increase in the moisture content of the 5 mm inner layer of wooden cladding

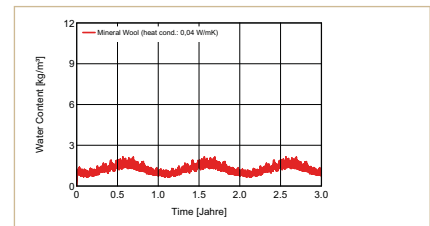
Moisture content of the 5 mm outer layer of thermal insulation

Without moisture management:



→ Moisture content of the 5 mm outer layer of thermal insulation rose to 5.5 kg/m³

With INTELLO moisture management:



→ Insignificant increase in the moisture content of the 5 mm outer layer of thermal insulation

Climate in the Wellington area:

Moderate climate zone - strong winds

Maximum daytime temperatures
 Summer: 20 - 27°C. Winter: 5 - 10°C
 Minimum temperature at night: 0°C

Average annual precipitation: 1017 mm.
 Driving rain load: 650 mm/a.
 Prevailing winds: east

Fig. 38. Temperature and relative humidity

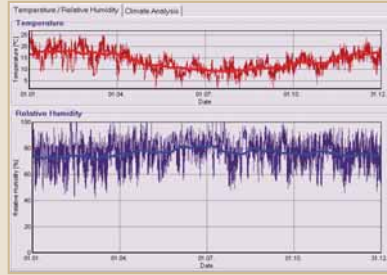
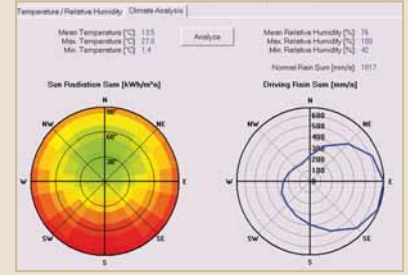
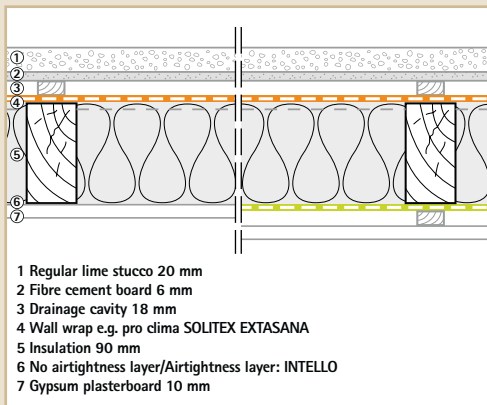


Fig. 39. Solar Radiation and Driving Rain

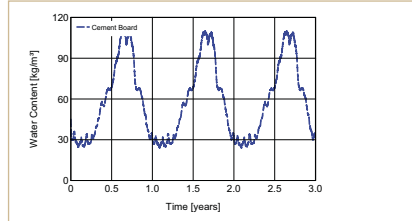


4.3.2. Cement board - regular lime-stucco façade



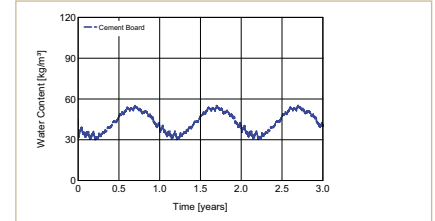
Moisture content of cement-bonded boards

Without moisture management:



→ Moisture content of the cement-bonded boards rose to 110 kg/m³

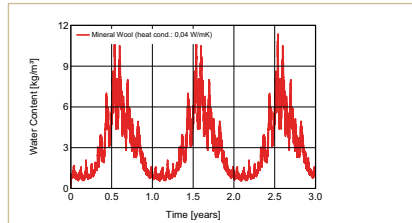
With INTELLO moisture management:



→ Insignificant increase in the moisture content of the cement-bonded boards

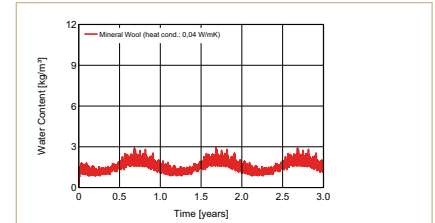
Moisture content of the 5 mm outer layer of thermal insulation

Without moisture management:



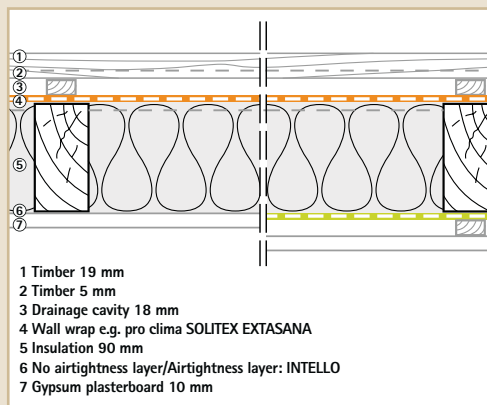
→ Moisture content of the 5 mm outer layer of thermal insulation rose to 11 kg/m³

With INTELLO moisture management:



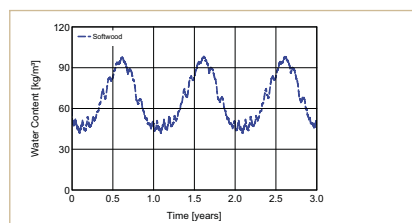
→ Insignificant increase in the moisture content of the 5 mm inner layer of thermal insulation

4.3.3. Wood cladding



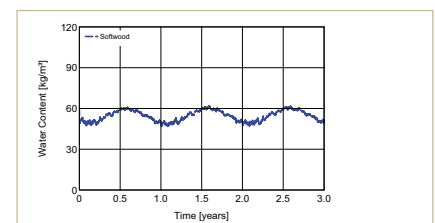
Moisture content of the 5 mm inner layer of wooden cladding

Without moisture management:



→ Moisture content of the 5 mm inner layer of wooden cladding rose to 100 kg/m²

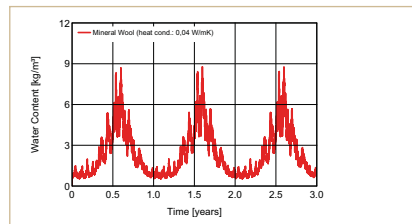
With INTELLO moisture management:



→ Insignificant increase in the moisture content of the 5 mm inner layer of wooden cladding

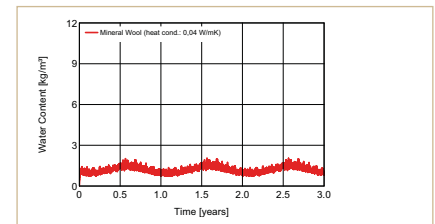
Moisture content of the 5 mm outer layer of thermal insulation

Without moisture management:



→ Moisture content of the 5 mm outer layer of thermal insulation rose to 9 kg/m³

With INTELLO moisture management:



→ Insignificant increase in the moisture content of the 5 mm outer layer of thermal insulation

4.4.1. Calculation of the moisture behaviour of layers of building materials and surfaces in Christchurch

Climate in the Christchurch area:

Moderate climate zone with gentle winds:
 Maximum daytime temperatures
 Summer: 15 - 25°C under certain conditions (e.g. foehn) up to 30°C. Winter: 5 - 10°C
 Minimum temperature at night: - 4°C
 Average annual precipitation: 613 mm.
 Driving rain load: 300 mm/a.
 Predominantly easterly.
 Snow possible in the winter.

Fig. 40. Temperature and relative humidity

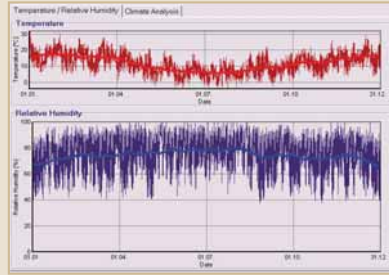
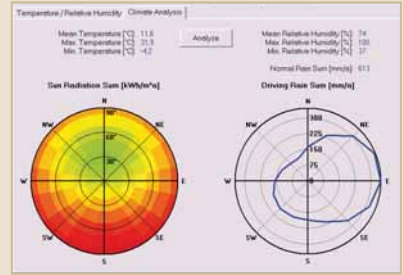
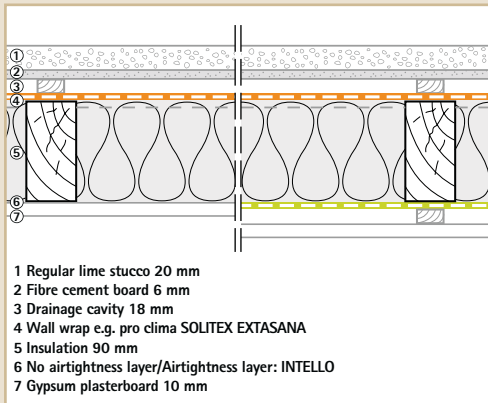


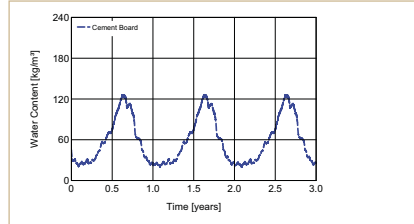
Fig. 41. Solar Radiation and Driving Rain



4.4.2. Cement board – regular lime-stucco façade

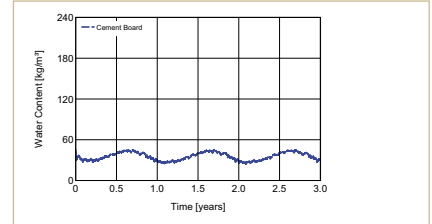


Moisture content of cement-bonded boards Without moisture management:



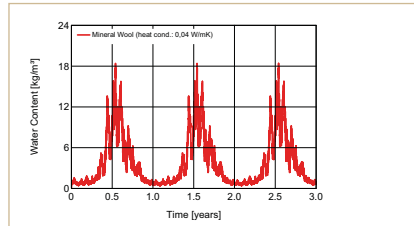
→ Moisture content of the cement-bonded boards rose to 120 kg/m³

With INTELLO moisture management:



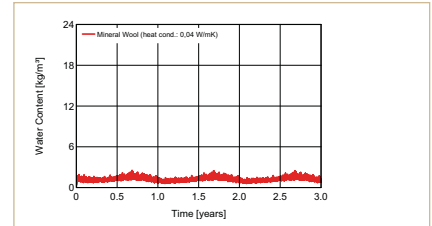
→ Insignificant increase in the moisture content of the cement-bonded boards

Moisture content of the 5 mm outer layer of thermal insulation Without moisture management:



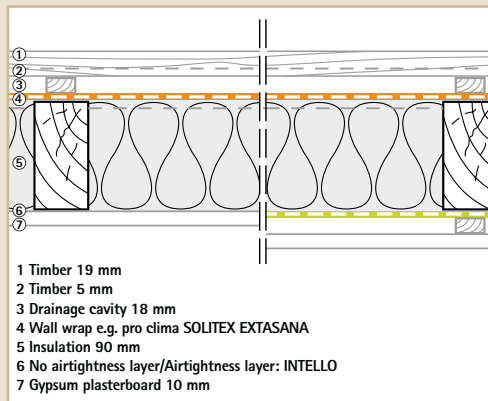
→ Moisture content of the 5 mm outer layer of thermal insulation rose to 18 kg/m³

With INTELLO moisture management:

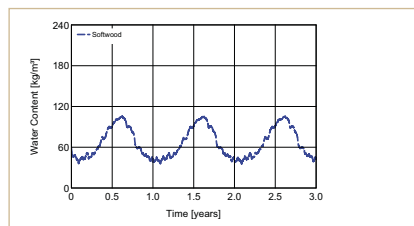


→ Insignificant increase in the moisture content of the 5 mm outer layer of thermal insulation

4.4.3. Wood cladding

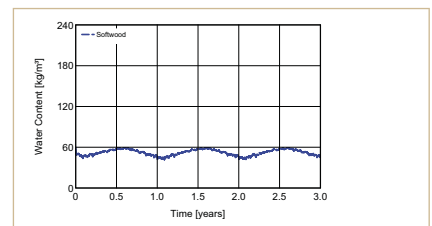


Moisture content of the 5 mm inner layer of wooden cladding Without moisture management:



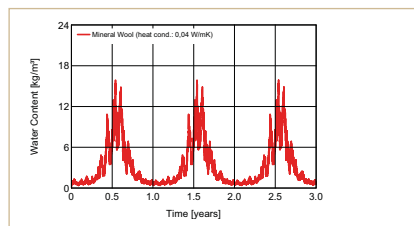
→ Moisture content of the 5 mm inner layer of wooden cladding rose to 110 kg/m³

With INTELLO moisture management:



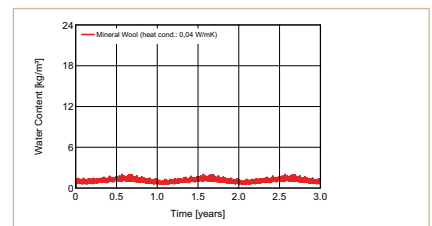
→ Insignificant increase in the moisture content of the 5 mm inner layer of wooden cladding

Moisture content of the 5 mm outer layer of thermal insulation Without moisture management:



→ Moisture content of the 5 mm outer layer of thermal insulation rose to 15 kg/m³

With INTELLO moisture management:



→ Insignificant increase in the moisture content of the 5 mm outer layer of thermal insulation

Climate in the Queenstown area:

Continental climate:

- Maximum daytime temperatures
- Summer: 20 - 25°C. Winter: 5 - 10°C
- Minimum temperature at night: - 6°C
- Average annual precipitation: 2171 mm.
- Driving rain load: From all directions, especially the southwest up to 450 mm/a

Fig. 42. Temperature and relative humidity

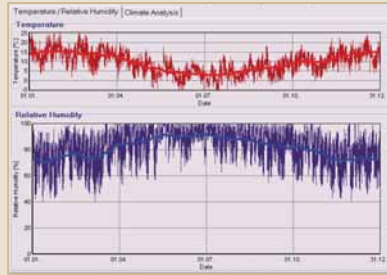
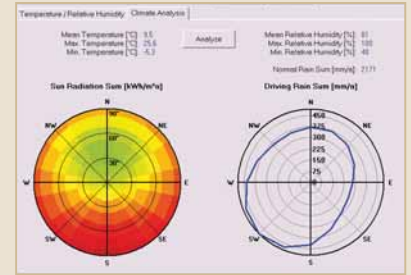
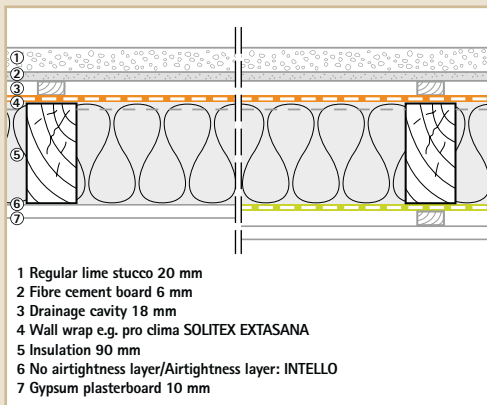


Fig. 43. Solar Radiation and Driving Rain

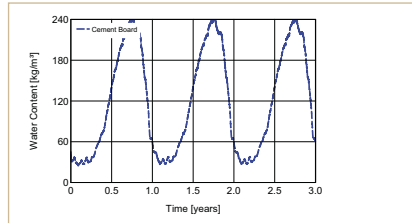


4.5.2. Cement board - regular lime-stucco façade



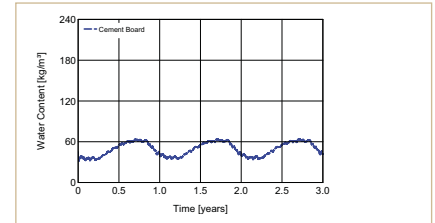
Moisture content of cement-bonded boards

Without moisture management:



→ Moisture content of the cement-bonded boards rose to 240 kg/m³

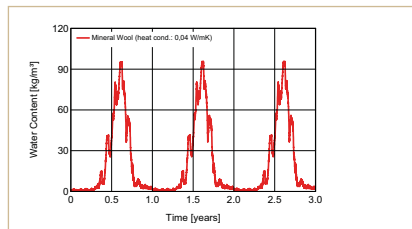
With INTELLO moisture management:



→ Insignificant increase in the moisture content of the cement-bonded boards

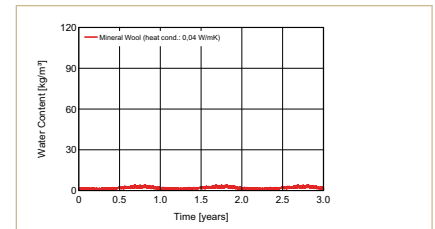
Moisture content of the 5 mm outer layer of thermal insulation

Without moisture management:



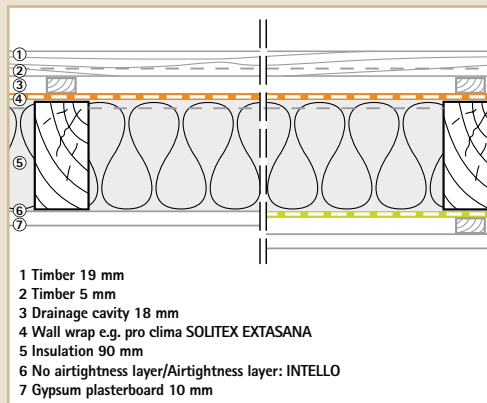
→ Moisture content of the 5 mm outer layer of thermal insulation rose to 90 kg/m³

With INTELLO moisture management:



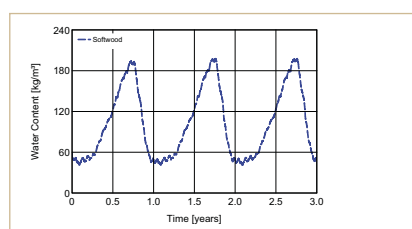
→ Insignificant increase in the moisture content of the 5 mm inner layer of thermal insulation

4.5.3. Wood cladding



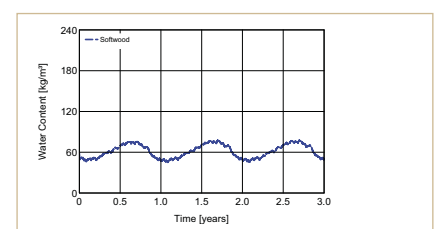
Moisture content of the 5 mm inner layer of wooden cladding

Without moisture management:



→ Moisture content of the 5 mm inner layer of wooden cladding rose to 190 kg/m²

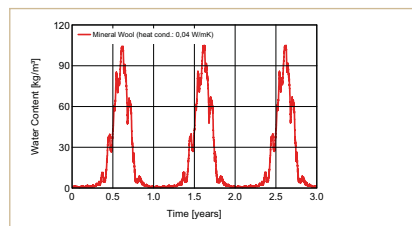
With INTELLO moisture management:



→ Insignificant increase in the moisture content of the 5 mm inner layer of wooden cladding

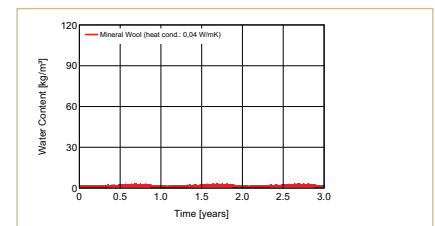
Moisture content of the 5 mm outer layer of thermal insulation

Without moisture management:



→ Moisture content of the 5 mm outer layer of thermal insulation rose to 100 kg/m³

With INTELLO moisture management:



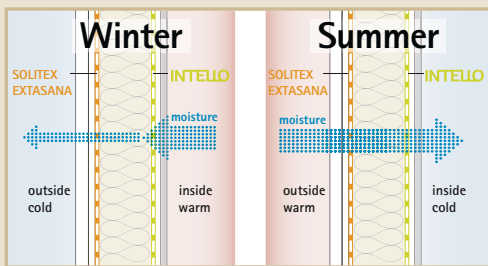
→ Insignificant increase in the moisture content of the 5 mm outer layer of thermal insulation

Fig. 44.
Mould in the building envelope



Without moisture management there is a risk of water condensing in the building envelope, and thus a risk of structural damage and mould.

Fig. 45.
Protection using intelligent moisture management



Due to the change in the diffusion resistance, intelligent airtightness systems can reduce the risk of structural damage and mould extremely effectively, both in the summer and in the winter.

4.6. Consideration of the results for walls, conclusion

- Building envelopes in New Zealand without internal moisture management cause significant moisture transport outwards in the winter. This increases the risk of condensation forming, either on the wall wrap in the construction or in the drainage cavity outside the structure.
 - Even if some of this condensation in the drainage cavity can drain out of the construction, a construction method that promotes the formation of condensation is not beneficial. This is because it can lead to structural damage in the long term. Elevated moisture levels within a construction lead to mould and rot.
 - The large amounts of moisture simulated using the WUFI programme developed by the Fraunhofer Institute (the New Zealand partner for WUFI from the Fraunhofer Institute for Building Physics is BRANZ), which uses real-life meteorological data. It has been validated several times in various locations around the world. It may not only shorten the life of the building, but, if mould grows, also pose a serious health hazard. This is especially so for individuals who (have to) spend long periods of time indoors.
 - Mould growth is very temperature-dependent. In the fridge, food goes mouldy far more slowly (the colder it is, the slower), than in the kitchen when it is warm and humid. Essentially, the warmer it is, the faster mould grows.
 - For this reason, condensation in the summer on the inside of the thermal insulation is much more serious, as far as the risk of mould is concerned. It is more of a health risk than in the winter on the outside of the thermal insulation.
- The calculations performed with the intelligent moisture management membrane pro clima INTELLO show that the amount of moisture in the construction is far lower, in the winter and in the summer. Due to the change in the diffusion resistance of INTELLO (humidity variability) in response to the environmental conditions, the risk of mould is reduced extremely effectively. Intelligent moisture management membranes can, if installed to create an airtight seal, provide permanent protection for constructions against moisture resulting from diffusion and convection from the inside.
 - The calculations are to be understood as comparisons of same layer construction details and material to demonstrate the performance of the intelligent moisture management. The moisture situation in plaster, fibre cement boards and thermal insulation depends essentially on the water uptake, the hydrophobic or watertightness of the plaster. Specific calculations in individual cases are possible if the building physics data of individual products are known.

5. Comparison of various types of wall wraps with regard to vapour permeability, rain-tightness and windtightness

5.1. Vapour diffusion permeability

The physical parameters of the cladding, the external condensation (wood cladding, cement-bonded boards, metal, masonry, etc.) are hard to influence.

There are numerous differences and options in terms of the physical parameters and properties of wall wraps. Wall wraps should have the following properties:

- Low diffusion resistance
- Water-tightness
- Wind-tightness

For the building physics of the thermal insulation system, diffusion resistance is most important, after the water-tightness. This is especially so if the construction does not have a moisture management system or if it is not airtight: i.e. if a significant flow of moisture through the building envelope is to be expected.

The higher the diffusion resistance on the outside of the building envelope, the lower the amount of moisture that is transported out of the construction. The risk of lasting structural damage due to condensation and a reduction in the healthiness of the building increases significantly.

The diffusion resistance of wall wraps should be less than 0.75 MNs/g. The effect of the diffusion resistance on the moisture situation is studied using the WUFI simulations for the locations described above on constructions with wood cladding.

A comparison is made between the moisture content of the outer 5 mm layer of thermal insulation with 2 different types of wall wrap:

- Diffusion resistance 0.75 MNs/g
- Diffusion resistance 2.50 MNs/g
- Without moisture management
- With moisture management.

The graphs 5.1.1. – 5.1.4. show very impressively that a higher diffusion resistance of the wall wrap significantly increases the amount of water that condenses within the construction. However the intelligent moisture management provided by INTELLO is capable of meeting the challenge of compensating for this in every climatic region in New Zealand. Building envelopes stay safe and dry, even if a impermeable wall wrap is used.

The same also applies to diffusion barriers, in particular adhesive tape with bitumen or butyl rubber. The intelligent moisture management system is even capable of compensating for such diffusion barriers on the outside.

A construction that is more diffusion open from the inside towards the outside allows for a greater drying capacity of the construction. The result is dry structural timber that will have a naturally higher protection against insects and fungi.

In 1996 Germany introduced the DIN 68800-2 standard (Protection of timber – part 2: Preventive constructional measures in buildings).

The standard states that with a MVTR of less than 1 MNs/g no chemical timber treatment is needed if the construction is sealed airtight on the inside and windtight from the outside. A construction design based on the DIN 68800-2 standard with a high drying capacity will provide adequate protection against insects and fungi.

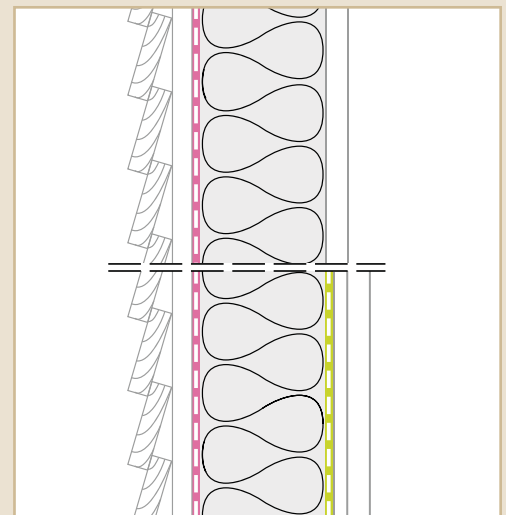
In New Zealand the reduction or even elimination of timber treatments may not be thinkable at this time but perhaps in the future it will be considered as the solution for a more healthy construction and less environmental impact.

NOTE:

The diffusion resistance of the wall wrap has a significant influence on how well the construction is protected against damage. The more diffusion-open the membrane, the better the protection it provides the construction. Less permeable membrane needs intelligent moisture management on the inside (see the calculations on page 30/31)

Comparison of various types of wall wraps

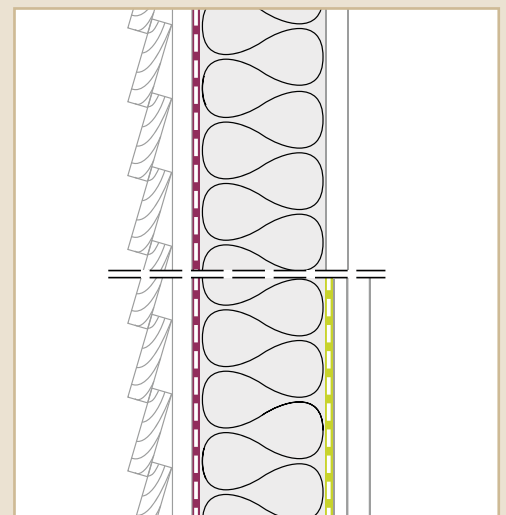
Fig. 46.
Setup A



External wall wrap 0.75 MNs/g
(low vapour resistance)

Inside without/with intelligent moisture management

Fig. 47.
Setup B



External wall wrap 2.50 MNs/g
(medium vapour resistance)

Inside without/with intelligent moisture management

RESULTS FOR AUCKLAND:

Without moisture management:

Critical levels of dampening of the adjacent layer of thermal insulation on the wall wrap with a diffusion resistance of:

- 0.75 MNs/g up to 5 kg water/m³
- 2.50 MNs/g up to 8 kg water/m³

With intelligent moisture management:

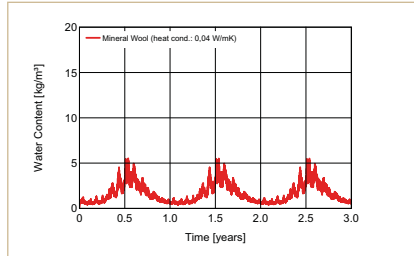
Even with relatively impermeable membrane (2.50 MNs/g) the moisture remains below the critical level.

5.1.1. Results for Auckland

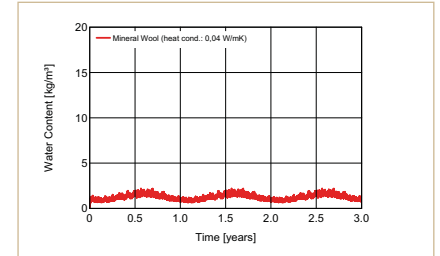
Moisture content of the 5 mm outer layer of thermal insulation

Diffusion resistance of the wall wrap: 0.75 MNs/g

Without moisture management:

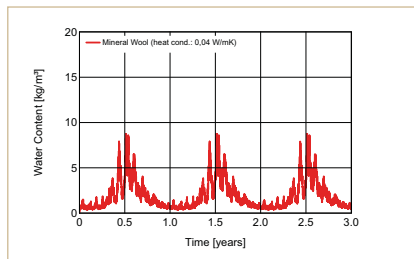


With INTELLO moisture management:

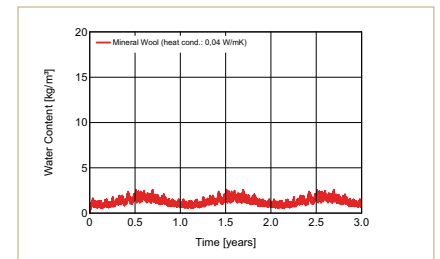


Diffusion resistance of the wall wrap: 2.50 MNs/g

Without moisture management:



With INTELLO moisture management:



RESULTS FOR WELLINGTON:

Without moisture management:

Critical levels of dampening of the adjacent layer of thermal insulation on the wall wrap with a diffusion resistance of:

- 0.75 MNs/g up to 9 kg water/m³
- 2.50 MNs/g up to 18 kg water/m³

With intelligent moisture management:

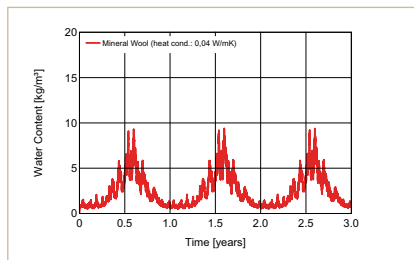
Even with relatively impermeable membrane (2.50 MNs/g) the moisture remains below the critical level.

5.1.2. Results for Wellington

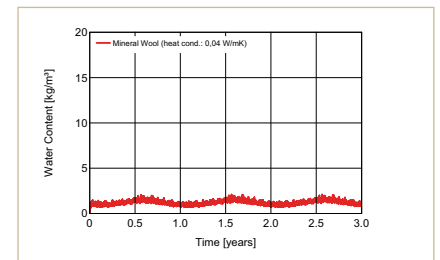
Moisture content of the 5 mm outer layer of thermal insulation

Diffusion resistance of the wall wrap: 0.75 MNs/g

Without moisture management:

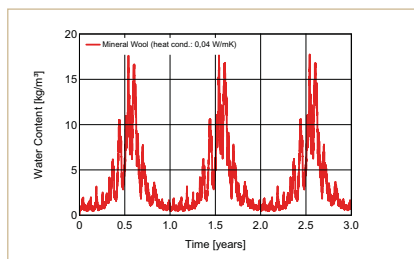


With INTELLO moisture management:

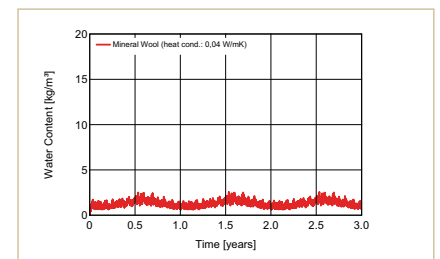


Diffusion resistance of the wall wrap: 2.50 MNs/g

Without moisture management:



With INTELLO moisture management:



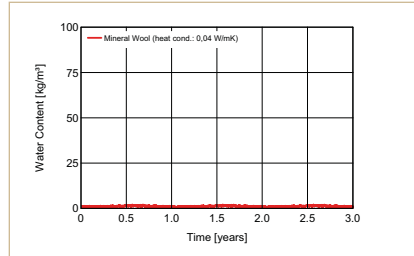
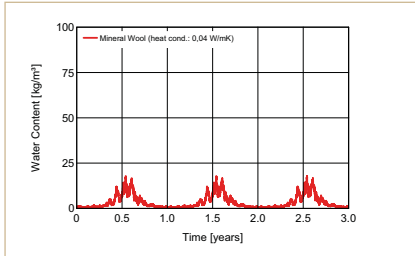
5.1.3. Results for Christchurch

Moisture content of the 5 mm outer layer of thermal insulation

Diffusion resistance of the wall wrap: 0.75 MNs/g

Without moisture management:

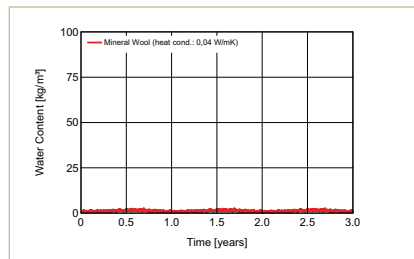
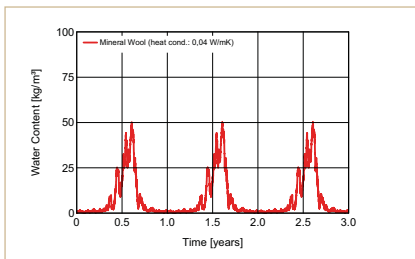
With INTELLO moisture management:



Diffusion resistance of the wall wrap: 2.50 MNs/g

Without moisture management:

With INTELLO moisture management:



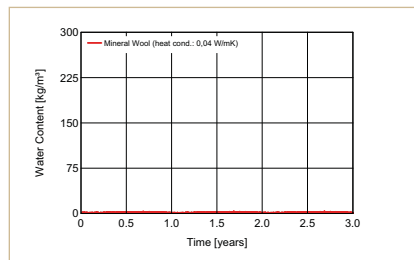
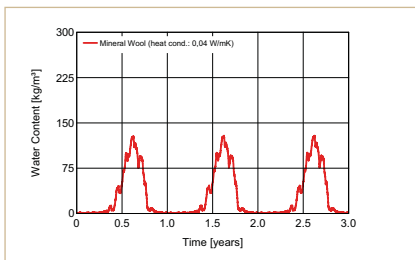
5.1.4. Results for Queenstown

Moisture content of the 5 mm outer layer of thermal insulation

Diffusion resistance of the wall wrap: 0.75 MNs/g

Without moisture management:

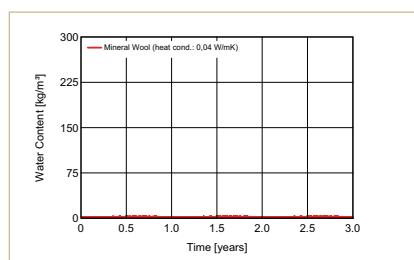
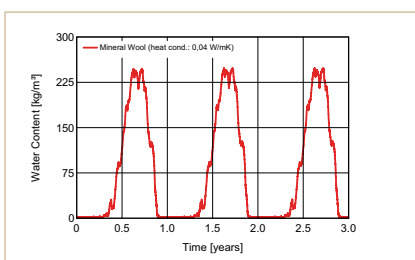
With INTELLO moisture management:



Diffusion resistance of the wall wrap: 2.50 MNs/g

Without moisture management:

With INTELLO moisture management:



RESULTS FOR CHRISTCHURCH:

Without moisture management:

Critical levels of dampening of the adjacent layer of thermal insulation on the wall wrap with a diffusion resistance of:

- 0.75 MNs/g up to 15 kg water/m³
- 2.50 MNs/g up to 50 kg water/m³

With intelligent moisture management:

Even with relatively impermeable membrane (2.50 MNs/g) the moisture remains below the critical level.

RESULTS FOR QUEENSTOWN:

Without moisture management:

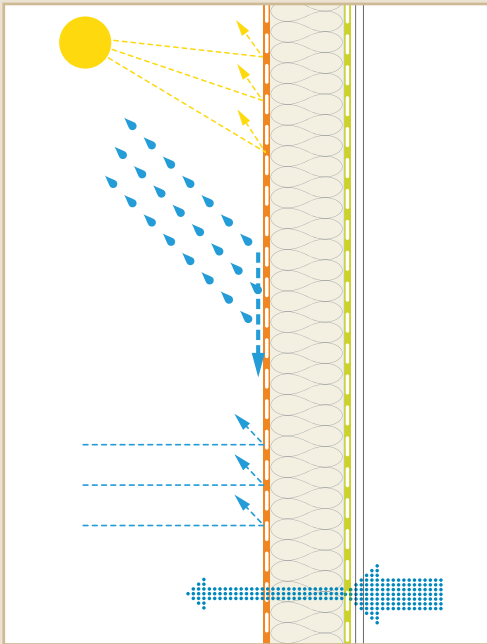
Critical levels of dampening of the adjacent layer of thermal insulation on the wall wrap with a diffusion resistance of:

- 0.75 MNs/g up to 110 kg water/m³
- 2.50 MNs/g up to 250 kg water/m³

With intelligent moisture management:

Even with relatively impermeable membrane (2.50 MNs/g) the moisture remains below the critical level.

Fig. 48.
Requirements for wall wrap



Wall wrap needs to protect the construction against the elements. It should, therefore, be:

- Impermeable to rain, wind and snow
- While at the same time being very vapour permeable and open to diffusion in order to allow unforeseen moisture that penetrates the construction to dry out again quickly
- Prerequisites for long-lasting effectiveness are high thermal stability and UV resistance

Fig. 49.
Condensation on the roof underlay due to poor airtightness



Photo: Paula Hugens, GREEN Being Ltd

In Queenstown: Frozen condensation on the inside of the roof lining membrane, caused by moisture from the rooms below that entered the attic space through penetrations in the ceiling (e.g. around light fittings) and then condensed on the cold roof underlay.

5.2. Raintightness

It is not just the material used that dictates for how well sealed the building envelope is, but also the design details. Water has to be able to drain off. If there are horizontal roof battens without counter battening, water collects on the batten when it rains, if no roof cladding has yet been laid. In addition to this, this critical region is also where the nails are, which act like a wick for water, especially for standing water. It is recommended that you use counter battening, i.e. battens along the rafters, if the roof needs to be watertight while open to the elements.

The rainproofing provided by the wall wrap protects the construction from the elements on the outside. While the construction is open to the elements it should provide protection against driving rain. Once the building is in use it should provide protection against any water that manages to penetrate the cladding due to driving rain or wind. This layer is effectively the second line of defence for the construction. The more watertight the membrane, the better protected the building envelope is against the effects of moisture from outside. The membrane's vapour permeability must not, however, be reduced by its watertightness.

The watertightness is tested in various ways. The most common, internationally, is measurement of the maximum water column according to EN 20811. The pressure exerted on the membrane by a column of water simulates the pressure exerted by raindrops and due to water and wind. The higher the maximum water column, the better protected the material is against penetration by water.

For roof underlay, on the other hand, water columns of over 1500 mm are advisable, i.e. a functional membrane is essential.

In New Zealand, the "Resistance to water penetration" test in accordance with the AS/NZS 4201.4 standard, is also used for wall wraps.

"This was determined by exposing twelve test specimens to a 20 mm head of a 0.05 % methylene blue solution at a temperature of 23°C for 24 hours. The test area was approximately 45 cm². The test is considered a fail if any solution

passes through the specimen in a 24 hour period". Fleece materials with a very fine fibrous structure as well as other woven or knitted structures all pass this test. A monolithic, non-porous TEEE membrane is especially suitable, as it provides added protection against wood preservative due to its non-porous nature and its internal chemical structure. see Fig. 54. & 55.

Salts in wood preservative can damage the porous structure of the membrane. Wetting agents (tensides) in wood preservative, added to help the salts penetrate the wood, reduce the surface tension of water and make porous, woven and knitted structures more permeable to water, a bit like dish-washing up liquid. Monolithic TEEE membrane, which is naturally free of pores, is resistant to these effects.

5.3. Windtightness

In addition to the vapour permeability and watertightness, it is necessary to consider the windtightness. Poor windproofing can result in water penetrating the construction due to rain or blowing snow.

The external windtightness protects the construction from the effects of wind suction and wind pressure, which can be considerable in New Zealand. Air movements in the building envelope, for example due to wind, result in deterioration of the thermal insulation, both in the winter as well as in the summer, and should be prevented.

Wall wraps or roof underlays that use a membrane which is non-porous and diffusion-open provide ideal protection against wind, as they are windtight. This makes them superior to porous and microporous fabrics and woven structures. It is advantageous to use tapes to seal the overlaps and fittings, e.g. doors and windows.

5.4. Conclusion

- Wall wraps should have:
 - High diffusion permeability
 - High rain impermeability
 - High windtightness
- The higher the diffusion permeability, the better. Ideally, the diffusion resistance should be below 0.75 MNs/g. The higher the maximum water column, the better the protection provided against water that penetrates the cladding. It is good to have a water column greater than 1500 mm and to use membrane that is also suitable for use in roofs. pro clima SOLITEX EXTASANA (with TEEE membrane) meets these requirements (water column more than 10,000 mm).
- Windtightness provides added protection against energy loss and humidification as well as penetration by water from outside in the summer, while also providing better protection against summer condensation on the inside of the construction. It is best to use membrane that is windtight, which does not allow any air to be exchanged, unlike microporous membrane, fleece, and woven or knitted fabrics. pro clima SOLITEX EXTASANA meets these requirements. The TEEE membrane integrated between two layers of protective fleece is unique in its ability to fulfill the requirements for: High diffusion permeability, active diffusion transport, rain impermeability, windtightness.
- The ideal addition to complement any wall wrap is the intelligent moisture management membrane pro clima INTELLO, which is able to compensate even the negative effects of wall wraps and components with higher diffusion resistance.
- Active moisture transport offers a high protection against condensation on the surface and by this a high protection against mould.

Fig. 50, 51, 52.

Building in Ireland with different membranes. The poor airtightness shows different effects



clioma house ltd, Sligo, Ireland

Different products installed: Microporous membrane – Nonporous SOLITEX TEEE membrane



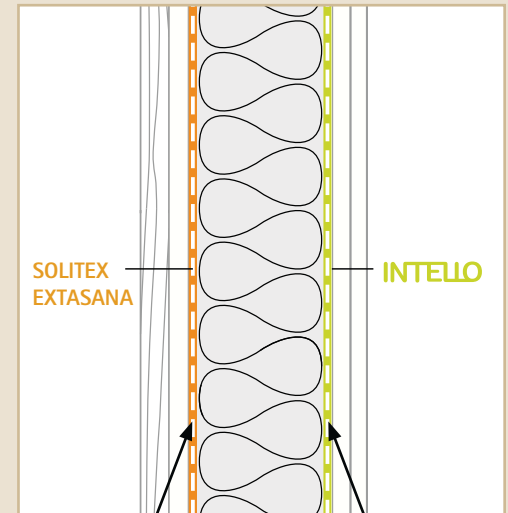
Microporous membrane – Passive diffusion transport: Wet – condensation



Nonporous SOLITEX TEEE membrane – Active diffusion transport: Dry – No condensation

Fig. 53.

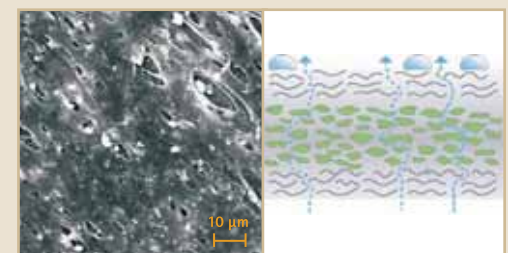
A well protected wall construction



- | | |
|----------------------------------------------------------------------------------------------------------------------------------------------------------------------------------------------------------------------------------------------------|---------------------------------------------------------------------------------------------------------------------------------------------------------------------------------------------------------------------------------------------------------------------------------------------------------------------------------------------------------------------|
| <p>Wall wrap on the outside</p> <ul style="list-style-type: none"> - Highly diffusion-open with active diffusion transport - Very rainproof and windtight - Maximum protection provided by airtight TEEE membrane | <p>Airtightness on the inside with intelligent moisture management</p> <ul style="list-style-type: none"> - Humidity-variable diffusion resistance - Very diffusion-inhibiting in the winter -> ideal protection against condensation forming - Diffusion-open in the summer -> ideal protection against summer condensation |
|----------------------------------------------------------------------------------------------------------------------------------------------------------------------------------------------------------------------------------------------------|---------------------------------------------------------------------------------------------------------------------------------------------------------------------------------------------------------------------------------------------------------------------------------------------------------------------------------------------------------------------|

Fig. 54.

Traditional micro porous membrane – low safety margin

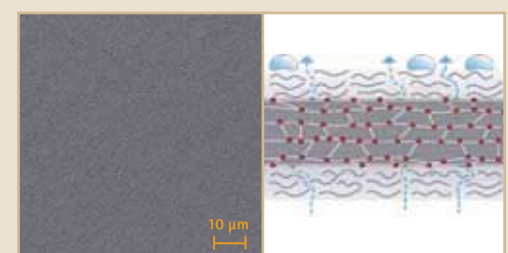


Microscopic detail of a porous membrane

Passive diffusion transport

Fig. 55.

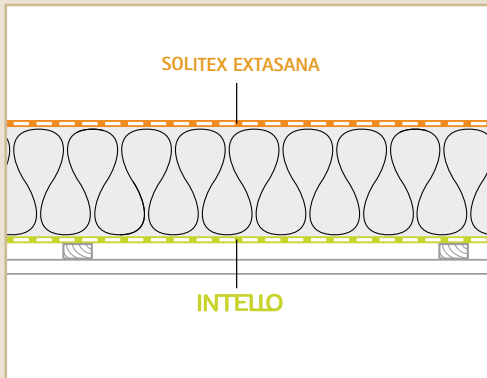
SOLITEX non porous membrane – optimum protection



Microscopic detail of a non porous membrane

Active diffusion transport

Fig. 56.
Protection for the insulation on the ceiling of the top floor



Advantages of covering the thermal insulation with wall wrap, e.g. pro clima SOLITEX products:

- Improved protection against the heat in the summer
- Protection against summer condensation under the insulation

NOTE:

Just like wall construction, ceiling structures also need to have an airtightness layer on the inside of the insulation.

The results of poor or lacking airtightness are:

- High heating costs due to heat loss
- Risk of structural damage and mould

The outer surface of the thermal insulation in the ceiling should be covered by a highly diffusion-permeable wall wrap or roof underlay such as SOLITEX EXTASANA or SOLITEX MENTO PLUS.

A high level of protection is afforded by an intelligent moisture management system.

NOTE:

To provide the construction with the best possible protection, roof underlay should have the following characteristics:

- Cover fleece on top and underneath: gives the web strength and provides mechanical protection to the membrane in the middle
- TEEE membrane: Non-porous, high thermal stability, impermeable to driving rain, high diffusion-permeability, active diffusion transport

6. Roofs

6.1. Thermal insulation and freedom from structural damage

To date, attic space has rarely been used as a living space in New Zealand. The thermal insulation is laid on the ceiling of the top floor in a pitched roof.

In the winter it would be ideal for vapour diffusion if the thermal insulation were to be laid open and uncovered. However this would then allow cold air to flow into the insulation, reducing its effectiveness.

In the summer, open insulation would have two disadvantages:

- Warm air that flows into the insulation in the summer would reduce the protection it provides from the heat. First the insulating material itself and then the living space below it would warm up.
- The current of warm air from outdoors would cool down on its way from outside into the building. Because cooler air is able to hold less moisture there would be a risk of water condensing on the cooler surfaces of the building material inside (summer condensation).

It is therefore beneficial for the thermal insulation laid above the top floor of the building to be covered with a layer of wall wrap that is very diffusion-open. An example is pro clima SOLITEX EXTASANA, which prevents air currents from blowing through it.

The same principles apply to ceiling constructions as to wall constructions: If there are air flows from inside the building the energy efficiency drops and the risk of structural damage rises.

Equally, it is essential to have an airtight layer and that an intelligent moisture management system is the ideal solution in terms of protection against structural damage.

6.2. Roof underlays

Roof underlays are installed under the roof cladding. They act as the second line of defence against rain. This protection is necessary if there are leaks in the roof cladding, which may be caused by design problems or due to the effects of the elements.

The roof underlay has to meet the following requirements:

- High mechanical strength, even in rain
- High resistance to nails being torn out by wind and storms
- Sufficient watertightness
- High vapour permeability
- High thermal stability
- High UV stability

Roof underlays with a three layer structure are beneficial in terms of protection against structural damage. Two layers of fleece, above and below, give the web strength and provide mechanical protection to the membrane in the middle. The membrane determines how waterproof it is and should ideally be diffusion-open.

Under the roof cladding the temperature can rise as high as 80°C in the summer, in the winter it can drop as low as 0°C, depending on the location. This extreme temperature fluctuations exert significant thermal stress on the roof underlay, in particular on the membrane. TEEE membrane, made of thermoplastic ether ester elastomer, has proven very successful (used e.g. in airbags of cars). This plastic has a melting point of about 200°C, which is twice that of polyethylene, and is thus characterised by extremely high thermal stability. This membrane is non-porous and diffusion-open. Moisture is actively transported along the molecular chains and is not transported by vapour convection flow, as it is in porous structures. This gives it a high dehumidification capacity and provides good protection against structural damage. Under the current *New Zealand Building Code* these synthetic products are outside E2/AS1 as the clause E2 in table 23 only refers to bitumen and fire-retardant paper based products.

Impermeable, diffusion-tight membrane on the outside can result in condensation forming in the winter, especially if there is no airtightness membrane on the inside.

To achieve good, long-term protection against structural damage and the elements when laying it, the roof underlay should fulfil at least the following minimum requirements:

- Diffusion-resistance less than 0.75 MNs/g
- Non-porous structure
- Watertight, water column greater than 150 mm
- Thermal stability greater than 90°C
- UV-stabilised for more than 2 months
- Weight over 120 g/m²
- Tear strength over 150 N/5 cm
- Nail tear resistance over 100 N

The weight is important to prevent the membrane from flapping in the wind under the roof cladding. This is especially important in New Zealand.

Rainwater has to be able to drain off. If the horizontal roof battens are right on the roofing underlay, the batten can act as a dam, resulting in ponding water, see Fig. 57. a). The nail then acts like a wick due to the capillary action on the nail shank, creating a localised leak in the membrane.

To ensure the roof underlay is rain-proof, it is necessary to at least use counter battening (battens along the rafters), see Fig. 57. b).

For roofs that require an especially watertight roof underlay, such as rooms in the attic, gently sloped roofs, roof cladding that is not watertight and very demanding environmental conditions due to high winds, rain and snow, nail sealing tape such as TESCON NAIDEC can be used.

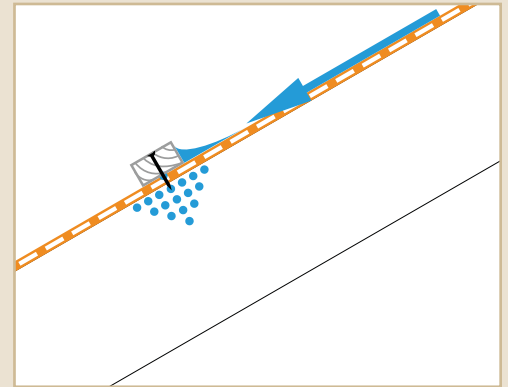
6.3. Skillion roofs

If attics in pitched roofs are used as living space the physical demands on them are similar to those for walls. It is beneficial to have a construction that is diffusion-open on the outside. Under the roof cladding, thermally insulated roof constructions need a diffusion-open and properly functioning sub-roof, to meet New Zealand's varying climatic demands.

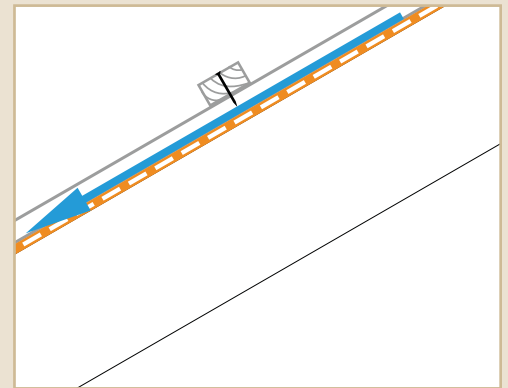
The ideal solution is a combination of intelligent moisture management on the inside and diffusion-open roof underlay such as SOLITEX MENTO PLUS on the outside. This provides maximum protection for the building envelope and guarantees a healthy living environment: pro clima INTELLO on the inside to allow the construction to dry out reliably, and pro clima SOLITEX MENTO PLUS on the outside with non-porous, diffusion-open and thermally stable membrane. They transport the moisture actively along the molecular chains and have high mechanical strength, which makes installation on the building site easier and provides a high level of protection to the system once the building is in use.

Impermeable bitumen roof sheeting is often used on the outside of buildings in New Zealand. As described above, this has a negative effect on the moisture characteristics. In the winter there is a risk of condensation forming on the underside of the bitumen underlay. It is therefore especially important to fit an intelligent moisture management system in these constructions to protect the roof from structural damage. This need is catered for by pro clima INTELLO, which compensates for the diffusion problem thanks to the humidity-variability of the membrane, regardless of which type of roof underlay is used - diffusion-open or not.

Fig. 57 a) & 57 b).
Roof battens and protection against rain

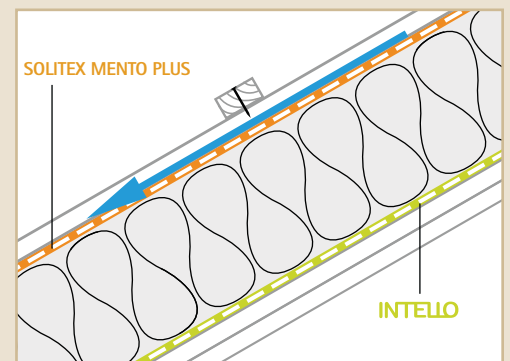


If roof battens are right on the roof underlay, the batten can act as a dam, resulting in ponding water that can then penetrate around the nails.



To ensure a watertight roof, at least counter battens should be used (battens along the rafters). Additional protection is provided by nail sealing tapes such as TESCON NAIDEC under the counter battens.

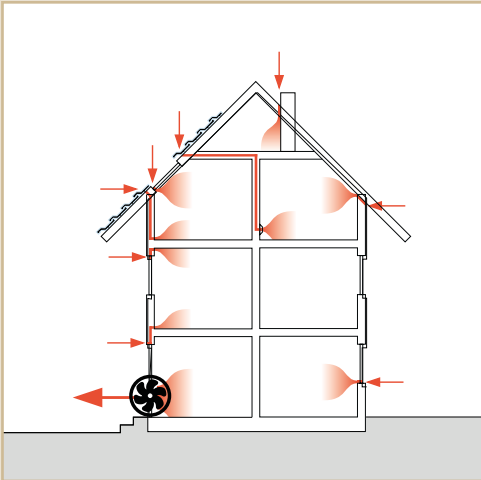
Fig. 58.
A well protected roof structure



If there are rooms immediately under pitched roofs, the physical demands are similar to those for walls. The requirements for a well protected roof construction are therefore also similar to those for walls:

- Intelligent moisture management using INTELLO on the inside
- Thermal insulation
- A well protected roof using SOLITEX MENTO PLUS on the outside

Fig. 59.
Schematic diagram of an airtightness test



A fan creates low pressure in the building. Where there are penetrates, air enters the building from outside. These defects can then be put right relatively effortlessly.

Fig. 60.
Airtightness verification



pro clima WINCON

7. Quality assurance: inspection and measurement of the airtightness of the building envelope

Inspection and measurement of the airtightness of the building envelope is common practice almost worldwide and is the state of the art in many countries. This measurement aims to identify weak points in the airtightness layer and assist in repairing defects in order to prevent structural damage due to vapour convection.

A fan is fitted to an opening (exterior door or window) and a partial vacuum (of 50 Pa) is created in the building by sucking air out. It is then possible to find leaks in the building envelope either simply using your senses, e.g. by feeling the draught on the back of your hand, or to make them visible using smoke (smoke tubes or a smoke generator). If leaks are found, they can then be put right using suitable remedies, see Fig. 59.

The volume of air required to create the partial vacuum varies, depending on the number and size of the leaks. By comparing the volume of air required with the volume of the building it is possible to determine how airtight the building is.

The parameter used to describe the airtightness is called the n_{50} value. This value describes the ratio between the the volume of air moved by the fan and the volume of the building at a test pressure of 50 Pa. The n_{50} value is calculated from this volume flow by dividing the volume flow by the total volume of air in the building:

$$n_{50} = \frac{\text{Air flow volume of the fan}}{\text{Total air volume in the building}}$$

To determine the n_{50} value an measurement at a higher pressure is also carried out, as well as at a partial vacuum. Each of these measurements has a different pressure profile. The average of these two volume flow rates is then calculated.

The required n_{50} values for Central Europe are:

- Building without a ventilation system, legal requirement: less than 3 air changes per hour
- Building with a ventilation system, legal requirement: less than 1.5 air changes per hour
- Passive houses, voluntary standard: less than 0.6 air changes per hour

Often airtightness is only tested after construction work has been completed. If the legal requirements are not met, a new building may then need to be renovated at great expense, as this means that the entire inner lining first needs to be removed before the airtightness can be put right and then re-tested. After thus if the re-test was successful, the inner lining can be replaced.


For this reason it is increasingly common in Europe to perform a simple and practical airtightness test before final assembly of the inner lining. In contrast to the measurement of the n_{50} value, no actual value is measured. Instead, the effective airtightness of the building envelope is tested. This can either be done using a "Blower Door" or the cheaper WINCON, a practical unit with a higher volume flow rate, but without any complex measuring equipment.

Using the WINCON it is possible to test the airtightness layer once the work has been completed to check whether it really is airtight, thus helping to avoid any nasty surprises when a Blower Door test is subsequently performed.

ACCEPTANCE TEST RECORD

Performing an airtightness test is always worthwhile. Training increases the reliability of testing performance, creates customer confidence and documents the quality of the work done.

7.1. Building leakage test



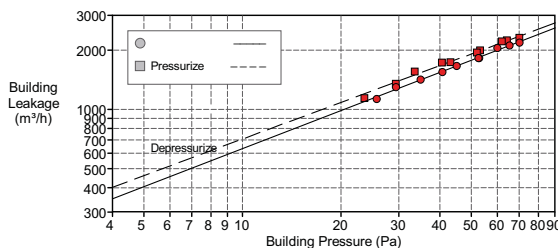
BUILDING LEAKAGE TEST

Pro Clima NZ Limited
PO Box 925
CBD
Wellington, 6041
Phone: 04 385 4161
Fax: 04 385 4162

Date of Test: 13.12.2010 Technician: Thomas van Raamsdonk
 Test File: 13.12.2010 double glazing with gas filling

Customer: [REDACTED] Building Address: House with double glazing with gas filling, Auckland

	Depressurization	Pressurization	Average
Test Results at 50 Pascals:			
V50: Airflow (m ³ /h)	1778 (+/- 0.5 %)	1912 (+/- 0.7 %)	1845
n50: Air Changes per Hour (1/h)	6.48	6.97	6.73
w50: m ³ /(h·m ² Floor Area)	15.55	16.73	16.14
q50: m ³ /(h·m ² Surface Area)	5.18	5.57	5.38
Leakage Areas:			
Canadian EqLA @ 10 Pa (cm ²)	706.2 (+/- 3.0 %)	789.8 (+/- 4.0 %)	748.0
cm ² /m ² Surface Area	2.06	2.30	2.18
LBL ELA @ 4 Pa (cm ²)	378.3 (+/- 4.7 %)	432.7 (+/- 6.2 %)	405.5
cm ² /m ² Surface Area	1.10	1.26	1.18
Building Leakage Curve:			
Air Flow Coefficient (Cenv)	145.2 (+/- 7.2 %)	171.4 (+/- 9.5 %)	
Air Leakage Coefficient (CL)	144.4 (+/- 7.2 %)	170.8 (+/- 9.5 %)	
Exponent (n)	0.642 (+/- 0.018)	0.617 (+/- 0.024)	
Correlation Coefficient	0.99677	0.99396	
Test Standard:	EN 13829		Regulation complied with: EN13829
Type of Test Method:	A		
Equipment:	Model 4 (230V) Minneapolis Blower Door, S/N CE2962		
Inside Temperature:	23 °C	Volume:	274 m ³
Outside Temperature:	25 °C	Surface Area:	343 m ²
Barometric Pressure:	101325 Pa	Floor Area:	114 m ²
Wind Class:	1 Light Air	Uncertainty of	
Building Wind Exposure:	Highly Exposed Building	Building Dimensions:	5 %
Type of Heating:	None	Year of Construction:	2010
Type of Air Conditioning:	None		
Type of Ventilation:	None		



Comments

Blower Door installed in laundry door.
 Extraction fans in bathroom and ensuite connected to the outside.
 Manhole 600 mm x 600 mm.
 No range hood or extraction fan in kitchen.
 Timber piles on concrete footings.
 20 mm particle board flooring.

Data Points: Depressurization:

Nominal Building Pressure (Pa)	Fan Pressure (Pa)	Nominal Flow (m ³ /h)	Temperature Adjusted Flow (m ³ /h)	% Error	Fan Configuration
0.5	n/a				
-69.4	65.8	2172	2184	-1.1	Ring A
-64.6	61.3	2098	2110	-0.1	Ring A
-59.2	58.2	2043	2055	2.9	Ring A
-52.1	46.0	1816	1827	-0.8	Ring A
-51.8	45.5	1810	1821	-0.8	Ring A
-44.2	38.0	1654	1664	0.1	Ring A
-40.0	32.8	1538	1547	-0.8	Ring A
-34.2	309.8	1411	1420	0.4	Ring B
-28.6	257.8	1288	1296	2.6	Ring B
-24.9	195.2	1122	1129	-2.7	Ring B
1.0	n/a				

Test 1 Baseline (Pa): p01- = -1.0 p01+ = 1.3 p02- = -0.6 p02+ = 1.4

Data Points: Pressurization:

Nominal Building Pressure (Pa)	Fan Pressure (Pa)	Nominal Flow (m ³ /h)	Temperature Adjusted Flow (m ³ /h)	% Error	Fan Configuration
-0.6					
70.1	74.6	2310	2306	-2.6	Ring A
64.3	70.6	2249	2244	-0.0	Ring A
62.1	68.4	2214	2209	0.6	Ring A
53.2	55.7	1999	1995	-0.3	Ring A
52.0	52.6	1944	1940	-1.6	Ring A
43.1	41.9	1736	1733	-1.5	Ring A
40.7	41.8	1734	1730	1.9	Ring A
33.6	33.7	1558	1555	2.9	Ring A
29.4	25.2	1350	1348	-3.3	Ring A
23.6	202.8	1143	1141	-6.4	Ring B
0.6	n/a				

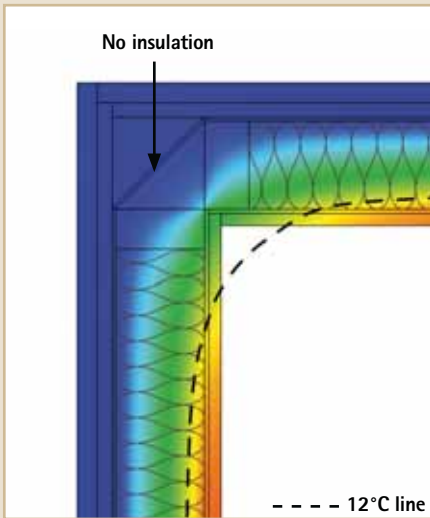
Test 1 Baseline (Pa): p01- = -2.5 p01+ = 1.4 p02- = -0.2 p02+ = 0.8

Figs. 61, 62, 63, 64.
Blower Door test

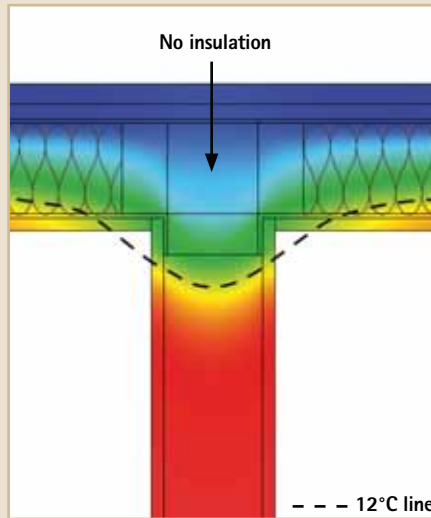


Fig. 65 a) & Fig. 65 b)

Schematic diagram of a thermal bridge caused by geometry (a corner) and by material (missing insulation)



Uninsulated corners cause thermal bridges.



Uninsulated joints of integrated internal walls cause thermal bridges.

Figs. 66, 67, 68.



Figs. 69, 70, 71.



Figs. 72, 73, 74.



8. Thermal bridges

Thermal bridges are spots in a construction where the insulating layer is interrupted or otherwise imperfect. A distinction is made between thermal bridges caused by geometry (geometric thermal bridge) and those caused by materials (structural thermal bridge).

8.1. Geometric thermal bridges

Thermal bridges caused by geometry can be found, for example, in corners and junctions of building elements. In these situations the outside surface area is greater than the inner surface area allowing the outer surface to radiate more energy outward.

The corners of buildings and fittings integrated in the external building envelope pose a particular risk of forming thermal bridges if the joints are inadequately insulated, or not insulated at all, see Figs. 65. a) & b).

In New Zealand, the frames of buildings with masonry cladding are often constructed in such a way that there are two studs diametrically opposite each other at the corners of the building. There is thus no stud at the actual corner, creating an uninsulated void, a thermal bridge. This void is closed off by the wall wrap on the outside and by the two studs on the inside. It is thus only possible to insulate the outer corner before the wall wrap is fitted. However, this is not usually done during construction, so the corners remain uninsulated, see Figs. 66. – 68.

Building envelopes with wooden cladding have a stud added in the corner of the building. This ameliorates the thermal bridge.

The same situation occurs at the joints of internal walls, where the stud for the internal wall is often facing inwards, right beside two posts of the exterior wall. Here again, the void between the two studs is closed off by the wall wrap and the stud for the interior wall and it is thus only possible to insulate it before the wall wrap is fitted, see Figs. 69. – 71.

The corner of the building cannot be insulated by the person who installs the thermal insulation if the wall wrap has already been fitted.

The same also applies to joints between exterior walls. Once the wall wrap has been fitted it is impossible to add more insulation from the inside.

Thermal bridges on this scale result in significant cooling of the surfaces of the inner lining, thus causing higher humidity and potentially condensation, and thus mould growth on the surfaces. Mould is able to grow even if there is just elevated humidity, not only if it is wet.

An uninterrupted layer of thermal insulation can also be prevented by fittings in the wall.

If there are fittings in the layer of the wall where the insulation is, it is very difficult to ensure adequate thermal insulation in the compartments, see **Figs. 72. – 74.**

This is another place where thermal bridges occur, resulting in cooling of the internal surfaces and thus creating a risk of mould.

8.2. Structural thermal bridges

Structural thermal bridges due to the material are caused by the use of materials that have high thermal conductivity, e.g. metal, and in particular steel beams.

Steel is often used as a static element in wooden constructions to absorb high single or line loads, if required by the structure.

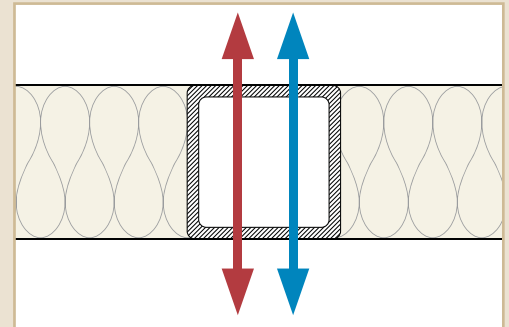
Steel components act as structural thermal bridges in wooden structures as well as in steel structures, such as steel frame buildings. In such cases it is advisable to add a layer of thermal insulation to at least one side of the metal framework.

Heat is conducted out of a building by steel very fast in the winter, so steel components are always the coldest spots in any structure. This can reduce the surface temperature on the inside significantly, causing condensation to form either on the surface or within the structure.

A layer of thermal insulation should be put on at least one side (preferably on the outside) of steel components to reduce the effect of structural thermal bridges. Ideally, steel components should be insulated on all four sides, but this is not always practically possible.

In addition to posing a risk of mould and structural damage, thermal bridges also result in heat loss, resulting in higher heating costs and thus in higher CO₂ emissions.

Fig. 75.
Schematic diagram of structural thermal bridges caused by materials



A steel support conducts the heat out of the building faster than the insulated compartment.

Fig. 76.



Fig. 77.



Insulate steel beams on at least one side, preferably on the outside

Fig. 78.



Insulate steel structures on at least one side, preferably on the outside

Fig. 79.
Bitumen membrane outdoors



Moisture trap:
Do not lay bitumen membrane up the outside of the wall.

Fig. 80.
WBP outdoors



External stiffening with wood-based panels: Only with intelligent moisture management

Fig. 81.
Sheet metal outdoors



External stiffening with sheet metal:
Only with intelligent moisture management.

Figs. 79, 80, 81.
Diffusion-inhibiting layers of building material on the outside such as bitumen membrane, WBP or sheet metal, call for intelligent moisture management on the inside.

9. Notes on planning and construction

9.1. Wall constructions and general information

In New Zealand, wall constructions generally have a drainage cavity as specified in Department of Building and Housing guidelines [32] to allow any condensation that forms in the cavity to drain away. Building envelopes which allow condensation to form in the winter should always be avoided. The ideal solution is condensation-free constructions, i.e. building envelopes in which no condensation is formed, either within the construction or in the drainage cavity. To provide long-term protection against structural damage and mould, particular attention should be paid to back-diffusion capacity in the summer and to preventing summer condensation.

The investigations of the building physics using real-life meteorological data for New Zealand show that the freedom from structural damage is very high for constructions that use the intelligent moisture management membrane pro clima INTELLO, with its very high humidity-variable diffusion resistance that is effective in every climate zone.

Building envelopes need to be airtight to protect them from structural damage and mould, ensure high energy efficiency and prevent unforeseen heat loss. The pro clima INTELLO membrane is ideal for this.

External wall wrap should have a diffusion resistance of less than 0.75 MNs/g.

The higher the diffusion resistance on the outside, the more condensation can form in the winter and the greater the risk of structural damage, and thus the lower the potential freedom from structural damage. If constructions have a diffusion-inhibiting barrier on the outside, an airtightness membrane with intelligent moisture management is essential on the inside, as the drainage cavity is then on the outside of the membrane or boards. In addition to this, the airtightness also reduces the amount of humidity from indoor air, thus reducing the risk of structural damage.

The intelligent airtightness membrane made by pro clima, with its humidity-variable diffusion resistance, is capable of controlling and compensating for the diffusion flow so effectively that it is even possible to use metal cladding on the outside if there is also a drainage cavity.

Layers of building material that are in direct contact with the framework on the outside, such as wall wraps or plywood should have a diffusion resistance of no more than 30 MNs/g, when installed in conjunction with pro clima INTELLO. If material with a higher diffusion resistance are used on the outside, the constructions should be evaluated and approved by the pro clima New Zealand technical team. The simulations calculated using WUFI show that pro clima INTELLO is even capable of compensating for impermeable layers on the outside, although it is nevertheless advisable to perform a separate assessment of the building materials to ensure the highest possible potential freedom from structural damage. To achieve a high degree of fault tolerance and freedom from structural damage it is generally preferable to opt for constructions that are diffusion-open to the outside.

In locations with high outdoor humidity we recommend the use of wall lining membrane to reduce moisture absorption.

Bitumen membrane, used to protect wooden structures from rising damp, should not be laid up the wall, on the one hand due to their impermeability, and on the other because condensation and driving rain would run directly into the bottom plate. It is sufficient to separate the wooden structure from the foundation slab with a strip of bitumen membrane under the bottom plate for protection against rising damp, see Fig. 79.

In steel frame buildings the external metal bracing elements act as vapour barriers that are essential for structural reasons, but that need to be controlled with regard to their diffusion characteristics, see Fig. 81.

9.2. Roof structures

Roofs should be as diffusion-open as possible to maximise the potential freedom from structural damage. The ideal solution is a SOLITEX membrane with TEEE film, in particular due to its high thermal stability, its vapour permeability, watertightness and insensitivity to wood preservative. Note: that synthetic roof underlays are currently, as per September 2011, an Alternative Solution under E2/AS1.

Impermeable roof underlays act as vapour barriers on the outer (cold) side. Although it is possible to solve the diffusion problem with the intelligent moisture management membrane INTELLO, as it permits moisture compensation inwards, constructions that are open to diffusion on the outside have a higher potential freedom from structural damage.

9.3. Internal cladding

To exploit the high degree of protection provided by intelligent moisture management, it is important that moisture is able to dry out into the building without any blockage. It is therefore advisable to avoid diffusion-inhibiting cladding on the inside. Wood-based materials (e.g. plywood) fitted over the airtightness membrane on the indoor side reduce the ability for moisture to dry out inwards and also pose the risk of summer condensation on the back of the boards, facing away from the room, see Fig. 82.

It is beneficial to use diffusion-open materials such as plasterboard.

9.4. Permanently damp rooms

In residential buildings humidity-variable airtightness membrane can be used in all rooms that are used for normal purposes, even in rooms that are temporarily subjected to increased humidity levels such as bedrooms, bathrooms or the kitchen.

Buildings and rooms with permanently high levels of humidity such as swimming pools, garden centres or large-scale catering establishments, etc., call for specific consideration of their physical demands and may only

be fitted with variable airtightness membrane within very tight thresholds. Consultation with pro clima New Zealand during the design and planning stage is essential for such constructions.

9.5. Moisture caused by residents and moisture in new buildings

9.5.1. Damp rooms: the 60/10 rule

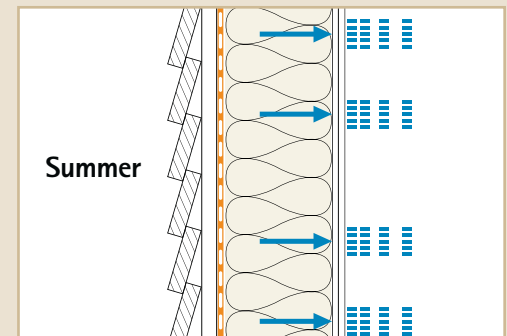
Case studies have shown that humidity-variable airtightness membrane needs to meet certain requirements with regard to diffusion resistance. During normal use of residential buildings the diffusion resistance should never be less than 10 MNs/g to ensure that the building does not suffer structural damage. Here the 60/10 rule applies. This means that a humidity-variable airtightness membrane needs to have a diffusion resistance of no less than 10 MNs/g at an ambient average humidity of 60%.

In wet and humid rooms in residential buildings the relative humidity can be as high as 70% at a temperature of 20°C. INTELLO humidity-variable airtightness membrane, which has a diffusion resistance of 20 MNs/g at an average humidity of 60%, provides ideal protection, even for these rooms, by adhering to the 60/10 rule (at 70% humidity of the air in the room and 50% humidity in the insulating layer = 60% average humidity). This means the building envelopes of residential buildings are adequately protected against moisture from the air and mould resulting from such moisture, see Fig. 83, page 42

9.5.2. Increased humidity during the building phase: the 70/7.5 rule

The requirements for humidity-variable airtightness membrane during construction are similar, except that here it is necessary to protect the construction from the elevated moisture levels caused by construction. This moisture stress is only temporary, as the residual moisture needs to be removed from the building by means of ventilation

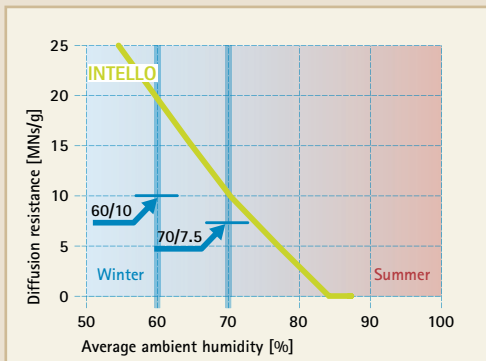
Fig. 82. Externally impermeable structure in the summer



For constructions that are diffusion-inhibiting on the outside it is advisable to avoid diffusion-inhibiting material on the inside.

Intelligent moisture management using INTELLO, however, ensures a high potential freedom from structural damage.

Fig. 83.
The 60/10 & 70/7.5 rules



Adhering to the 60/10 and 70/7.5 rules ensures a high potential freedom from structural damage for thermal insulation in new buildings and during construction.

Diffusion resistance at 60% RH: 10 MNs/g
INTELLO = 20 MNs/g => High level of protection

Diffusion resistance at 70% RH: 7.5 MNs/g
INTELLO = 10 MNs/g => High level of protection

(or using a dryer) after the time that it takes for the mineral-based building materials to dry out (e.g. the floor slab). In these conditions, humidity-variable airtightness membrane needs to adhere to the 70/7.5 rule. This means it needs to have a diffusion resistance of 7.5 MNs/g at an ambient average humidity of 70% to protect the construction from the moisture caused by construction.

pro clima INTELLO fulfils the 70/7.5 rule, thus providing a high degree of protection during construction. At an average relative humidity of 70% (90% humidity of the air in the room and 50% humidity in the insulation = 70% average humidity at a room temperature of 20°C) INTELLO has a diffusion resistance of 10 MNs/g, see Fig. 83.

If the construction sequence is well planned and executed, humidity-variable airtightness membrane provides good protection against mould, even during construction.

If the moisture caused during construction is not removed from the building by ventilation or using a dryer after the mineral-based building materials have dried this may, in principle, result in dampness being retained. It is therefore advisable to provide good ventilation to remove the moisture as fast as possible. Dryers are useful in addition to natural ventilation.

9.6. Proper control of ventilation systems

Ventilation systems should always operate at an underpressure if it is colder on the outside to avoid warm, humid air (which may cause mould) from penetrating the inner lining from inside the building and condensing there.

Conversely, ventilation systems should operate at an overpressure if it is outside warmer than inside to allow the (cooler) indoor air to pick up additional moisture on its way through the structure and thus contribute to drying the construction.

9.7. The service cavity

The so-called service cavity has proven itself to be ideal in ensuring uninterrupted and simple provision of channels for electrical installations within the construction. This is where an additional layer of battens is affixed for electrical installations after assembly and connection of the intelligent moisture management system to the framing.

If the inner lining is not used as a bracing element (for example, if bracing is provided by bracing straps, suitable WBP or fibre cement boards) it is preferable to install the battens horizontally so that the electrical installations can be installed between them.

The inner lining panel is then fixed to these battens. The advantages of this alternative are the ease of laying and fixing the electrical installations to the framework and the high level of protection provided to the building envelope because the thermal insulation is not interrupted and the airtightness membrane is left intact.

9.8. Foam insulation

Foam insulation (i.e. PUR or PS) usually has a high diffusion resistance and low moisture transport capacity. This means that foam insulation poses a serious barrier to back-diffusion. Foam insulation in physically demanding or critical constructions if an intelligent moisture management is used should therefore be avoided. Fibrous insulation is ideal for construction in the New Zealand climate.

An exterior construction detail (i.e. wall or roof) that has a higher diffusion resistance towards the outside from inside has a potential condensation risk. A high safety margin against structural damage with INTELLO is only guaranteed if the temperature on the outer side of the insulation can be higher than on the inside to allow for back diffusion.

Ideal are dark colours for the roof covering like untreated concrete roof tiles as these have a shortwave radiation absorptivity higher than 0.65. Bright colours, white or even reflective

colours do not lead to warming of the construction from the outside and consequently back diffusion may not occur.

9.9. The right time for installing the airtightness membrane

When installing the insulation and airtightness membrane, it is important that the insulating material is covered by a layer of airtightness membrane as soon as it has been put in place if this is done in the winter. Without the airtightness membrane the humidity from the room can enter the construction unhindered, then cool (especially at night) in the insulation and cause condensation to form in the insulation.

As described above, constructions with an installation level are recommended, as this allows the airtightness membrane to be left intact and simplifies installation. It takes much more effort to install and connect the airtightness membrane in building components without a service cavity level because a lot of penetrations are needed, which mean additional work.

The insulating material and airtightness membrane should be laid step by step. The airtightness membrane is connected to the adjacent building components immediately after having been laid. This procedure avoids condensation forming in the region of the joints.

9.10. Dry building materials when installing thermal insulation

The timber used for the framing should be dry when the thermal insulation is installed and when the airtightness layer is put in place, as should the thermal insulating material.

9.11. Recycling and eco-friendliness

To permit easy recycling, the intelligent moisture management membrane INTELLO and INTELLO PLUS are 100% polyolefins - the special membrane is made of polyethylene copolymer, the fleece and the fabric are made of polypropylene.

10. Installation

10.1. Installation of the INTELLO membrane

Install INTELLO with the printed side (the side with the plastic film on) facing in towards the room. The physical properties are not dependent on the orientation, so it is not necessary to remove and replace it if it is accidentally laid with the printed side facing the framing.

The TESCON VANA tape should always be pressed on firmly. It is best to stick it onto the side with the plastic film on.

10.2. Installation direction

pro clima INTELLO can be installed horizontally along or at right angles to the framing-structure.

If it is installed vertically, the overlaps of membrane must meet on the structure. If installed at right angles to the framing, the maximum space permitted between the studs is 1000 mm.

10.3. Recommended pro clima system components for bonding and sealing

All pro clima adhesive tapes are suitable for bonding the overlaps between sheets of membrane. Ideally, the material properties of the tape should be the same as those of the airtightness membrane, especially if installing it at right angles to the framing. TESCON VANA is thus the best choice for use with INTELLO. The best choice for joints to windows and doors as well as in corners is TESCON PROFIL adhesive tape, due to its high nail tear strength and the split release paper.

ORCON joint adhesive is ideal for bonding to adjacent parts of the construction such as concrete floors tiles and plastered gable walls.

If pipes or cables penetrate the airtightness layer, they too must be securely sealed. KAFLEX cable grommets are self-adhesive.

Remove the release paper, push over the cable and stick on. ROFLEX pipe grommets are affixed using TESCON VANA. Press firmly to secure the adhesive tape. KAFLEX post can be used to

Fig. 85.
Installation



Fig. 86.
Taping overlaps



Fig. 87.
Floor joint



Fig. 88.
Beam joint



Fig. 89.
KAFLEX cable grommet



Fig. 90.
ROFLEX pipe grommet fixed with
TESCON VANA



Fig. 91.
KAFLEX post



Fig. 92.
Installation box



provide an airtight seal to an installed cable that is already connected.

The pro clima INSTAABOX can be used for airtight installation of electrical installations in outside walls, for instance for electrical sockets or light switches. The cables can then be fed out through the soft material with self-sealing exit points from the INSTAABOX, which provides space for flush boxes etc., thus avoiding structural damage due to convection.

Further recommendations can be found in the pro clima INTELLO installation brochure.

10.4. Connecting airtightness membrane to the floor

At the base of the wall the airtightness membrane needs to be connected to the floor. pro clima INTELLO can be bonded with a continuous bead of ORCON joint adhesive to create a well sealed, airtight system that provides excellent protection for the constructions.

10.5. Dimensional stability

The high performance airtightness membrane INTELLO does not shrink. INTELLO can be installed taut, without sagging, and combines high elasticity with high tear strength.

10.6. Mechanical strength

INTELLO and INTELLO PLUS both have high nail tear strength, meaning that they are well protected against formation and propagation of tears where they are stapled.

10.7. Translucent structure

The high performance airtightness membrane INTELLO is translucent (allows light to shine through), meaning that materials directly behind the membrane can be seen. INTELLO is not completely transparent, so that the edges of the sheets are easily visible, an advantage when attaching it to adjacent parts of the building such as ridge purlins, roof windows and chimneys as well as when taping for the building envelope.

10.8. Installation of cables and pipes in exterior walls

It is common practice in New Zealand to install cables and pipes within the insulation layer of the exterior walls. This not only compromises the insulation but also makes it more complex to install the airtightness layer. A more efficient method is to allow for an internal service cavity. After fitting the insulation within the framing layer, the INTELLO membrane is fixed towards the inside of the framing. The next step is installing the battens on top of the INTELLO to create the service cavity to allow for cables and pipes. This also forms a perfect sub-structure for the fixing of inner lining (i.e. plasterboard) as per suppliers recommendations.

The advantages of the service cavity are that there is no need to drill holes into the framing and no cables or pipes are penetrating the airtightness layer. In addition the service cavity prevents insulation creating pressure points against the plasterboard.

For bracing options please follow the recommendations of manufacturers of bracing elements on the outside (plywood or fibre cement boards), internal bracing elements (plasterboard) or engineers providing project specific solutions.

11. CONCLUSION AND SUMMARY

- Constructions fitted with pro clima INTELLO offer an optimised performance to keep permanently dry and protected from structural damage and mould thanks to their intelligent moisture management. Even in the event of unforeseen or practically unavoidable moisture stress, the construction has a high potential freedom from structural damage thanks to the high drying capacity due to the humidity-variable diffusion resistance.
 - The high performance airtightness membrane INTELLO offers an exceptionally high variability of diffusion resistance that is effective in any climate and thus provides unparalleled protection for thermally insulated walls and roofs in the New Zealand climate.
 - Additional peace of mind is granted by the six year pro clima system performance guarantee.
 - "The higher the drying capability of a construction, the greater the unforeseen moisture stress that it can tolerate and still remain free of mould and structural damage."
 - This ensures ideal protection against structural damage and mould and a healthy living environment
- ... for ourselves and for our children.

Further information about application and construction can be found in the pro clima planning documentation.

Contact the pro clima technical team:

Pro Clima NZ Limited
Phone: 04 385 4161
Fax: 04 385 4162
e-mail: welcome@proclima.co.nz

References

- [1] www.suite101.com/content/worlds-cleanest-air-a53508
- [2] www.teara.govt.nz/en/atmosphere/5
- [3] www.asthmafoundation.org.nz/in_new_zealand.php
- [4] www.asthmanz.co.nz/files/PDF-files/burdenkey.pdf
- [5] www.asthmafoundation.org.nz/_6.php
- [6] Moschandreas DJ. Exposure to pollutants and daily time budgets of people. Bull N Y Acad Med 1981;57:845-59.
- [7] Digital Comprehensive Summaries of Uppsala Dissertations 159 from the Faculty of Medicine Asthma and Respiratory Symptoms in Nordic Countries
MARÍA I. GUNNBJÖRNSDÓTTIR
ACTA UNIVERSITATIS UPSALIENSIS UPPSALA 2006
- [8] Brasche S, Bischof W. Daily time spent indoors in German homes. Baseline data for the assessment of indoor exposures of German occupants. Int J Hyg Environ Health 2005;208:247-53.
- [9] Butler S, Williams M, Tukuitonga C, Paterson J. Problems with damp and cold housing among Pacific families in New Zealand. N Z Med J 2003;116:U494.
- [10] <http://thorax.bmj.com/content/61/3/221.full.pdf>
- [11] Fallbeispiele - Bauschäden durch mangelhafte Luftdichtheit Lamers, Reinhard;aus: 10. BlowerDoor-Symposium des E.U.Z. BlowerDoor-Technik und Anwendungsmöglichkeiten, Haltbarkeit von Verklebungen, Zertifizierungen, Luftdichtheit und (Bau-)Recht am 17. Juni 2005 in Hannover-Laatzten mit begleitender Fachausstellung, Selbstverlag 2005, Abb.S.34-35
Fraunhofer Institute of Building Physics Stuttgart
- [12] Gallup J, Kozak P, Cummins L, Gillman S. Indoor mold spore exposure: characteristics of 127 homes in southern California with endogenous mold problems. Experientia Suppl 1987;51:139-42.
- [13] Brunekreef B, Dockery DW, Speizer FE, Ware JH, Spengler JD, Ferris BG. Home dampness and respiratory morbidity in children. Am Rev Respir Dis 1989;140:1363-7.
- [14] Dales RE, Burnett R, Zwanenburg H. Adverse health effects among adults exposed to home dampness and molds. Am Rev Respir Dis 1991;143:505-9.
- [15] Andriessen JW, Brunekreef B, Roemer W. Home dampness and respiratory health status in European children. Clin Exp Allergy 1998;28:1191-200.
- [16] Lee YL, Hsiue TR, Lee CH, Su HJ, Guo YL. Home exposures, parental atopy, and occurrence of asthma symptoms in adulthood in southern Taiwan. Chest 2006;129:300-8.
- [17] Peat JK, Dickerson J, Li J. Effects of damp and mould in the home on respiratory health: a review of the literature. Allergy 1998;53:120-8.
- [18] Bornehag CG, Blomquist G, Gyntelberg F, Jarvholm B, Malmberg P, Nordvall L, et al. Dampness in buildings and health. Nordic interdisciplinary review of the scientific evidence on associations between exposure to "dampness" in buildings and health effects (NORDDAMP). Indoor Air 2001;11:72-86.
- [19] Zureik M, Neukirch C, Leynaert B, Liard R, Bousquet J, Neukirch F. Sensitisation to airborne moulds and severity of asthma: cross sectional study from European Community respiratory health survey. BMJ 2002;325:411-4.
- [20] whqlibdoc.who.int/euro/ehs/EURO_EHS_16.pdf
- [21] www.energywise.govt.nz/
- [22] Do damp and mould matter? Health impacts of leaky homes
Philippa Howden-Chapman
Julie Bennett
Rob Siebers
Steele Roberts Publishers Aotearoa New Zealand
ISBN 978-1-877448-89-8
- [23] How to survive a Leaky Home
Yvonne van Dongen
A Hodda Moa by Hachette New Zealand
ISBN 978-186971-200-6
- [24] <http://www.eeca.govt.nz/node/3107>
- [25] Deutsche Bauzeitung; Heft 12/89 pp 1639
- [26] NZ Building Performance Ltd. Blower Door Test for HNZC May/June 2010
- [27] http://www.greenbeing.co.nz/news/11_COMPARING-THE-THERMAL-PERFORMANCE-OF-STEEL-STUD-WALLS-WITH-TIMBER-WALL-STUDS.html
- [28] DIN EN ISO 13 788, Wärme- und feuchtetechnisches Verhalten von Bauteilen und Bauelementen - Raumseitige Oberflächentemperatur zur Vermeidung kritischer Oberflächenfeuchte und Tauwasserbildung im Bauteilinneren - Berechnungsverfahren
- [29] WUFI 4.1 pro (Wärme- und Feuchte instationär); computer programme for calculating the coupled 2-dimensional heat and moisture transport in building materials; Fraunhofer Institute for Building Physics; Further information available on www.wufi-pro.com
- [30] Fraunhofer Institute for Building Physics
- [31] TenWolde, A. et al.: "Air pressures in wood frame walls, proceedings thermal VII." Ashrae Publication Atlanta, 1999
- [32] Department of Building and Housing. Construction cavities for wall claddings

www.proclima.co.nz

Pro Clima NZ Limited

PO Box 925
CBD
Wellington 6140
Phone 04 385 4161
Fax 04 385 4162
e-mail welcome@proclima.co.nz

MOLL bauökologische Produkte GmbH

pro clima
Rheintalstraße 35 - 43
68723 Schwetzingen
Germany



The information provided here is based on practical experience and the current state of knowledge. We reserve the right to make changes to the recommendations given or to make alterations due to technical developments and associated improvements in the quality of our products. We would be happy to inform you of the current technical state of the art at the time you use our products.

Last updated: 2011/09