

A3114 Pro Clima Wall Timber Framing Detail

Connection strip 140mm wall section, Direct fixing

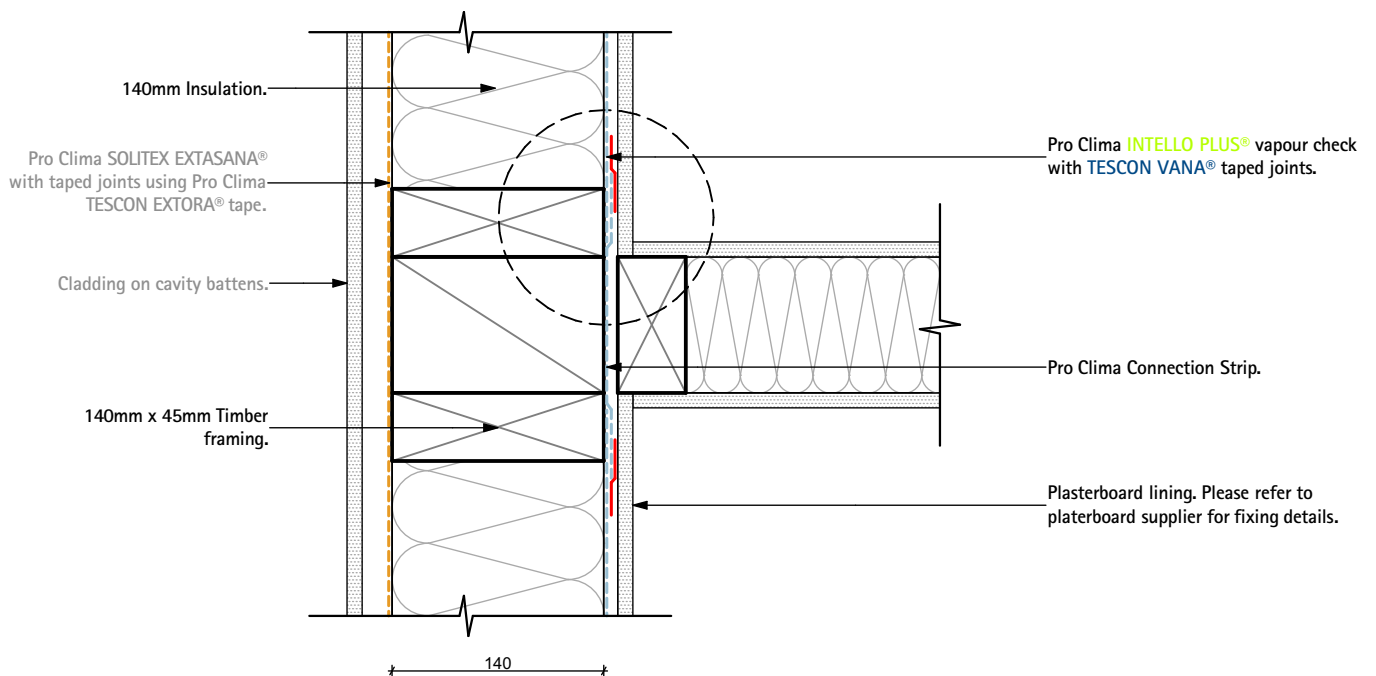
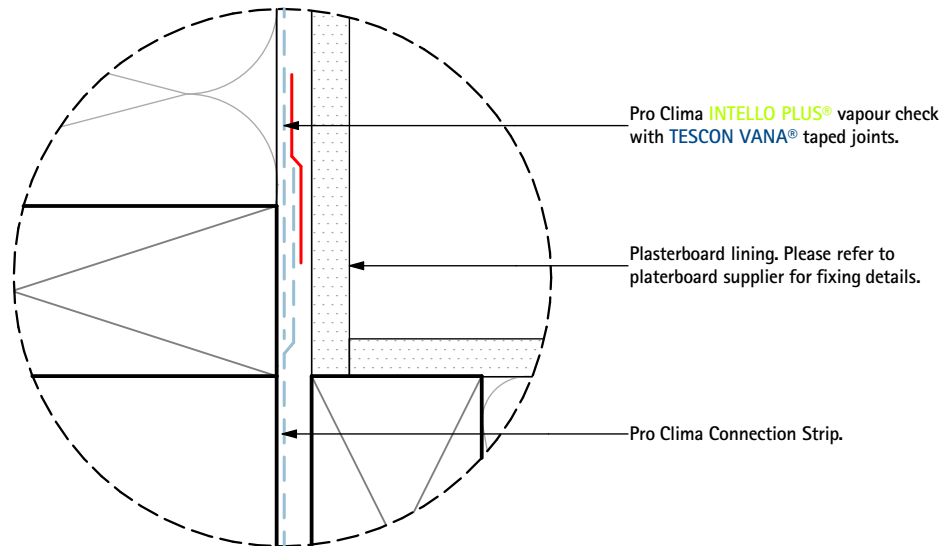

Pro Clima NZ Limited

Freephone: 0800 PRO CLIMA (776 254)
PO Box 925 CBD

Phone: 04 589 8460
Fax: 04 589 8461

Wellington 6140

Email: support@proclima.co.nz
Web: www.proclima.co.nz

Title:

Wall Timber Framing Detail

Scale: 1:2, 1:5
Revision: D
Issued: 06-03-2019

Detail
Number:

A3114

© This drawing is the property of pro clima and must not be copied without permission. This drawing is a Guideline only. Thermal and hygrothermal performance should match specific design, materials and climate requirements. These can be confirmed by hygrothermal analysis using software eg WUFI.