

A3113 Pro Clima Wall Timber Framing Detail

Connection strip 90mm wall section with 45mm service cavity

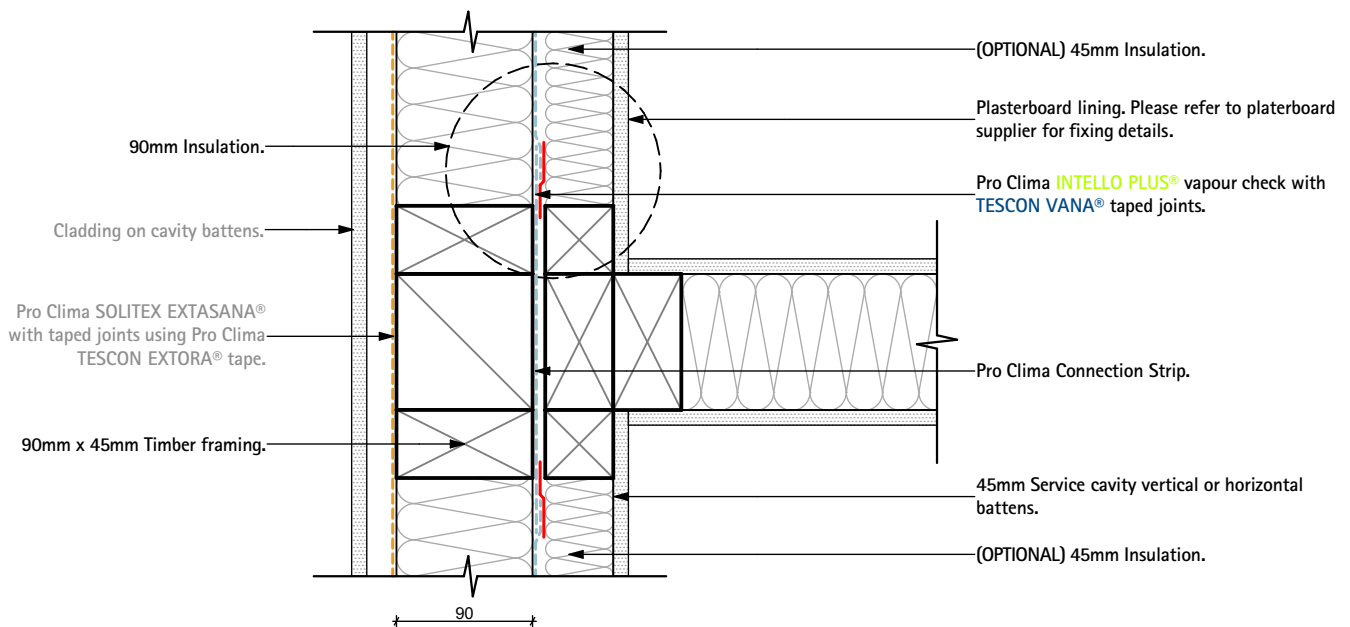

NOTE: Connection Strip must be installed during framing stage.

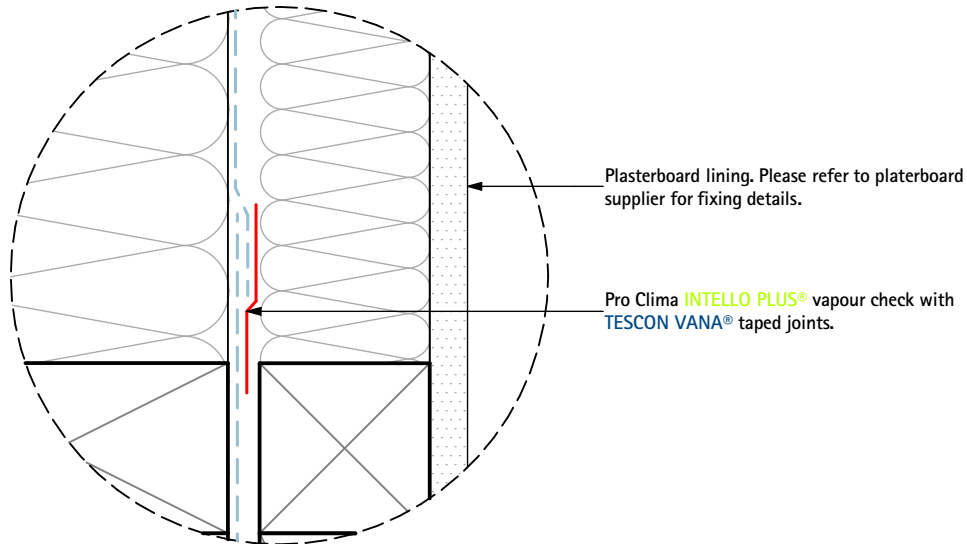

Pro Clima NZ Limited

Freephone: 0800 PRO CLIMA (776 254)
PO Box 925 CBD

Phone: 04 589 8460
Fax: 04 589 8461

Wellington 6140

Email: support@proclima.co.nz
Web: www.proclima.co.nz

Title:

Wall Timber Framing Detail

Scale: 1:5, 1:2
Revision: D
Issued: 06-03-2019

Detail
Number:

A3113

© This drawing is the property of pro clima and must not be copied without permission. This drawing is a Guideline only. Thermal and hygrothermal performance should match specific design, materials and climate requirements. These can be confirmed by hygrothermal analysis using software eg WUFI.