

PRO-JOIST SPECIFICATION

PRODUCT DESCRIPTION

The Pro-Joist saddle flashing is a moulded , one piece flashing for waterproofing the junction where a timber joist or rafter cantilevers through from inside the building to the outside. The Pro-Joist is manufactured from a single piece of UV stabilised polypropylene.

The Pro-Joist is designed to flash dressed timber 47mm or 94mm thick and up to 250mm deep. The flashing has indication marks to show where the excess is to be cut away when fitting joists smaller than 250mm deep.

It is the role of the saddle flashing as a secondary line of defence to control any moisture and redirect it to the exterior without contacting the internal framing timbers.

FEATURES AND BENEFITS

- Pro-Joist has no laps or joins.
- BRANZ appraised for use in all wind zones up to and including very high.
- Superior and cost effective saddle flashing.
- Tough and durable yet flexible for ease of installation.
- Pro-Joist is not effected by glues, silicones or timber treatments.
- Pro-Joist can be easily cut with a knife or saw to fit any depth joist up to 250mmm deep.
- Available to fit 47mm or 94mm wide timber.
- The flanges on the Pro-Joist are designed to spring back against the inside surface of the cladding to ensure a superior weather seal.
- Pro-Joist can be painted to match colour requirements.
- Will not crack or corrode.
- Pro-Joist will not split when nailed through even in cold conditions.
- Meets the requirements of NZBC Clause E2.3.2

SHELF LIFE

Pro-Joist has an indefinite shelf life, however care should be taken to ensure the product is not exposed to chemicals or extreme conditions that may affect its integrity.

DURABILITY

The Pro-Joist saddle flashing is expected to have a serviceable life compatible with that of the cladding as long as it is not exposed to the UV for more than 30 days and the cladding is maintained in accordance with the manufacturer's specifications.

INSTALLATION

The Pro-Joist saddle flashing can be installed without a cavity batten if required. When cavity battens are used encircle the joist or rafter with the cavity batten then fit the Pro-Joist saddle flashing.

- Measure the cantilevered timber depth. Locate the relevant indication mark on the Pro-Joist and cut the Pro-Joist to required size.
- Sit the Pro-Joist back in position and mark the outer edge of the flashing on the timber.
- Remove the Pro-Joist and apply a continuous bead of Holdfast BlackJack sealant 20mm inside the mark.
- Spread the fins of the Pro-Joist and fit into place.
- Hold in position by driving a galvanised clout through each side of the Pro-Joist and into the timber approximately 15mm from the front edge and halfway down the fins of the flashing.
- Before installing the cladding ensure the weather seal edge on the Pro-Joist is folded back allowing it to naturally spring up against the back of the cladding once it is installed.
- After the cladding is installed cut treated timber scribes to conceal the Pro-Joist or alternatively paint with an adhesive primer and two coats of exterior paint.

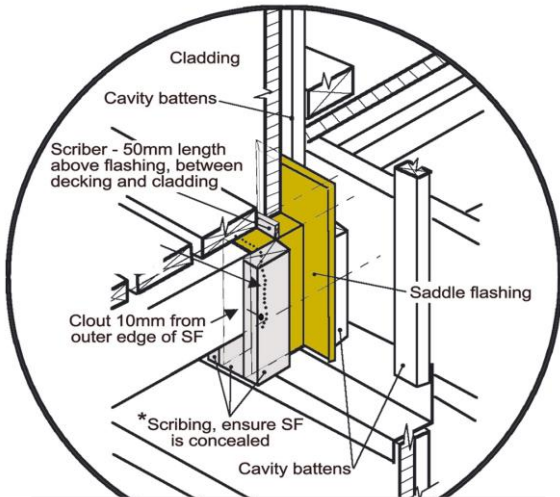

IMPORTANT

*Once the EvaDry Saddle Flashing (SF) has been fitted and the cladding installed, attach scribing as shown in the diagram to completely conceal each flashing from ultra violet rays. Alternatively use waterborne smooth surface function at its optimal level.